

Ta

TM223 engine

*CYLINDER HEAD	Fig. 1
*CYLINDER HEAD COVER	Fig. 2
*INLET MANIFOLD	Fig. 3
*EXHAUST MANIFOLD	Fig. 4
*CYLINDER BLOCK	Fig. 5
*BEARING/UNDER SIZE	Fig. 6
*OIL PAN	Fig. 7
*REAR PLATE	Fig. 8
*TIMING GEAR CASE	Fig. 9
*HANGER	Fig. 10
*VALVE	Fig. 11
*CAM SHAFT	Fig. 12
*PISTON	Fig. 13
*PISTON/OVER SIZE	Fig. 14
*CRANK SHAFT	Fig. 15
*OIL PUMP	Fig. 16
*WATER PUMP	Fig. 17
*COOLING FAN	Fig. 18
*INJECTION NOZZLE	Fig. 19
*INJECTION PUMP	Fig. 20
*FUEL PIPE	Fig. 21
*ELECTRIC(1)	Fig. 22
*ELECTRIC(2)	Fig. 23
*6215-300-036-00	Fig. 24
*6215-600-103-10	Fig. 25
*6281-100-005-10	Fig. 26
*6281-200-005-00	Fig. 27

FIG. 1 CYLINDER HEAD

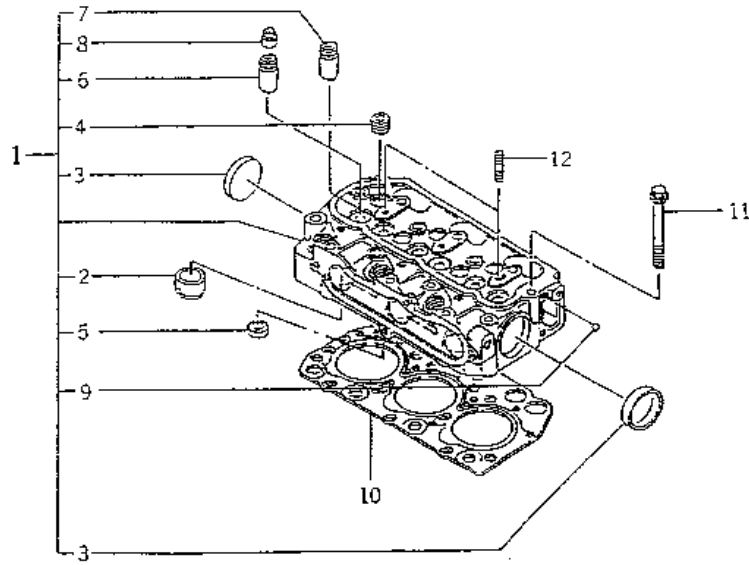

KEY	Part Code	Description	S P C	Type of Model						I T C	C O L	G R P	Remarks
				E311 2B07									
1	6211-110-057-00	CYLINDERHEAD ASSY	*	1									
2	6211-150-021-00	HOTPLUG ASSY	*	3									
3	6911-129-006-00	CAP, SEALING	*	2									
4	6209-605-004-10	PLUG/PT1/2	*	5									
5	6211-715-002-00	SEAT, VALVE	*	3									
6	6211-721-001-00	BULBE GUIDE	*	3									
7	6211-721-002-00	GUIDE, VALVE	*	3									
8	6212-569-002-00	SEAL, OIL	*	6									
9	V682-200-000-60	BALL	*	1									
10	6211-141-029-10	GASKET/CYLINDERHEAD	*	1									
11	6209-000-003-00	BOLT/M10X1.25X82	*	14									
12	6909-830-212-00	STUD, HEAD COVER	*	2									

FIG. 2 CYLINDER HEAD COVER

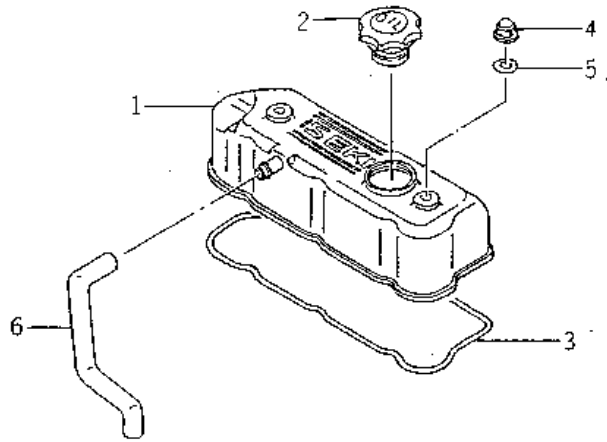

KEY	Part Code	Description	S P C	Type of Model						I T C	C O L	G R P	Remarks
				E311 2B07									
1	6211-170-004-10	COVER,CYLINDER HEAD	*	1									
2	6211-751-001-10	CAP,OIL FILLER	*	1									
3	6211-173-003-00	SEAL,CYL.HEAD COVER	*	1									
4	6209-490-002-00	NUT,CAP	*	2									
5	6909-572-008-00	PACKING	*	2									
6	6209-360-027-10	HOSE/RUBBER	*	1									

FIG. 3 INLET MANIFOLD

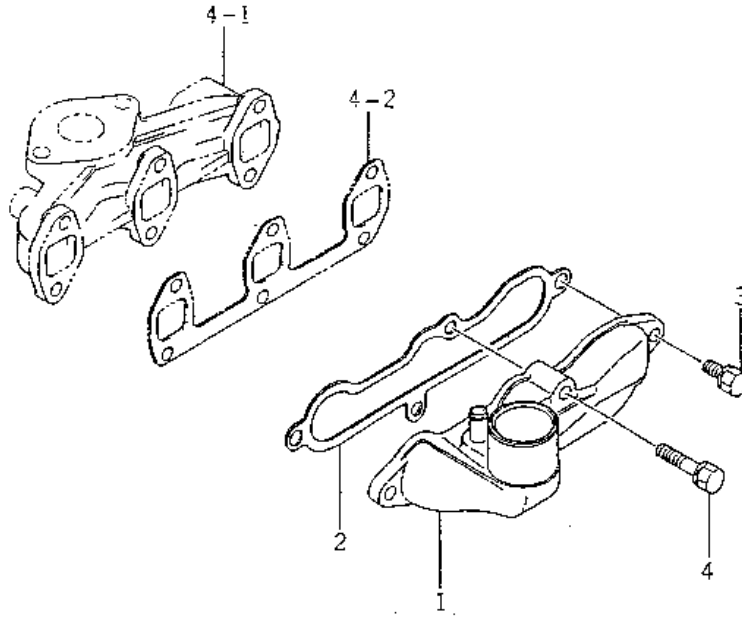

KEY	Part Code	Description	S P C	Type of Model						I T C	C O L	G R P	Remarks
				E311 2B07									
1	6214-111-011-20	MANIFOLD(INLET) ASSY	*	1									
2	6214-115-001-20	GASKET,INLET MANIFOL	*	1									
3	V211-560-802-00	BOLT/M8X20	*	3									
4	6901-910-840-00	BOLT	*	1									

FIG. 4 EXHAUST MANIFOLD

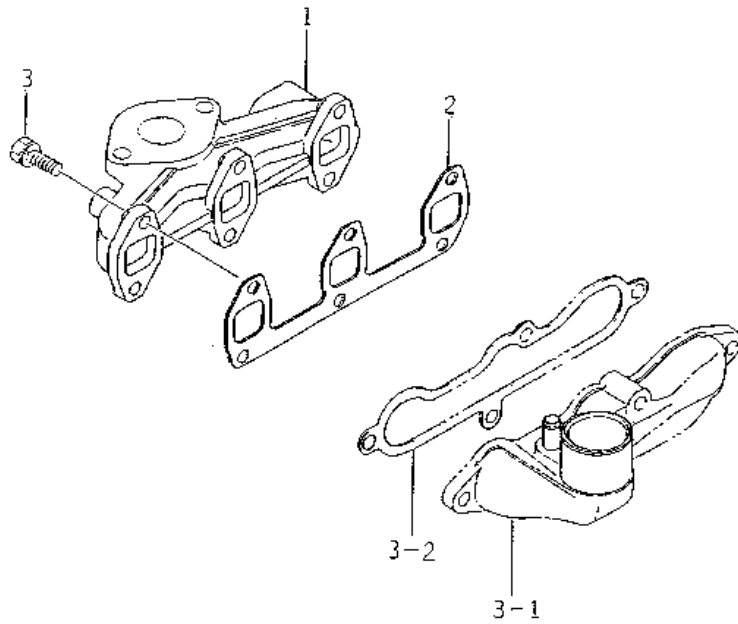

KEY	Part Code	Description	S P C	Type of Model						I T C	C O L	G R P	Remarks
				E311 2B07									
1	6214-141-010-10	MANIFOLD,EXH	*	1									
2	6214-145-001-30	GASKET,EXH.MANIFOLD	*	1									
3	V211-560-802-50	BOLT,SEMS/M8X25 7T	*	6									

FIG. 5 CYLINDER BLOCK

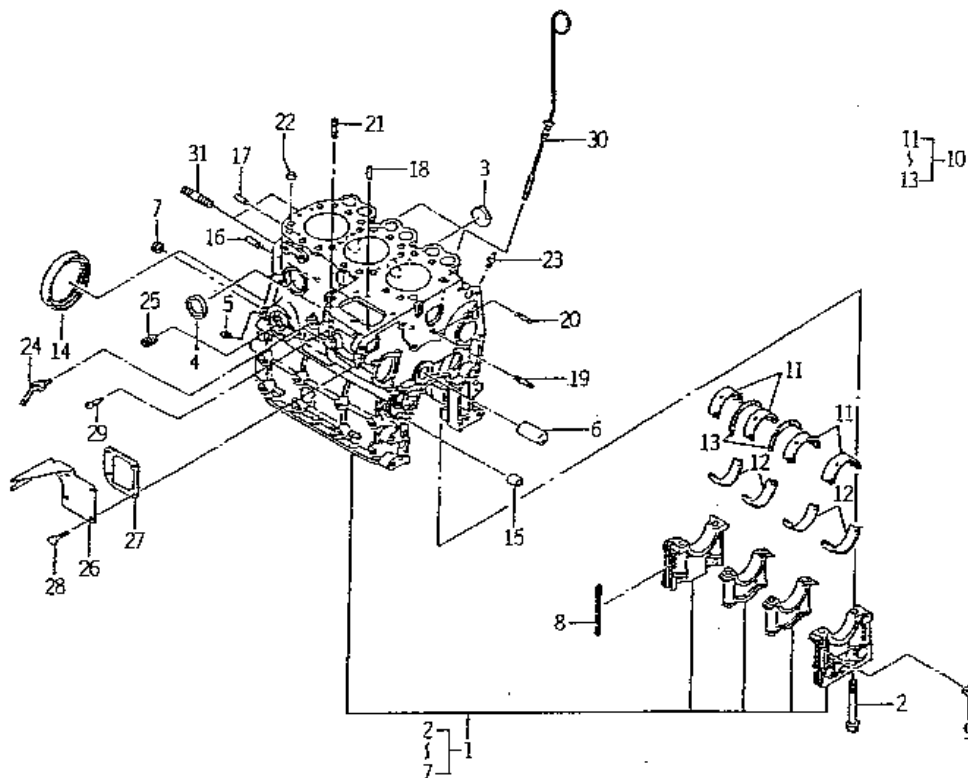

KEY	Part Code	Description	S P C	Type of Model					I T C	C O L	G R P	Remarks
				E311 2B07								
1	6211-210-037-20	CYLINDERBLOCK ASSY	*	1								
2	6209-000-004-10	BOLT	*	8								
3	6209-610-001-00	CAP,SEALING	*	2								
4	6911-219-195-00	CAP,SEALING	*	4								
5	6509-605-019-10	PLUG	*	3								
6	6212-531-005-10	PIN/IDLEGEAR	*	1								
7	6911-129-083-00	CAP,SEALING	*	2								
8	6211-258-001-00	SEAL,BEARING CAP	*	4								
9	6211-258-002-00	SEAL,BEARING CAP/7	*	2								
10	6211-510-001-00	METAL,CRANK SET	*	1								
11	6211-511-003-00	BEARING/CRANK/UPPER	*	4								
12	6211-511-004-00	BEARING/CRANK/LOWER	*	4								
13	6211-599-001-10	BEARING,THRUST CRANK	*	2								
14	6209-625-001-00	SEAL,OIL	*	1								
15	6209-749-001-20	PIN/TUBE	*	2								
16	6908-160-816-00	PIN	*	1								
17	V523-100-802-40	PIN	*	1								
18	6209-740-005-00	PIN	*	2								
19	6904-110-840-00	STUD/M8X40	*	1								
20	6904-110-818-00	STUD	*	1								
21	6904-110-822-00	STUD	*	2								
22	6294-453-002-00	DOWEL	*	2								
23	6909-902-299-00	NIPPLE	*	1								
24	6213-721-007-00	PIPE/WATERDRAIN	*	1								
25	6213-319-001-00	CONNECTOR,OIL FILTER	*	1								
26	6211-291-016-00	COVER/INJECTIONPUMP	*	1								
27	6211-292-001-20	GASKET/COVER	*	1								
28	6901-910-614-00	BOLT	*	4								
29	6215-549-013-00	PIN	*	1								
30	6211-760-012-20	LEVELGAGE	*	1								

FIG. 6 BEARING/UNDER SIZE (OPTION)

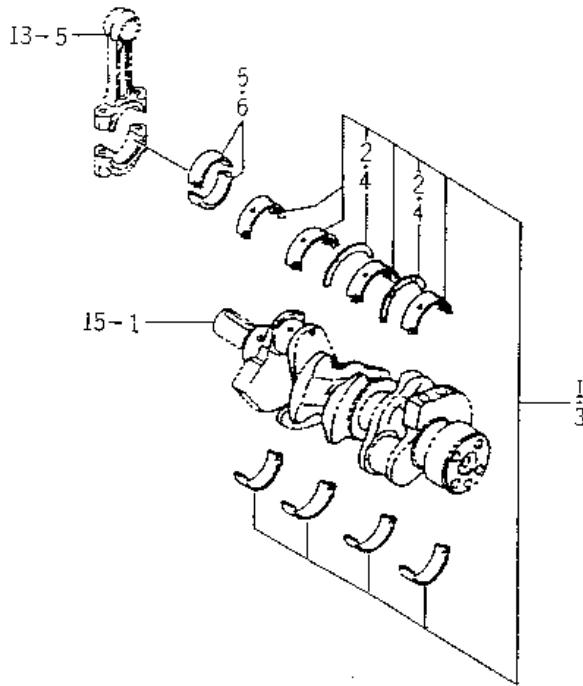

KEY	Part Code	Description	S P C	Type of Model						I T C	C O L	G R P	Remarks
				E311 2B07									
1	6211-540-001-00	METAL,CRANK SET	T	1								050	
2	6211-599-001-10	BEARING,THRUST CRANK	T	2									
3	6211-560-001-00	METAL,CRANK SET	T	1								100	
4	6211-599-001-10	BEARING,THRUST CRANK	T	2									
5	6212-264-006-00	BEARING/CONN ROD/UN	T	6								050	
6	6212-266-006-00	BEARING/CONN ROD/UN	T	6								100	

FIG. 7 OIL PAN

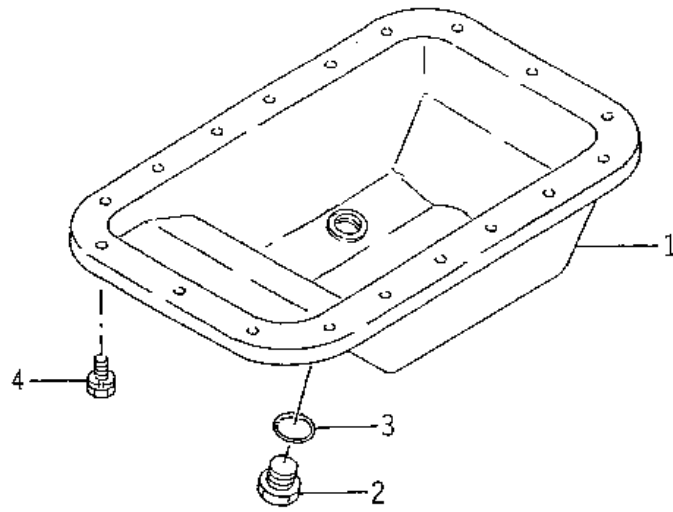

KEY	Part Code	Description	S P C	Type of Model					I T C	C O L	G R P	Remarks
				E311 2B07								
1	6211-361-010-10	PAN,OIL COMP	*	1								
2	3625-301-002-00	PLUG(M14X15)	*	1								
3	V720-102-401-80	O-RING/P18	*	1								
4	6901-910-612-00	BOLT,SEMS/M6X12	*	18								

FIG. 8 REAR PLATE

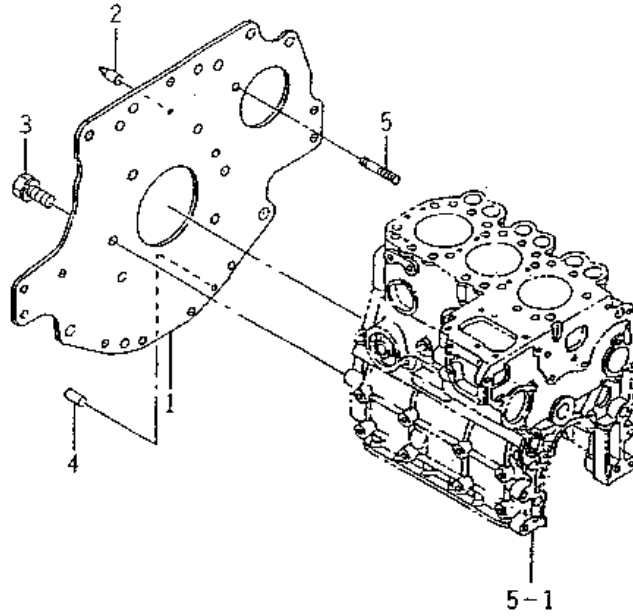

KEY	Part Code	Description	S P C	Type of Model						I T C	C O L	G R P	Remarks
				E311 2B07									
1	6211-341-032-00	PLATE/REAR	*	1									
2	6211-342-002-10	POINTER	*	1									
3	6901-911-020-00	BOLT,SEMS/M10X20	*	6									
4	6908-160-816-00	PIN	*	1									
5	6209-300-004-00	STUD	*	1									

FIG. 9 TIMING GEAR CASE

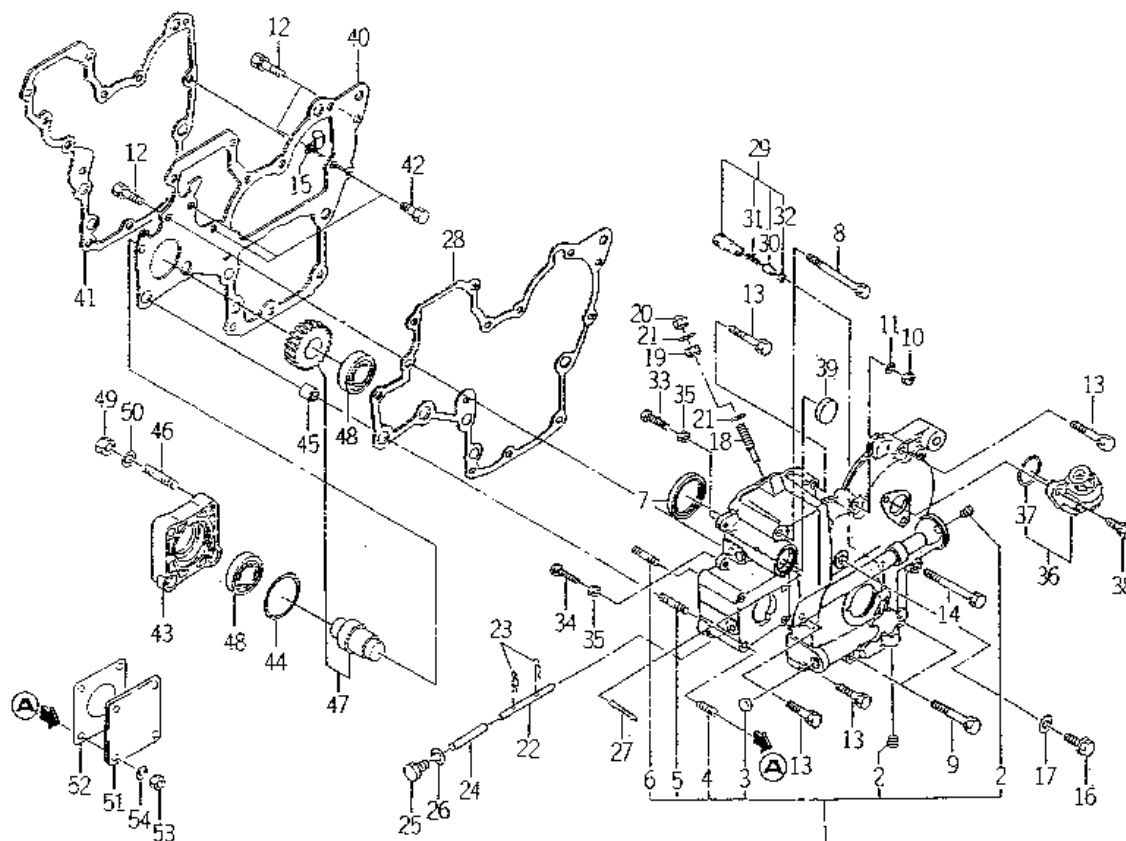

KEY	Part Code	Description	S P C	Type of Model					I T C	C O L	G R P	Remarks
				E311 2B07								
1	6211-310-012-20	GEARCASE ASSY	*	1								
2	6509-605-019-10	PLUG	*	2								
3	6209-610-002-10	CUP/SEALING/16	*	1								
4	6904-110-822-00	STUD	*	4								
5	6904-110-855-00	STUD	*	2								
6	6904-110-850-00	STUD	*	1								
7	6209-625-002-00	SEAL,OIL	*	1								
8	6209-030-005-00	BOLT/M8X85	*	1								
9	6509-000-084-00	BOLT/L=55	*	2								
10	6909-110-508-00	NUT/M8	*	1								
11	6909-150-508-00	WASHER	*	1								
12	V211-560-802-00	BOLT/M8X20	*	3								
13	6901-910-845-00	BOLT,SEMS/M8X45	*	5								
14	6209-030-006-00	BOLT/M8X75	*	1								
15	1425-621-004-00	CLAMP,HARNESS	*	2								
16	6209-046-001-00	BOLT/M8X30	*	1								
17	6209-500-003-00	WASHER/08X14X01	*	1								
18	6215-546-003-00	STOPPER/FULLLOAD	*	1								
19	6209-409-001-00	NUT/M8	*	1								
20	V341-120-008-00	NUT,CAP/M 8	*	1								
21	6209-920-002-00	PACKING	*	2								
22	6215-542-004-20	PIN/ARM	*	1								
23	P117-303-003-00	PIN/SNAP	*	2								
24	6215-542-005-00	PIN	*	1								
25	6909-202-308-00	PLUG	*	1								
26	6209-500-003-00	WASHER/08X14X01	*	1								
27	6209-740-001-00	PIN,GROOVE	*	1								
28	6211-312-003-20	GASKET/GEARCASE	*	1								
29	6213-160-002-10	VALVE/RELIEF ASSY	*	1								
30	6213-161-001-10	PISTON/VALVE/RELIEF	*	1								

FIG. 9 TIMING GEAR CASE

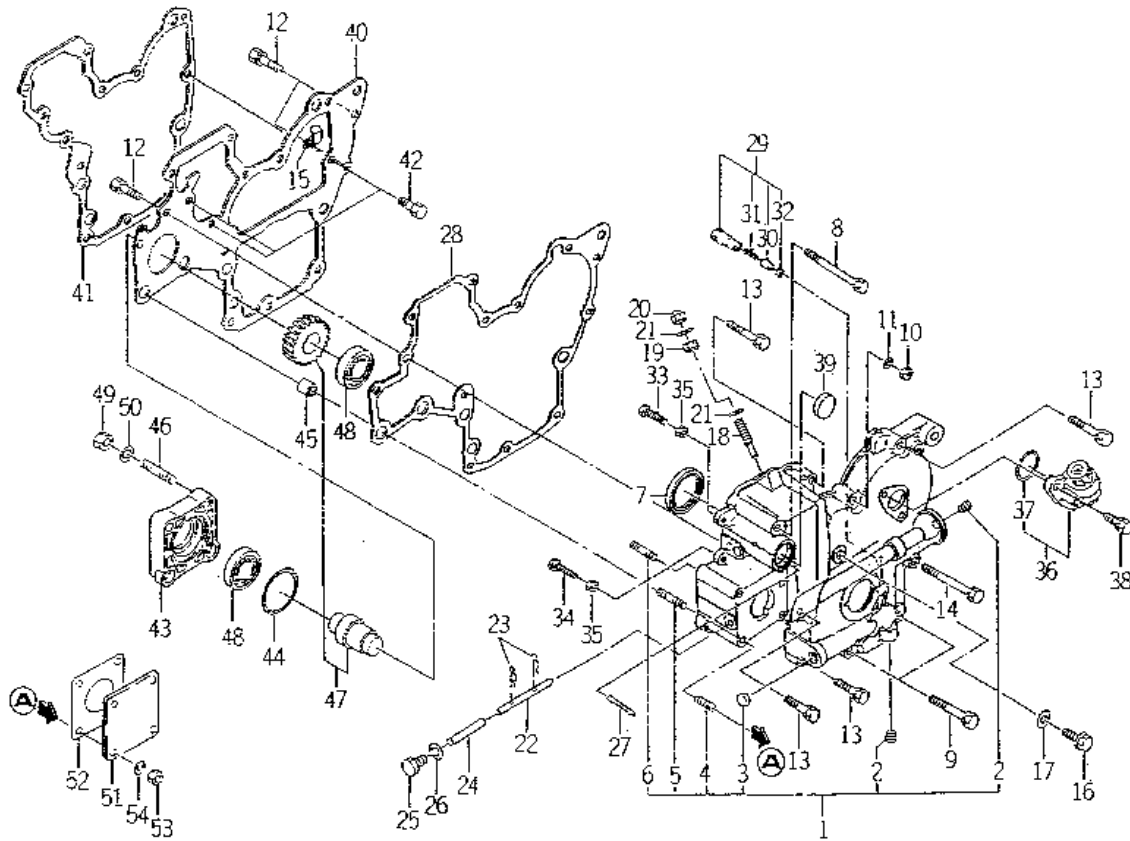

KEY	Part Code	Description	S P C	Type of Model						I T C	C O L	G R P	Remarks
				E311 2B07									
31	6213-164-001-00	SPRING/RELIEF VALVE	*	1									
32	V705-140-012-00	RING,SNAP/12 C	*	1									
33	6209-050-001-00	BOLT/M6	*	1									
34	6209-050-002-00	BOLT/M6	*	1									
35	6909-110-406-00	NUT	*	2									
36	6219-310-003-20	DRIVE/TACHOMETE ASSY	*	1									
37	V723-102-002-40	RING/O	*	1									
38	6901-910-616-00	BOLT,SEMS/M6X16	*	2									
39	3625-540-004-00	CAP,BLANK/30	*	1									
40	6211-311-007-20	PLATE,FRONT	*	1									
41	6211-312-004-20	GASKET/PLATE	*	1									
42	6902-050-816-00	BOLT	*	3									
43	6211-319-003-00	SPACER	*	1									
44	V723-102-005-00	O-RING 1A S50	*	1									
45	6209-749-001-20	PIN/TUBE	*	2									
46	6904-110-822-00	STUD	*	1									
47	6212-530-005-10	SHAFT/HYDRAULIC ASSY	*	1									
48	V600-110-600-50	BEARING,RB/6005	*	2									
49	6909-110-408-00	NUT/M8	*	4									
50	6909-150-508-00	WASHER	*	4									
51	6511-321-083-00	COVER	*	1									
52	6211-322-002-00	GASKET/COVER	*	1									
53	6909-110-408-00	NUT/M8	*	4									
54	6909-150-508-00	WASHER	*	4									

ω

FIG. 10 HANGER

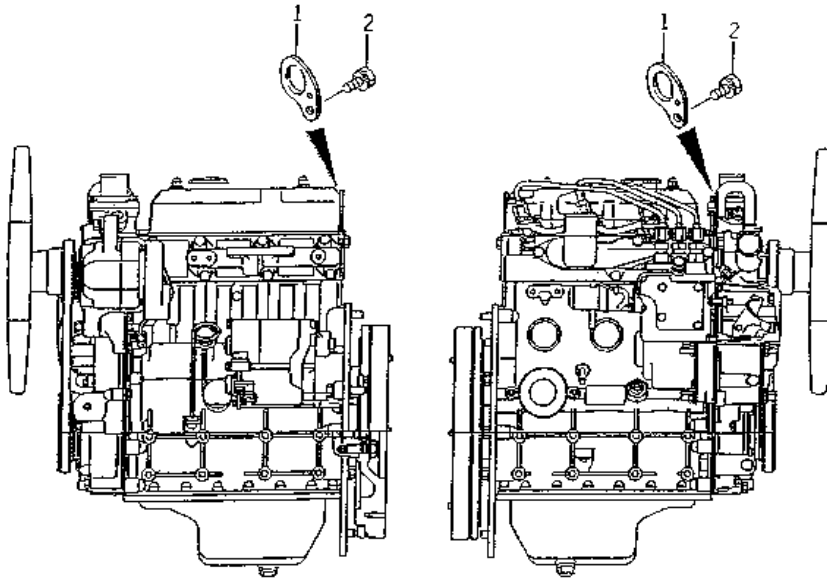

KEY	Part Code	Description	S P C	Type of Model						I T C	C O L	G R P	Remarks
				E311 2B07									
1	6211-777-007-20	HANGER	*	2									
2	6901-911-020-00	BOLT,SEMS/M10X20	*	2									

FIG. 11 VALVE

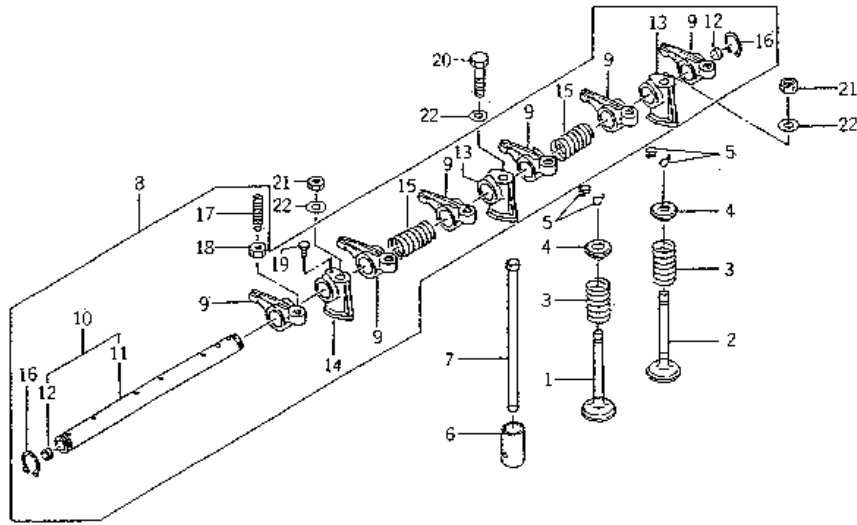

KEY	Part Code	Description	S P C	Type of Model					I T C	C O L	G R P	Remarks
				E311 2B07								
1	6212-551-001-00	VALVE,INTAKE	*	3								
2	6212-552-001-00	VALVE,EXHAUST	*	3								
3	6212-561-001-00	SPRING,VALVE	*	6								
4	6212-563-001-00	SEAT,VALVE SPRING	*	6								
5	6212-565-001-00	CUTTER,VALVE	*	12								
6	6212-571-003-00	TAPPET	*	6								
7	6212-575-002-00	ROD,PUSH	*	6								
8	6212-600-002-00	SHAFT,ROCKER ASSY	*	1								
9	6212-611-004-10	ROCKERARM	*	6								
10	6212-620-001-10	SHAFT,ROCKER ARMASSY	*	1								
11	6212-621-002-10	SHAFT/ROCKERARM	*	1								
12	6212-626-002-10	PLUG	*	2								
13	6212-628-004-00	BRACKET ROCKER SHAFT	*	2								
14	6212-628-005-00	BRACKET,ROCKER SHAFT	*	1								
15	6209-940-004-00	SPRING	*	2								
16	V704-140-016-00	RING,SNAP/16 C	*	2								
17	6212-616-002-00	SCREW ADJUST	*	6								
18	6209-409-003-00	NUT	*	6								
19	6209-000-002-00	BOLT	*	1								
20	6901-050-850-00	BOLT/M8X45	*	1								
21	6909-110-508-00	NUT/M8	*	2								
22	6209-500-005-00	WASHER/08X15.5X1.6	*	3								

FIG. 12 CAM SHAFT

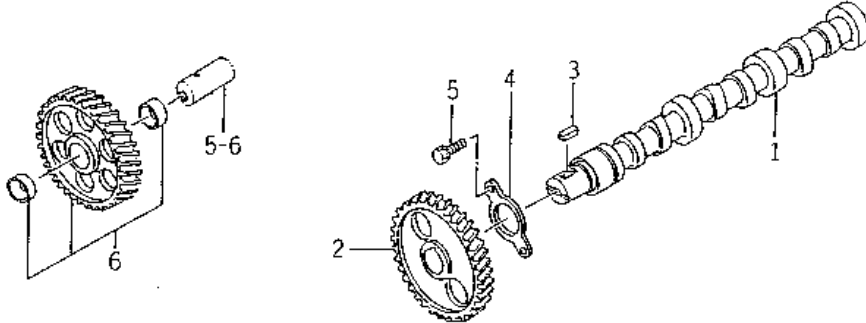

KEY	Part Code	Description	SPC	Type of Model					ITC	COL	GRP	Remarks
				E311 2B07								
1	6212-511-002-00	SHAFT,CAM	*	1								
2	6212-522-003-00	GEAR,CAMSHAFT	*	1								
3	6908-000-716-00	KEY	*	1								
4	6212-535-001-00	PLATE,THRUST	*	1								
5	6901-910-612-00	BOLT,SEMS/M6X12	*	2								
6	6212-523-003-00	GEAR,IDLE	*	1								

FIG. 13 PISTON

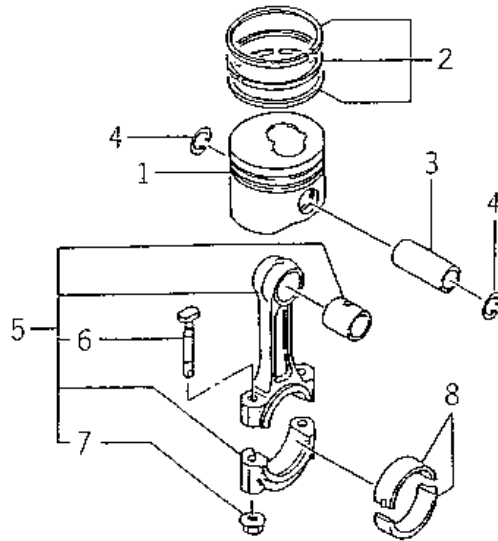

KEY	Part Code	Description	S P C	Type of Model					I T C	C O L	G R P	Remarks
				E311 2B07								
1	6212-111-055-10	PISTON	*	3								
2	6212-121-014-00	RING/PISTON SET	*	3								
3	6212-211-001-10	PIN,PISTON	*	3								
4	6209-587-001-00	RING,SNAP	*	6								
5	6212-230-004-00	ROD,CONN	*	3								
6	6212-235-001-10	BOLT/CONNECTINGROD	*	6								
7	6209-440-003-00	NUT/FLANGE	*	6								
8	6212-261-006-00	BEARING/CONN ROD	*	6								

04

FIG. 14 PISTON/OVER SIZE (OPTION)

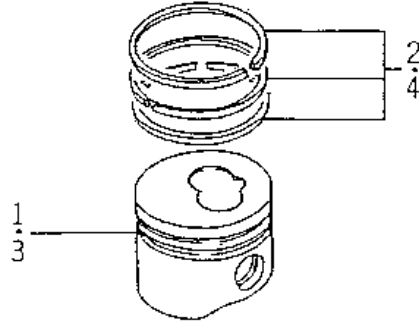

KEY	Part Code	Description	S P C	Type of Model						I T C	C O L	G R P	Remarks
				E311 2B07									
1	6212-114-055-10	PISTON/OV	T	3								050	
2	6212-124-014-00	RING/PISTON/OV SET	T	3								050	
3	6212-116-055-10	PISTON/OV	T	3								100	
4	6212-126-014-00	RING/PISTON/OV SET	T	3								100	

FIG. 15 CRANK SHAFT

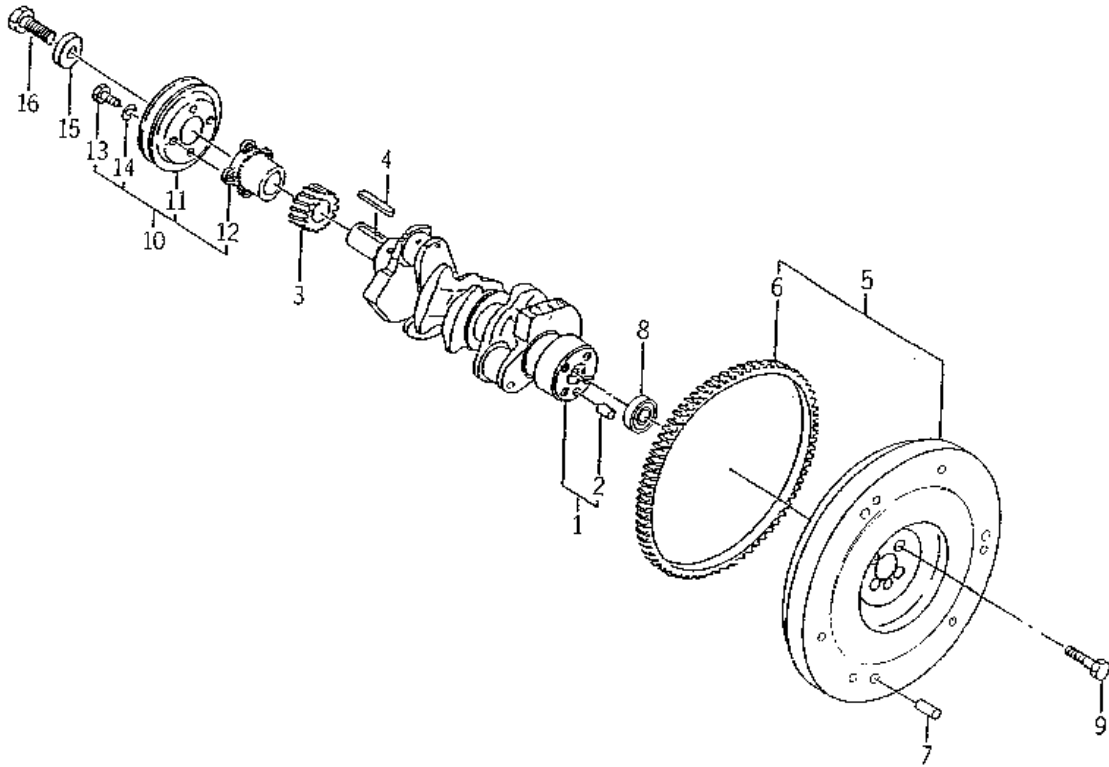

KEY	Part Code	Description	S P C	Type of Model					I T C	C O L	G R P	Remarks
				E311 2B07								
1	6212-310-009-00	SHAFT,CRANK ASSY	*	1								
2	V523-101-001-80	PIN	*	1								
3	6212-521-002-00	GEAR,CRANK SHAFT	*	1								
4	6908-000-750-00	KEY	*	1								
5	6212-330-049-10	FLYWHEEL ASSY	*	1								
6	6212-333-003-00	RINGGEAR	*	1								
7	6908-160-816-00	PIN	*	3								
8	V600-150-600-20	BEARING,RB/6002SS	*	1								
9	6209-000-013-00	BOLT	*	4								
10	6212-370-011-00	PULLEY ASSY	*	1								
11	6212-371-009-00	PULLEY	*	1								
12	6212-372-002-10	CENTER CRANK PULLEY	*	1								
13	6902-050-610-00	BOLT	*	4								
14	6909-150-506-00	WASHER,SP/M6	*	4								
15	6212-379-001-00	WASHER	*	1								
16	6901-066-645-00	BOLT	*	1								

FIG. 16 OIL PUMP

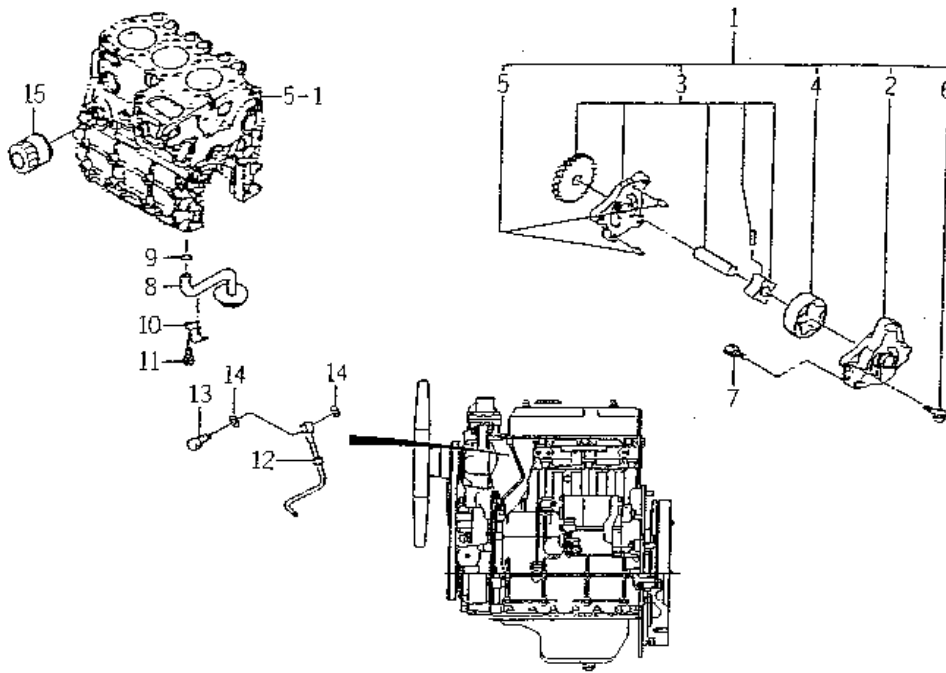

KEY	Part Code	Description	SPC	Type of Model						I	C	G	R	P	Remarks
				E311	2B07										
1	6213-100-003-30	OILPUMP ASSY	*	1											
2	6213-111-001-30	BODY/OILPUMP	*	1											
3	6213-120-003-20	GEAR/OILPUMP ASSY	*	1											
4	6213-125-001-00	ROTOR/OUTER	*	1											
5	6213-129-003-00	PIN/STRAIGHT	*	2											
6	6213-119-001-00	BOLT/WS	*	3											
7	6901-910-625-00	BOLT	*	3											
8	6213-140-008-00	STRAINER	*	1											
9	V720-102-401-50	O-RING/P15	*	1											
10	6213-149-002-00	CLAMP,STRAINER	*	1											
11	6901-910-816-00	BOLT,SEMS/M8X16	*	1											
12	6213-311-006-00	PIPE,OIL	*	1											
13	6909-906-105-10	BOLT,JOINT	*	1											
14	6209-920-002-00	PACKING	*	2											
15	6213-240-002-10	CARTRIDGE/OILFILTER	*	1											

FIG. 17 WATER PUMP

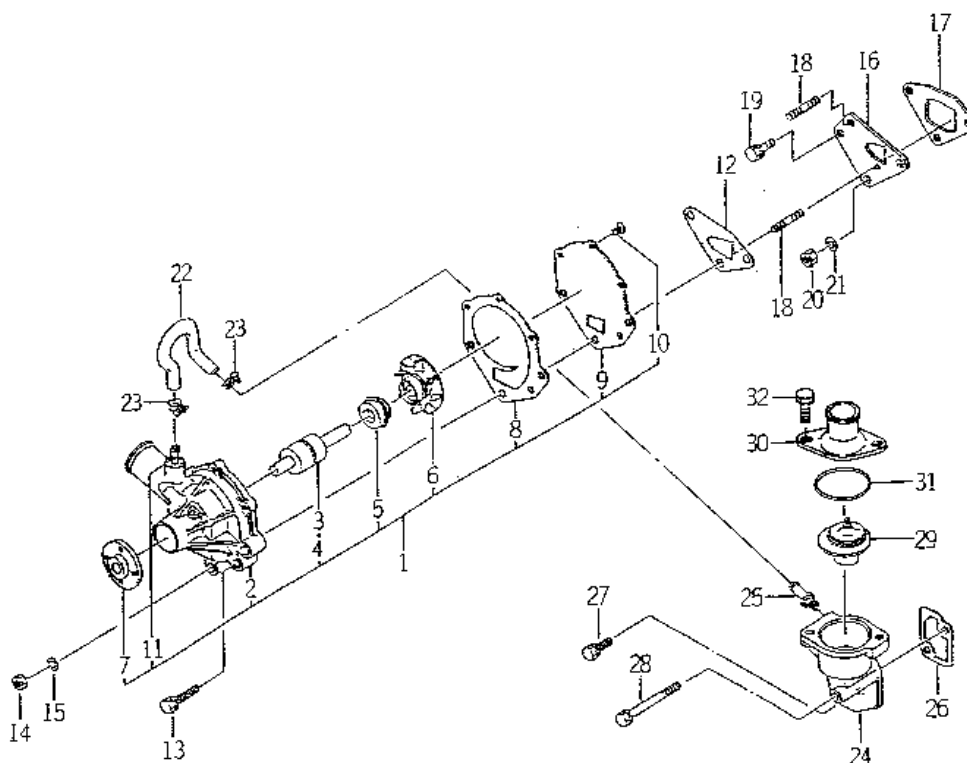

KEY	Part Code	Description	S P C	Type of Model					I T C	C O L	G R P	Remarks
				E311 2B07								
1	6213-610-005-40	WATERPUMP ASSY	*	1								
2	6213-611-003-20	BODY/WATERPUMP	*	1								
3	6213-631-002-00	BEARING/WATER PUMP	*	1								
4	6213-631-005-00	BEARING/WATERPUMP	*	1								
5	6213-622-002-10	SEAL SET/WATER PUMP	*	1								
6	6213-621-003-00	ROTOR/WATERPUMP	*	1								
7	6213-642-002-00	SEAL/WATER PUMPPULLE	*	1								
8	6213-613-002-10	GASKET	*	1								
9	6213-612-004-00	PLATE/WATER PUMP	*	1								
10	6213-619-003-00	SCREW/WATER PUMP	*	3								
11	6213-619-002-00	PIPE/WATER PUMP	*	2								
12	6213-614-003-10	GASKET/WATER PUMP	*	1								
13	6901-910-845-00	BOLT,SEMS/M8X45	*	1								
14	6909-110-508-00	NUT/M8	*	2								
15	6909-150-508-00	WASHER	*	2								
16	6213-619-001-00	SPACER,PUMP.WATER	*	1								
17	6213-614-004-10	GASKET,SPACER	*	1								
18	6904-110-840-00	STUD/M8X40	*	2								
19	V211-560-802-00	BOLT/M8X20	*	1								
20	6909-110-508-00	NUT/M8	*	1								
21	6909-150-508-00	WASHER	*	1								
22	6213-729-013-10	HOSE/RUBBER	*	1								
23	J061-210-015-00	CLAMP/WIRE/10-15	*	2								
24	6213-716-001-40	HOUSING/THERMOSTAT	*	1								
25	6213-721-003-00	PIPE,PUMP HOUSING	*	1								
26	6213-743-002-10	GASKET/HOUSING	*	1								
27	V211-560-802-00	BOLT/M8X20	*	1								
28	6209-030-006-00	BOLT/M8X75	*	1								
29	6513-770-022-10	THERMOSTAT	*	1								
30	6213-711-003-20	PIPE,WATER OUTLET	*	1								

FIG. 17 WATER PUMP

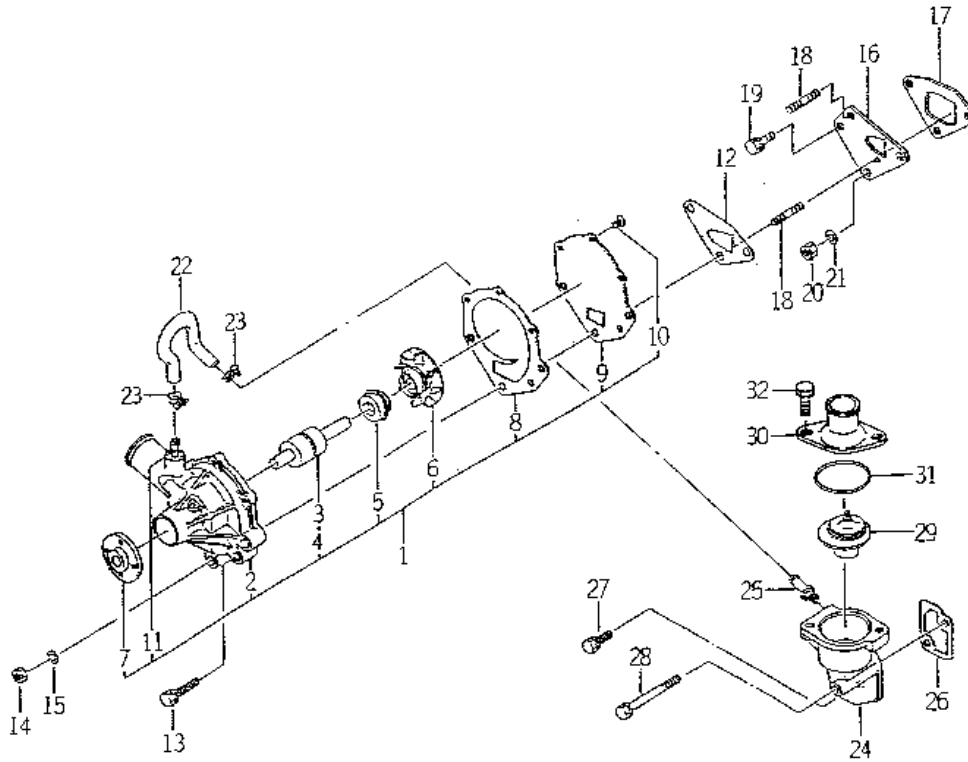

KEY	Part Code	Description	S P C	Type of Model						I T C	C O L	G R P	Remarks
				E311 2B07									
31	V723-102-005-50	O-RING	*	1									
32	6901-910-830-00	BOLT	*	2									

FIG. 18 COOLING FAN

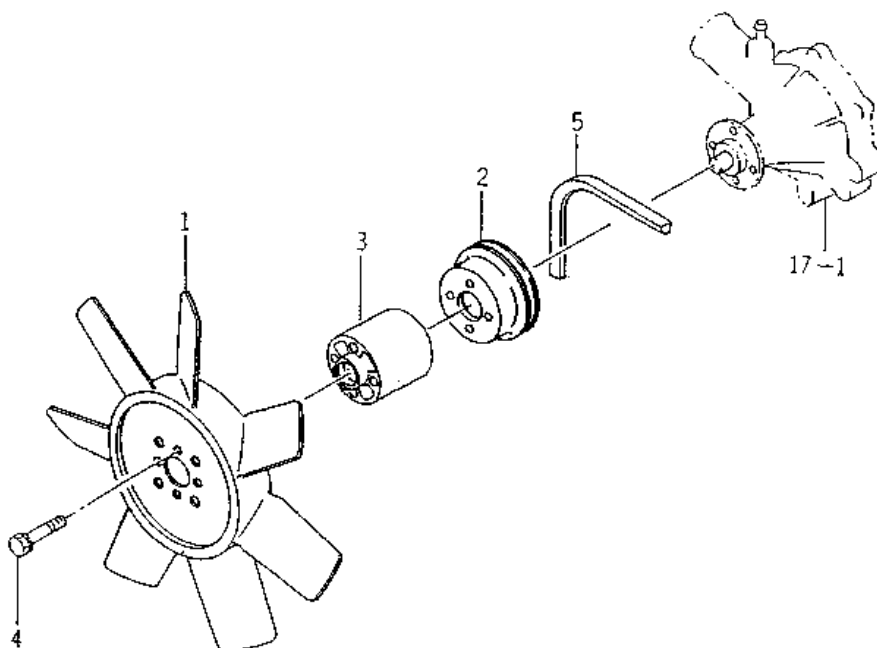

KEY	Part Code	Description	S P C	Type of Model					I T C	C O L	G R P	Remarks
				E311 2B07								
1	6213-660-007-00	FAN/COOLING	*	1								
2	6213-641-006-00	PULLEY,WATER PUMP	*	1								
3	6213-669-008-00	SPACER/FAN/48	*	1								
4	6209-030-092-00	BOLT/WS	*	4								
5	6213-671-003-00	BELT VHM034	*	1								

FIG. 19 INJECTION NOZZLE

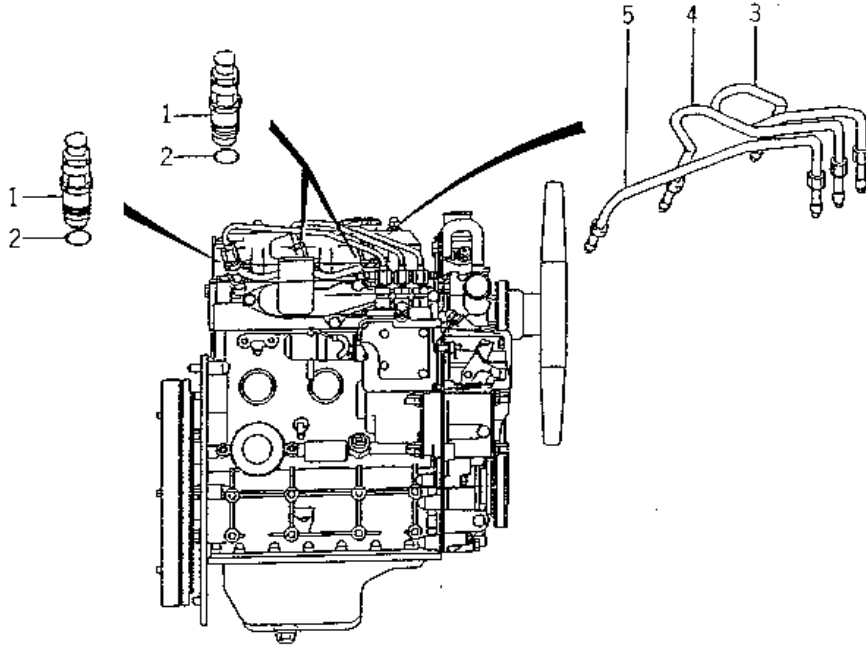

KEY	Part Code	Description	S P C	Type of Model						I T C	C O L	G R P	Remarks
				E311 2B07									
1	6215-300-036-00	INJECTIONNOZZLE ASSY	*	3								024	
2	6215-315-002-00	GASKET,NOZZLE	*	3									
3	6215-411-103-00	PIPE/INJECTION ASSY	*	1									
4	6215-411-104-00	PIPE/INJECTION ASSY	*	1									
5	6215-411-105-00	PIPE/INJECTION ASSY	*	1									

FIG. 20 INJECTION PUMP

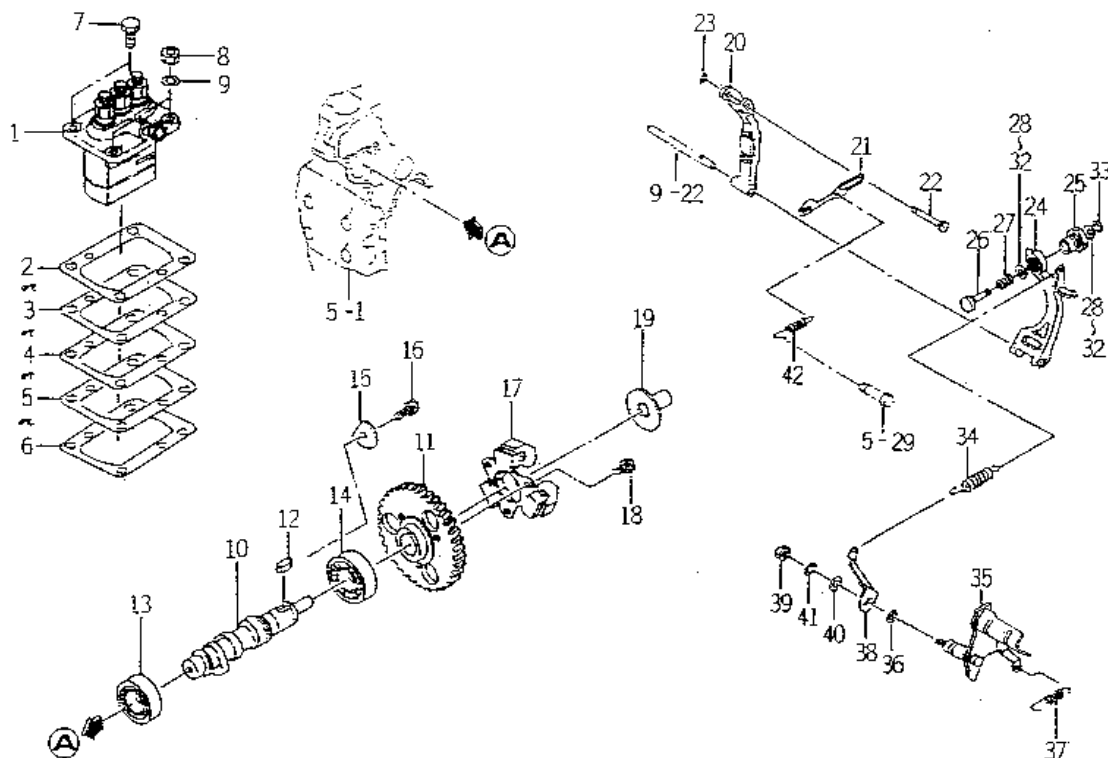

KEY	Part Code	Description	S P C	Type of Model					I T C	C O L	G R P	Remarks
				E311 2B07								
1	6215-600-103-10	INJECTIONPUMP ASSY	*	1							025	
2	6219-752-006-00	SHIM/PUMP,INJ	*	1								
3	6219-752-007-00	SHIM/PUMP,INJ	*	1								
4	6219-752-008-00	SHIM/PUMP,INJ	*	1								
5	6219-752-009-00	SHIM/PUMP,INJ	*	1								
6	6219-752-010-00	SHIM/PUMP,INJ	*	1								
7	V201-360-802-00	BOLT/M8X20	*	2								
8	6909-110-508-00	NUT/M8	*	2								
9	6909-150-508-00	WASHER	*	2								
10	6215-621-016-10	CAMSHAFT/INJ PUMP	*	1								
11	6212-524-002-00	GEAR,INJ PUMP	*	1								
12	6908-000-716-00	KEY	*	1								
13	V600-110-620-30	BEARING,RB/6203	*	1								
14	V600-110-600-40	BEARING,RB/6004	*	1								
15	6212-535-002-00	PLATE,THRUST INJPUMP	*	1								
16	6901-910-612-00	BOLT,SEMS/M6X12	*	1								
17	6215-520-001-00	FLYWEIGHT	*	1								
18	6209-030-043-00	BOLT/M6X10	*	3								
19	6215-526-001-10	PIECE,THRUST	*	1								
20	6215-541-001-10	ARM/FLOATING COMP	*	1								
21	6215-543-002-10	RINK/CONTROL	*	1								
22	6215-542-006-00	PIN,CONTROL	*	1								
23	V710-140-004-00	RING,SNAP/ 4 E	*	1								
24	6215-541-016-30	ARM/TENSION	*	1								
25	6215-549-028-10	CASE/ADAPTER	*	1								
26	6215-549-027-10	PIN/ADAPTER	*	1								
27	6215-549-034-00	SPRING/ADAPTER	*	1								
28	6215-549-006-00	SHIM,ADAPTER	*	2								
29	6215-549-009-00	SHIM,ADAPTER	*	2								
30	6215-549-010-00	SHIM,ADAPTER	*	2								

FIG. 20 INJECTION PUMP

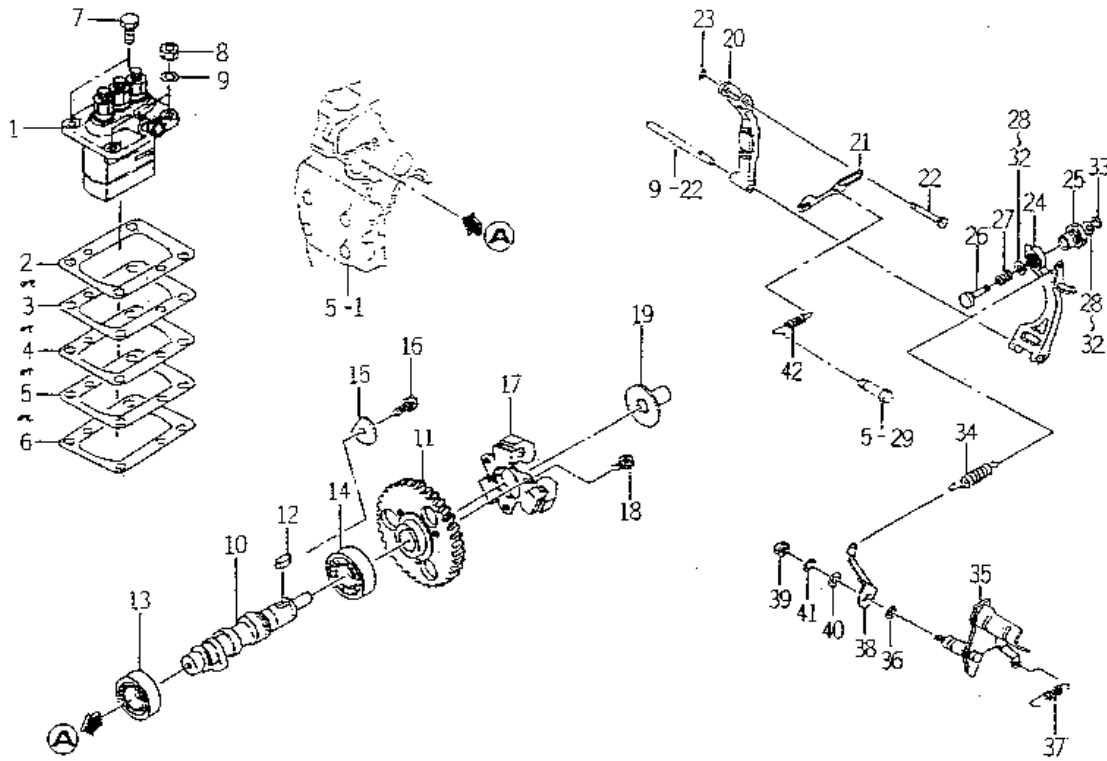

KEY	Part Code	Description	SPC	Type of Model					I T C	C O L	G R P	Remarks
				E311	2B07							
31	6215-549-023-00	SHIM/ADAPTER	*	1								
32	6215-549-024-00	SHIM/ADAPTER	*	1								
33	V710-140-004-00	RING,SNAP/ 4 E	*	1								
34	6215-531-008-00	SPRING/GOVERNOR	*	1								
35	6215-541-024-10	LEVER/CONTROL COMP	*	1								
36	V720-101-900-80	O-RING/P 8	*	1								
37	6209-580-002-10	SPRING,RETURN	*	1								
38	6215-549-007-10	ARM/CONTROL	*	1								
39	6909-110-406-00	NUT	*	1								
40	V411-260-006-00	WASHER / M6	*	1								
41	6909-150-506-00	WASHER,SP/M6	*	1								
42	6215-549-012-00	SPRING,STARTING	*	1								

FIG. 21 FUEL PIPE

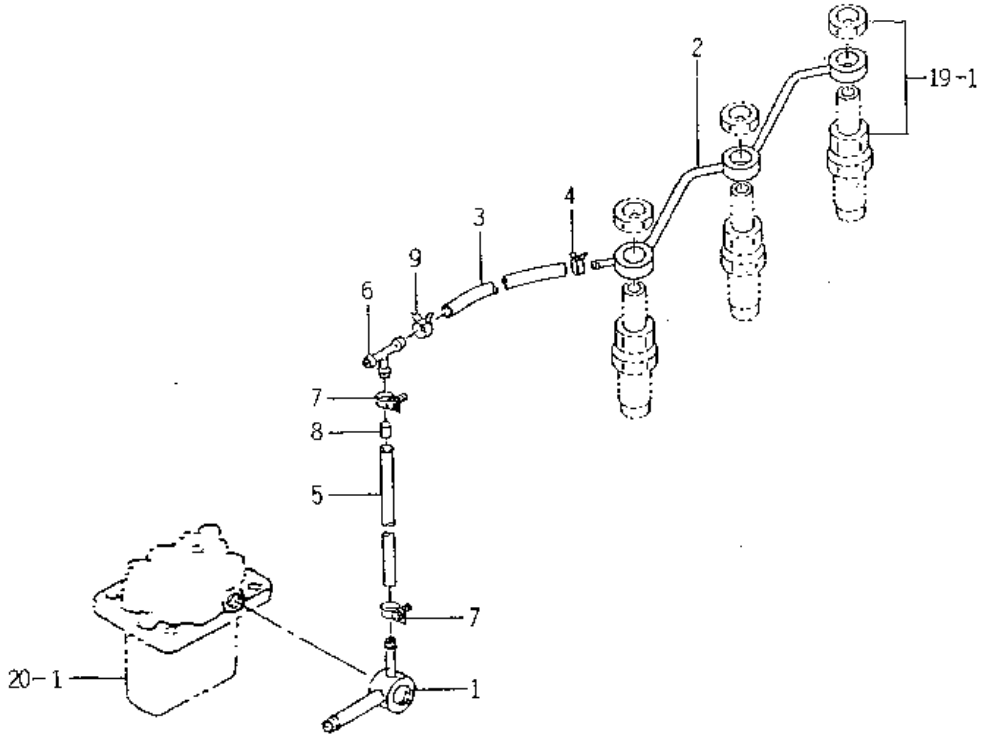

KEY	Part Code	Description	S P C	Type of Model					I T C	C O L	G R P	Remarks
				E311 2B07								
1	6215-412-002-10	CONNECTOR	*	1								
2	6215-411-074-10	PIPE/FUEL	*	1								
3	6209-360-005-00	HOSE,RUBBER	*	1								
4	J062-076-082-00	CLIP/HOSE/7.6-8.2	*	1								
5	6209-360-021-00	HOSE/RUBBER	*	1								
6	3632-360-036-00	JOINTT-TYPE 2	*	1								
7	J061-210-012-00	CLAMP/WIRE/10-12	*	2								
8	6215-419-001-00	TUBE,ORIFICE	*	1								
9	J062-087-093-00	CLIP/HOSE/8.7-9.3	*	1								

FIG. 22 ELECTRIC (1)

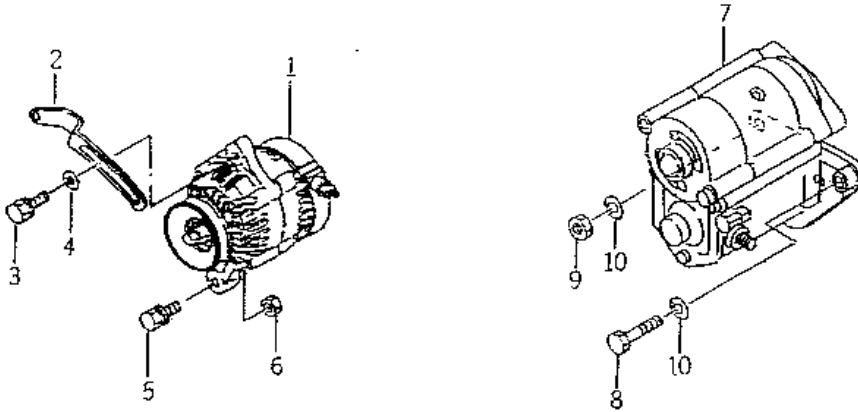

KEY	Part Code	Description	S P C	Type of Model						I T C	C O L	G R P	Remarks
				E311 2B07									
1	6281-200-005-00	GENERATOR ASSY	*	1								027	
2	6213-674-006-10	PLATE/ADJUST	*	1									
3	V211-560-802-00	BOLT/M8X20	*	1									
4	1373-121-001-00	WASHER/9X22X2	*	1									
5	6209-031-083-00	BOLT/WSP	*	1									
6	6909-110-410-00	NUT/M10	*	1									
7	6281-100-005-10	STARTER ASSY	*	1								026	
8	V203-361-004-50	BOLT	*	1									
9	6909-110-410-00	NUT/M10	*	1									
10	V401-160-010-00	WASHER,SP/M10	*	2									

FIG. 23 ELECTRIC (2)

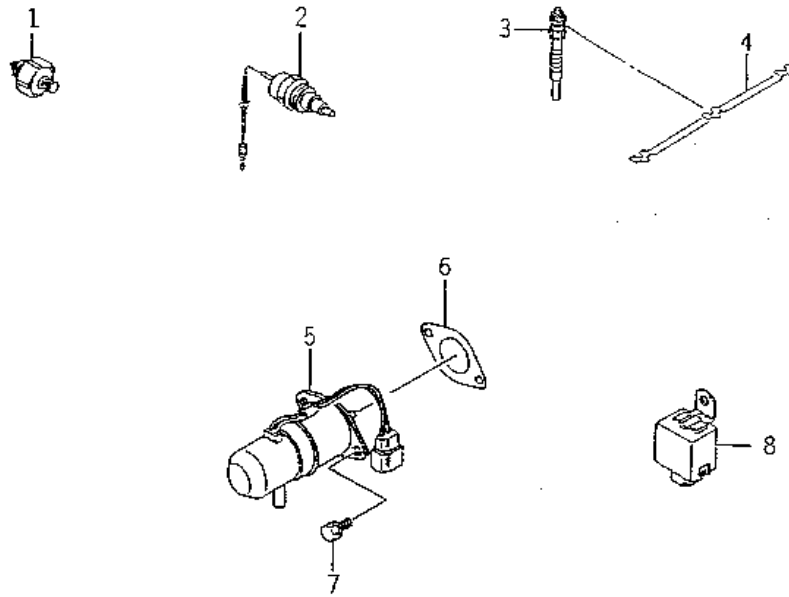

KEY	Part Code	Description	S P C	Type of Model						I T C	C O L	G R P	Remarks
				E311 2B07									
1	6281-971-003-00	SWITCH/OILPRESSURE	*	1									
2	6282-450-002-00	SWITCH/OVERHEAT	*	1									
3	6281-410-010-00	GLOWPLUG	*	3									
4	6219-732-002-00	CONNECTOR,GLOW PLUG	*	1									
5	6281-910-003-10	SOLENOID	*	1									
6	6209-630-002-10	GASKET	*	1									
7	6901-910-612-00	BOLT,SEMS/M6X12	*	2									
8	6281-920-001-00	RELAY,SOLENOID	*	1									

FIG. 24 COMPONENT PARTS FOR 6215 - 300 - 036 - 00 ON Fig.19

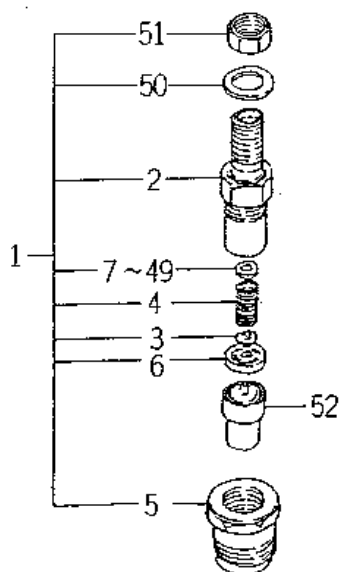

KEY	Part Code	Description	S P C	Type of Model					I T C	C O L	G R P	Remarks
				E311 2B07								
1	6215-330-024-00	HOLDER/NOZZLE ASSY	*	3								
2	6215-331-008-00	BODY/NOZZLE HOLDER	*	3								
3	6215-342-001-00	PIN,NOZZLE HOLDER	*	3								
4	6215-343-001-00	WASHER	*	3								
5	6215-332-013-00	NUT/NOZZLERETAINING	*	3								
6	6215-339-001-00	PIECE,DISTANCE	*	3								
7	6215-345-001-00	WASHER	*	3								
8	6215-345-002-00	WASHER	*	3								
9	6215-345-003-00	WASHER	*	3								
10	6215-345-004-00	WASHER	*	3								
11	6215-345-005-00	WASHER	*	3								
12	6215-345-006-00	WASHER	*	3								
13	6215-345-007-00	WASHER	*	3								
14	6215-345-008-00	WASHER	*	3								
15	6215-345-009-00	WASHER	*	3								
16	6215-345-010-00	WASHER	*	3								
17	6215-345-011-00	WASHER	*	3								
18	6215-345-012-00	WASHER	*	3								
19	6215-345-013-00	WASHER	*	3								
20	6215-345-014-00	WASHER	*	3								
21	6215-345-015-00	WASHER	*	3								
22	6215-345-016-00	WASHER	*	3								
23	6215-345-017-00	WASHER	*	3								
24	6215-345-018-00	WASHER	*	3								
25	6215-345-019-00	WASHER	*	3								
26	6215-345-020-00	WASHER	*	3								
27	6215-345-021-00	WASHER	*	3								
28	6215-345-022-00	WASHER	*	3								
29	6215-345-023-00	WASHER	*	3								
30	6215-345-024-00	WASHER	*	3								

FIG. 24 COMPONENT PARTS FOR 6215 – 300 – 036 – 00 ON Fig.19

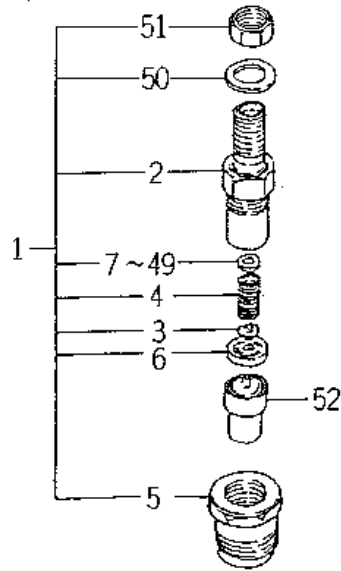

KEY	Part Code	Description	S P C	Type of Model						I T C	C O L	G R P	Remarks
				E311 2B07									
31	6215-345-025-00	WASHER	*	3									
32	6215-345-026-00	WASHER	*	3									
33	6215-345-027-00	WASHER	*	3									
34	6215-345-028-00	WASHER	*	3									
35	6215-345-029-00	WASHER	*	3									
36	6215-345-030-00	WASHER	*	3									
37	6215-345-031-00	WASHER	*	3									
38	6215-345-032-00	WASHER	*	3									
39	6215-345-033-00	WASHER	*	3									
40	6215-345-034-00	WASHER	*	3									
41	6215-345-035-00	WASHER	*	3									
42	6215-345-036-00	WASHER	*	3									
43	6215-345-037-00	WASHER	*	3									
44	6215-345-038-00	WASHER	*	3									
45	6215-345-039-00	WASHER	*	3									
46	6215-345-040-00	WASHER	*	3									
47	6215-345-041-00	WASHER	*	3									
48	6215-345-042-00	WASHER	*	3									
49	6215-345-043-00	WASHER	*	3									
50	6215-359-001-00	WASHER	*	3									
51	6215-359-002-00	NUT	*	3									
52	6215-311-027-00	NOZZLE ASSY	*	3									

FIG. 25 COMPONENT PARTS FOR 6215 - 600 - 103 - 10 ON Fig.20

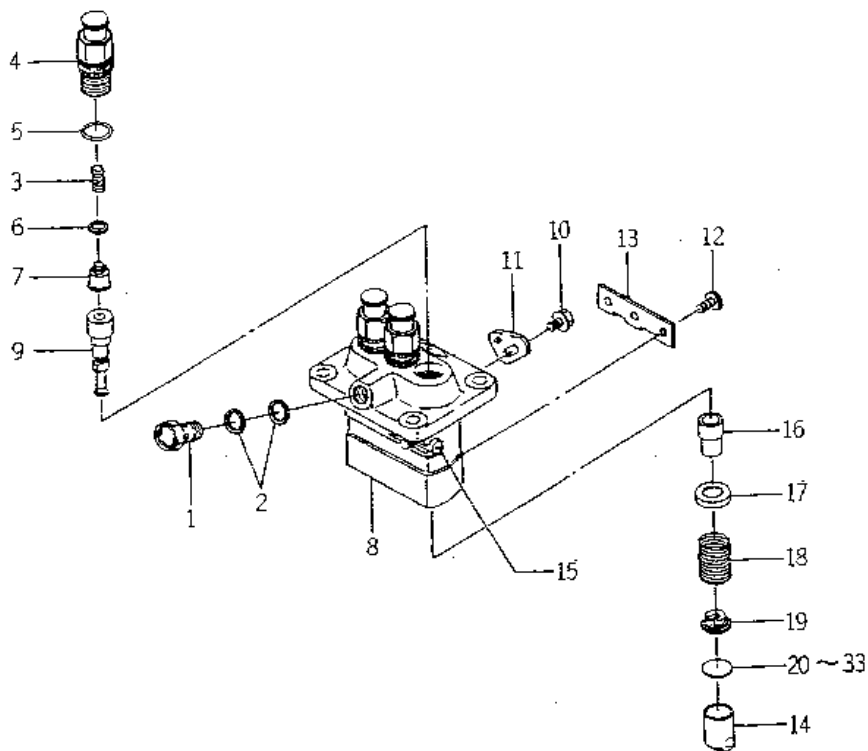

KEY	Part Code	Description	S P C	Type of Model						I T C	C O L	G R P	Remarks
				E311 2B07									
1	6215-619-009-00	SCREW/HOLLOW	*	1									
2	6215-619-010-00	WASHER/AIR BLEEDER	*	2									
3	6215-643-006-00	SPRING/DELIVERYVALVE	*	3									
4	6215-644-007-00	HOLDER/DELIVERYVALVE	*	3									
5	6215-649-001-00	ORING	*	3									
6	6215-649-002-00	GASKET/DELIVERYVALVE	*	3									
7	6215-641-006-00	VALVE ASSY	*	3									
8	6215-611-001-00	HOUSING ASSY	*	1									
9	6215-631-012-00	ELEMENT ASSY	*	3									
10	6215-619-022-00	BOLT/WASHERHEAD	*	2									
11	6215-612-001-00	PLATE/ADJUSTING	*	2									
12	6215-629-001-00	PIN/INJECTIONPUMP	*	3									
13	6215-629-002-00	PLATE	*	1									
14	6215-622-001-00	TAPPET/INJECTIO ASSY	*	3									
15	6215-637-001-00	RACK/CONTROL ASSY	*	1									
16	6215-635-001-00	SLEEVE/PLUNGER	*	3									
17	6215-639-004-00	SEAT/SPRING/UPPER	*	3									
18	6215-634-001-00	SPRING/PUMPPLUNGER	*	3									
19	6215-639-005-00	SEAT/SPRING/LOWER	*	3									
20	6215-629-003-00	PLATE/TAPPET/ADJUST	*	1									
21	6215-629-004-00	PLATE/TAPPET/ADJUST	*	1									
22	6215-629-005-00	PLATE/TAPPET/ADJUST	*	1									
23	6215-629-006-00	PLATE/TAPPET/ADJUST	*	1									
24	6215-629-007-00	PLATE/TAPPET/ADJUST	*	1									
25	6215-629-008-00	PLATE/TAPPET/ADJUST	*	1									
26	6215-629-009-00	PLATE/TAPPET/ADJUST	*	1									
27	6215-629-010-00	PLATE/TAPPET/ADJUST	*	1									
28	6215-629-011-00	PLATE/TAPPET/ADJUST	*	1									
29	6215-629-012-00	PLATE/TAPPET/ADJUST	*	1									
30	6215-629-013-00	PLATE/TAPPET/ADJUST	*	1									

FIG. 25 COMPONENT PARTS FOR 6215 – 600 – 103 – 10 ON Fig.20

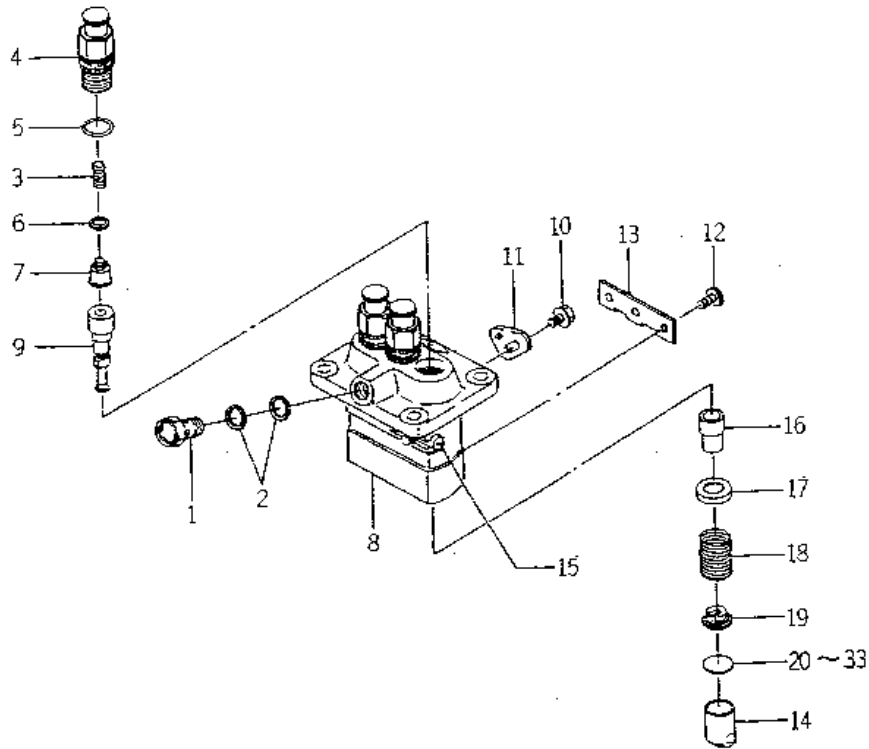

KEY	Part Code	Description	S P C	Type of Model					I T C	C O L	G R P	Remarks
				E311 2B07								
31	6215-629-014-00	PLATE/TAPPET/ADJUST	*	1								
32	6215-629-015-00	PLATE/TAPPET/ADJUST	*	1								
33	6215-629-016-00	PLATE/TAPPET/ADJUST	*	1								

FIG. 26 COMPONENT PARTS FOR 6281 – 100 – 005 – 10 ON Fig.22

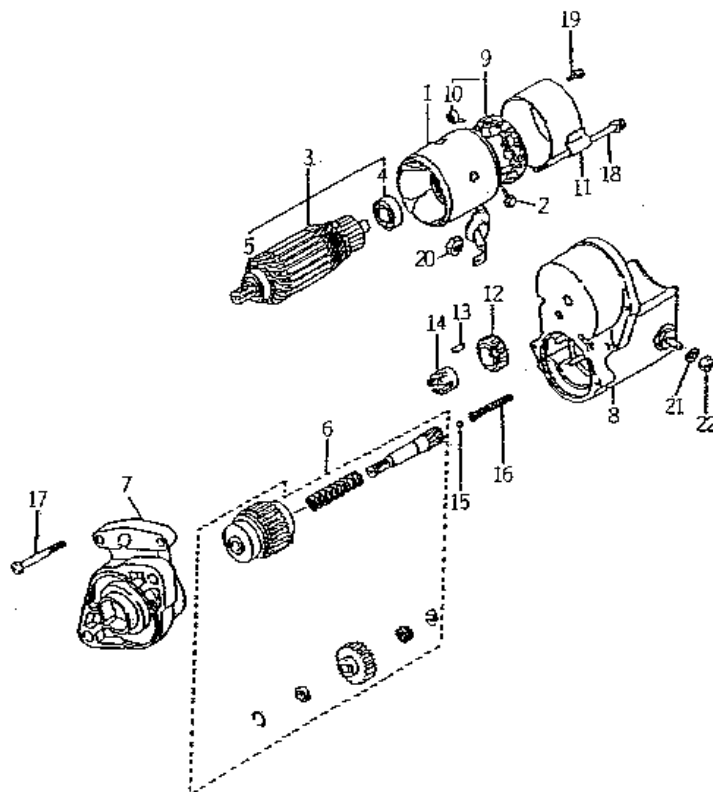

KEY	Part Code	Description	S P C	Type of Model					I T C	C O L	G R P	Remarks
				E311 2B07								
1	6281-111-002-00	YOKE/STARTER	*	1								
2	6281-116-002-00	STARTER KIT	*	2								
3	6281-121-003-00	ARMATURE	*	1								
4	6281-129-010-00	BEARING,BALL	*	1								
5	6281-129-011-00	BEARING,BALL	*	1								
6	6281-124-001-00	STARTER KIT	*	1								
7	6281-129-020-00	HOUSING,STARTER ASSY	*	1								
8	6281-151-005-10	SWITCH/STARTER ASSY	*	1								
9	6281-118-002-00	HOLDER BRUSH ASSY	*	1								
10	6581-117-007-00	SPRING,BRUSH	*	4								
11	6281-115-005-00	FRAME,STARTER END	*	1								
12	6581-123-011-00	PINION,STARTER	*	1								
13	6581-129-099-00	RORA	*	5								
14	6581-129-100-00	RETAINER	*	1								
15	6581-129-092-00	BALL	*	1								
16	6581-129-096-00	SPRING	*	1								
17	6281-129-006-00	SCREW	*	2								
18	6281-129-008-00	BOLT/WS	*	2								
19	6281-129-009-00	SCREW/WS	*	2								
20	6909-111-508-00	NUT	*	1								
21	6909-150-508-00	WASHER	*	1								
22	6909-110-408-00	NUT/M8	*	1								

FIG. 27 COMPONENT PARTS FOR 6281 - 200 - 005 - 00 ON Fig.22

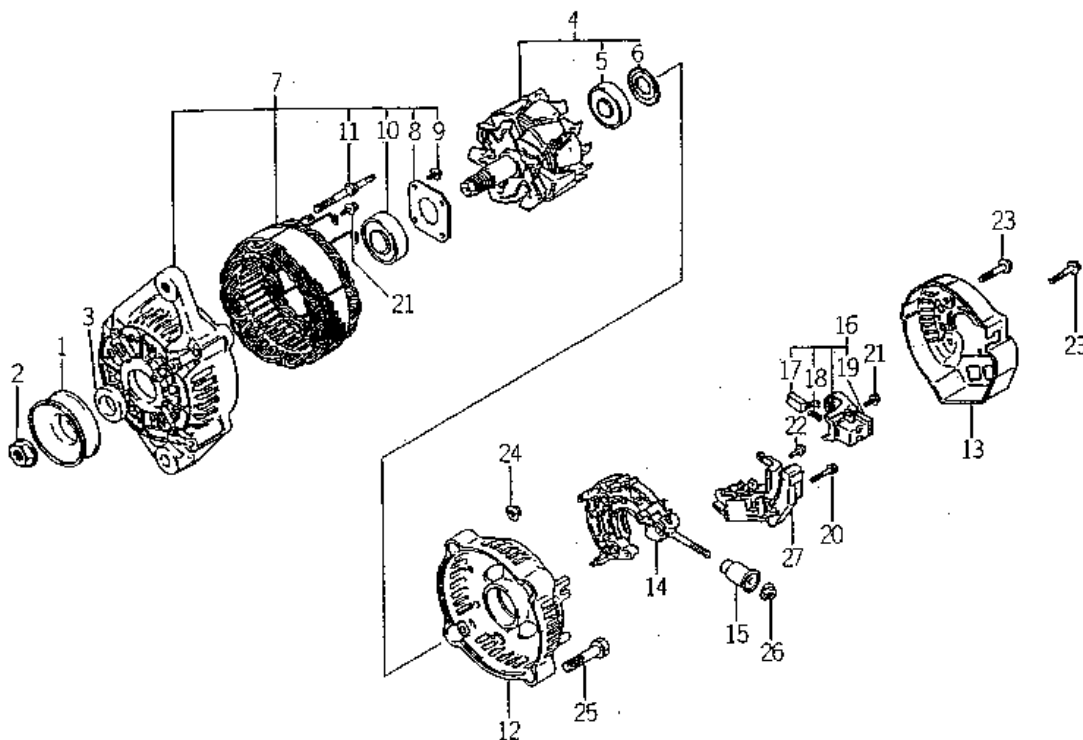

KEY	Part Code	Description	S P C	Type of Model						I T C	C O L	G R P	Remarks
				E311 2B07									
1	6281-222-004-00	PULLEY	*	1									
2	6281-229-002-00	NUT	*	1									
3	6281-229-003-00	COLLOR	*	1									
4	6281-221-001-00	ROTOR ASSY	*	1									
5	6281-229-005-00	BEARING	*	1									
6	6281-229-004-00	COVER,BEARING	*	1									
7	6281-213-006-00	FRAME ASSY	*	1									
8	6281-229-006-00	PLATE	*	1									
9	6281-229-007-00	BOLT	*	4									
10	6281-229-009-00	BEARING	*	1									
11	6281-229-008-00	BOLT	*	2									
12	6281-214-003-00	FRAME	*	1									
13	6281-214-004-00	COVER	*	1									
14	6281-229-029-00	HOLDER ASSY	*	1									
15	6281-229-011-00	BUSH	*	1									
16	6281-217-001-00	HOLDER,BRUSH ASSY	*	1									
17	6281-215-001-00	BRUSH	*	2									
18	6281-216-001-00	SPRING	*	2									
19	6281-229-019-00	SEAL,RING	*	1									
20	6281-229-012-00	BOLT	*	2									
21	6281-229-013-00	BOLT	*	6									
22	6281-229-014-00	BOLT	*	1									
23	6281-229-015-00	BOLT	*	3									
24	6281-229-016-00	NUT	*	2									
25	6281-229-017-00	BOLT	*	2									
26	6281-229-018-00	NUT	*	1									
27	6281-271-002-00	REGULATOR ASSY	*	1									