

# 目 次

## SCMB48 chassis

|                                       |          |
|---------------------------------------|----------|
| Joint (Universal) system.....         | Fig. 101 |
| Cover (Joint) system.....             | Fig. 102 |
| Pulley System.....                    | Fig. 201 |
| Case (Bevel) system.....              | Fig. 202 |
| Belt System.....                      | Fig. 203 |
| Collar (Blade) system.....            | Fig. 301 |
| Blade System.....                     | Fig. 302 |
| Deck (Mower) system.....              | Fig. 401 |
| Cover (Discharge) system.....         | Fig. 402 |
| Cover System.....                     | Fig. 403 |
| Wheel (Gauge) system.....             | Fig. 501 |
| Link System.....                      | Fig. 601 |
| Label.....                            | Fig. 901 |
| Label (Ce).....                       | Fig. 902 |
| Pin (Safety).....                     | Fig. 903 |
| Case (Bevel) assy (Repair) (1/2)..... | Fig. P01 |
| Component Parts.....                  | Fig. S01 |

## Directions for use of Parts Catalogue

### 1. Applicable model of machines

All component and option parts used for SCMB48Mower and SBC600X Collector are listed in this parts catalogue.

NOTES: SCMB48-SXG326E4..... FOR SXG326, 323  
 SBC600X-HQE4..... FOR SXG326, 323

### 2. Explanation for head paragraph

| KEY | PART CODE       | DESCRIPTION | SPC | TYPE OF MODEL |        |        |        |        |        | I T C | C O L | G R P | REMARKS |
|-----|-----------------|-------------|-----|---------------|--------|--------|--------|--------|--------|-------|-------|-------|---------|
|     |                 |             |     | SSM48M        | SSM48F | SSM48G | SRM48M | SRM48F | SRM48G |       |       |       |         |
| 1   | 8585-211-001-20 | CASE/UPPER  | *   | L             |        |        |        |        |        |       |       |       |         |
| 1A  | 8657-201-001-00 | CASE/UPPER  | *   | L             |        |        |        |        |        |       |       |       |         |
| 2   | 8585-211-002-10 | CASE/LOWER  | *   | L             |        |        |        |        |        |       |       |       |         |
| 3   | V523-100-801-80 | PIN         | *   |               |        |        |        |        |        |       |       |       |         |
| 4   | V211-260-803-00 | BOLT, SEWS  | *   |               |        |        |        |        |        |       |       |       |         |

- ① KEY shows the location of parts diagramed in the illustration.
- ② Parts numbers begin with `V` and `W` are standard parts of the market.
- ③ `LH` and `RH` on the parts name are described against the moving direction of the machine or are described on the condition how to install parts on the machines.
- ④ SPC : The following symbol classifies parts to be used for machines.  
 `\*` means standard parts.  
 `T` shows that the parts can be installed as optional parts.  
 `R` shows that the parts can be used as applicable parts to replace originally equipped parts.
- ⑤ Upper column : QTY shows the number of parts to be used for one unit of

machine.

‘M’ is indicated for parts supplied by a meter long.

‘l’ is indicated for parts supplied by liter.

‘AR’ is indicated for parts need to be adjusted or regulated.

Lower column : serial number

–229 means serial number up to 229.

230– means serial number 230 and after.

⑥ ITC : Interchangeability

‘1’…OLD ← NEW

New parts can be used in place of the old parts.

‘2’…OLD → NEW

Old parts can be used in place of the new parts.

‘3’…OLD →← NEW

Old parts and new parts can not be replaced each other.

⑦ COL : Color code

Color is signified with color code number for colored parts.

Please see the color list shown in the next page.

⑧ GRP : Parts shown in this column can be replaced by SET parts.

Example : Parts marked ㉔ can be replaced by parts marked ㉕, and ㉖ for ㉗, so the rest follow in the same alphabetical order.

⑨ Remarks

\* Other maker’s part code number is shown in this column.

\* When Fig. No. is shown in the Remark column of SET parts or ASSY parts, each of their component parts are listed in said Fig. No.

3. Color :

The following colors are used color parts.

| COLOR CODE | COLOR        | SPRAY TYPE PARTS CODE | PAINTS 4K DRUM PARTS CODE | PAINTS 16K DRUM PARTS CODE |
|------------|--------------|-----------------------|---------------------------|----------------------------|
| 7 F        | MIRROR BLACK | 1300-954-001-10       | 1300-954-003-00           | 1300-954-004-00            |

NOTE : Color code is signified only for the parts assigned by the maker as color parts.

4. Serial Numbers :

For chassies serial number is shown on the LABEL.

Please see



## 5. Parts Order

- 1) When you order parts, please make sure of correct numbers.
- 2) When substitute parts is available, the part number ordered will be automatically turned to a new part number.
- 3) Please be sure to use "ISEKI GENUINE PARTS".

Any other similar parts other than ISEKI parts when used may cause a trouble that makes us unable to repair or guarantee the warrant.

**\*\*\* Structure Table of Model \*\*\***

|                       |  |  |  |  |  |  |  |  |  |  |  |
|-----------------------|--|--|--|--|--|--|--|--|--|--|--|
| M<br>O<br>D<br>E<br>L | S<br>C<br>M<br>S<br>B<br>X<br>4<br>G<br>8<br>3<br>2<br>6<br>E<br>4 |  |  |  |  |  |  |  |  |  |  |
| FIG.                  |  |  |  |  |  |  |  |  |  |  |  |
| 101                   | *  |  |  |  |  |  |  |  |  |  |  |
| 102                   | *  |  |  |  |  |  |  |  |  |  |  |
| 201                   | *  |  |  |  |  |  |  |  |  |  |  |
| 202                   | *  |  |  |  |  |  |  |  |  |  |  |
| 203                   | *  |  |  |  |  |  |  |  |  |  |  |
| 301                   | *  |  |  |  |  |  |  |  |  |  |  |
| 302                   | *  |  |  |  |  |  |  |  |  |  |  |
| 401                   | *  |  |  |  |  |  |  |  |  |  |  |
| 402                   | *  |  |  |  |  |  |  |  |  |  |  |
| 403                   | *  |  |  |  |  |  |  |  |  |  |  |
| 501                   | *  |  |  |  |  |  |  |  |  |  |  |
| 601                   | *  |  |  |  |  |  |  |  |  |  |  |
| 901                   | *  |  |  |  |  |  |  |  |  |  |  |
| 902                   | *  |  |  |  |  |  |  |  |  |  |  |
| 903                   | *  |  |  |  |  |  |  |  |  |  |  |
| P01                   | R  |  |  |  |  |  |  |  |  |  |  |
| P01-A                 | R  |  |  |  |  |  |  |  |  |  |  |
| S01                   | *  |  |  |  |  |  |  |  |  |  |  |
|                       |  |  |  |  |  |  |  |  |  |  |  |
|                       |  |  |  |  |  |  |  |  |  |  |  |
|                       |  |  |  |  |  |  |  |  |  |  |  |
|                       |  |  |  |  |  |  |  |  |  |  |  |
|                       |  |  |  |  |  |  |  |  |  |  |  |
|                       |  |  |  |  |  |  |  |  |  |  |  |
|                       |  |  |  |  |  |  |  |  |  |  |  |

8674-095-100-0A FIG.000 PICTURE CONTENTS

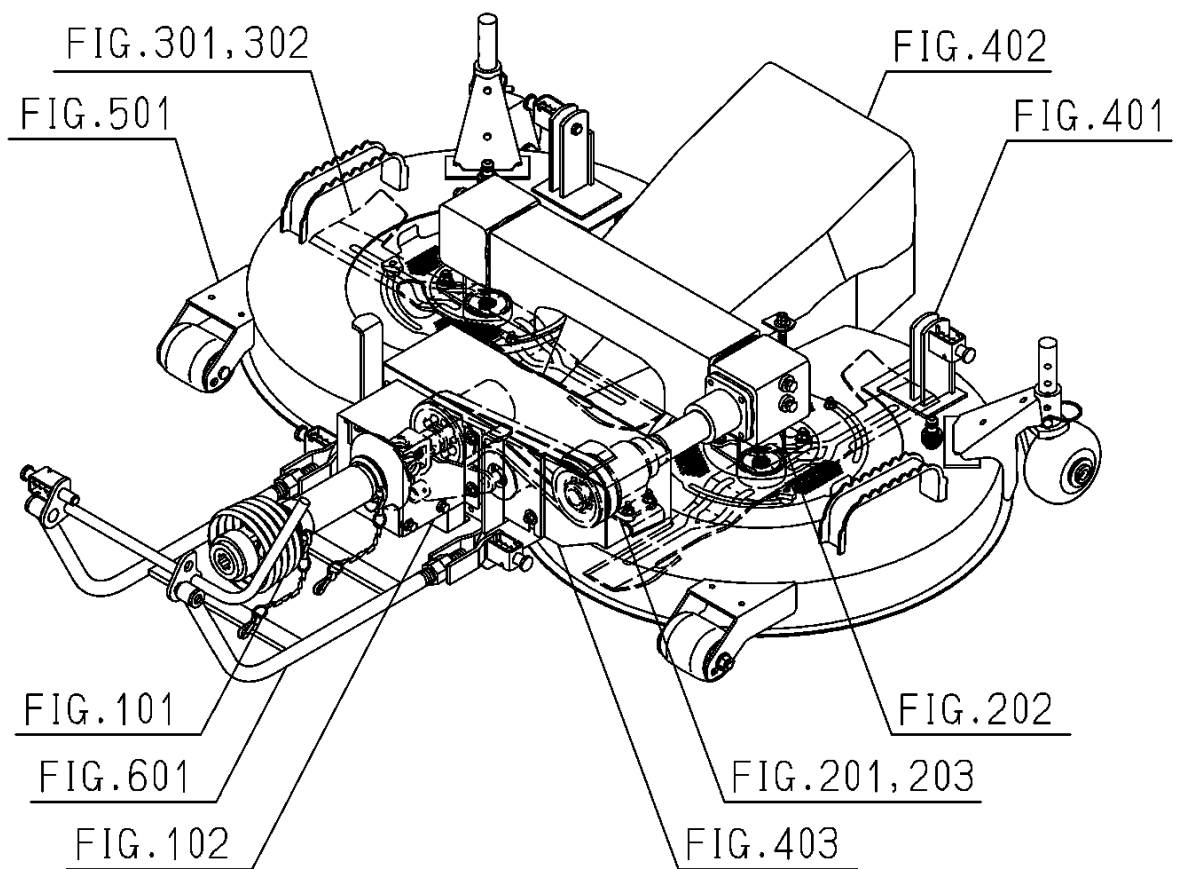
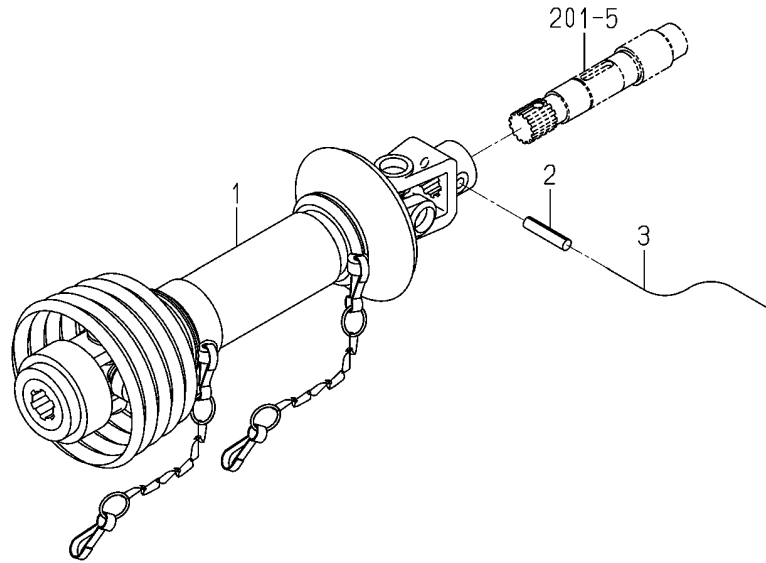
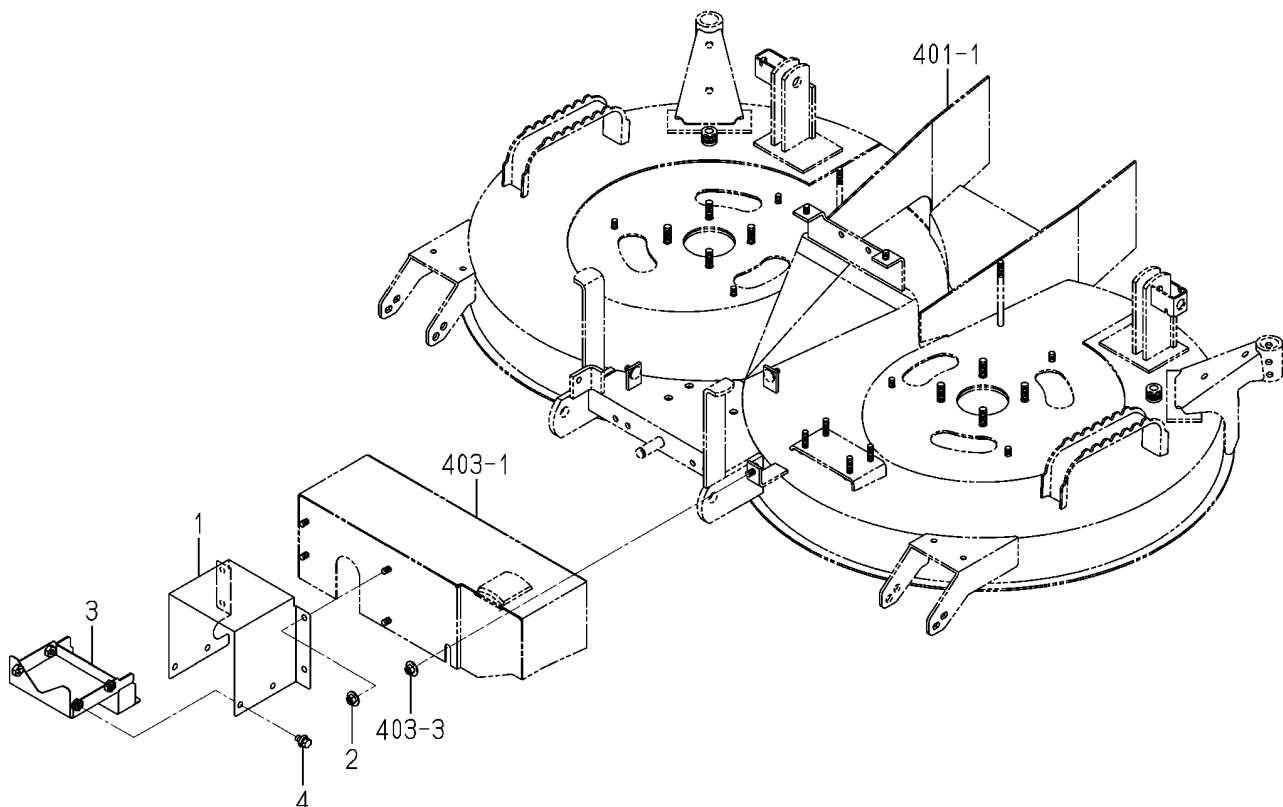


FIG.101 JOINT(UNIVERSAL)SYSTEM



| 図番 | 部品コード           | 品名                  | 仕様 | 型式  |     |  |  |  |  | 代替性 | 色番号 | グループ | 備考  |
|----|-----------------|---------------------|----|-----|-----|--|--|--|--|-----|-----|------|-----|
|    |                 |                     |    | SCM | B48 |  |  |  |  |     |     |      |     |
| 1  | 8663-101-510-00 | JOINT/UNIVERSAL SET | *  | 1   |     |  |  |  |  |     |     |      | S01 |
| 2  | V580-140-804-00 | PIN, SPRING/8 X40 W | *  | 1   |     |  |  |  |  |     |     |      |     |
| 3  |                 | WIRE                | *  | 1   |     |  |  |  |  |     |     |      |     |
|    |                 |                     |    |     |     |  |  |  |  |     |     |      |     |
|    |                 |                     |    |     |     |  |  |  |  |     |     |      |     |
|    |                 |                     |    |     |     |  |  |  |  |     |     |      |     |
|    |                 |                     |    |     |     |  |  |  |  |     |     |      |     |
|    |                 |                     |    |     |     |  |  |  |  |     |     |      |     |
|    |                 |                     |    |     |     |  |  |  |  |     |     |      |     |
|    |                 |                     |    |     |     |  |  |  |  |     |     |      |     |
|    |                 |                     |    |     |     |  |  |  |  |     |     |      |     |
|    |                 |                     |    |     |     |  |  |  |  |     |     |      |     |
|    |                 |                     |    |     |     |  |  |  |  |     |     |      |     |
|    |                 |                     |    |     |     |  |  |  |  |     |     |      |     |
|    |                 |                     |    |     |     |  |  |  |  |     |     |      |     |
|    |                 |                     |    |     |     |  |  |  |  |     |     |      |     |
|    |                 |                     |    |     |     |  |  |  |  |     |     |      |     |
|    |                 |                     |    |     |     |  |  |  |  |     |     |      |     |
|    |                 |                     |    |     |     |  |  |  |  |     |     |      |     |
|    |                 |                     |    |     |     |  |  |  |  |     |     |      |     |
|    |                 |                     |    |     |     |  |  |  |  |     |     |      |     |
|    |                 |                     |    |     |     |  |  |  |  |     |     |      |     |
|    |                 |                     |    |     |     |  |  |  |  |     |     |      |     |

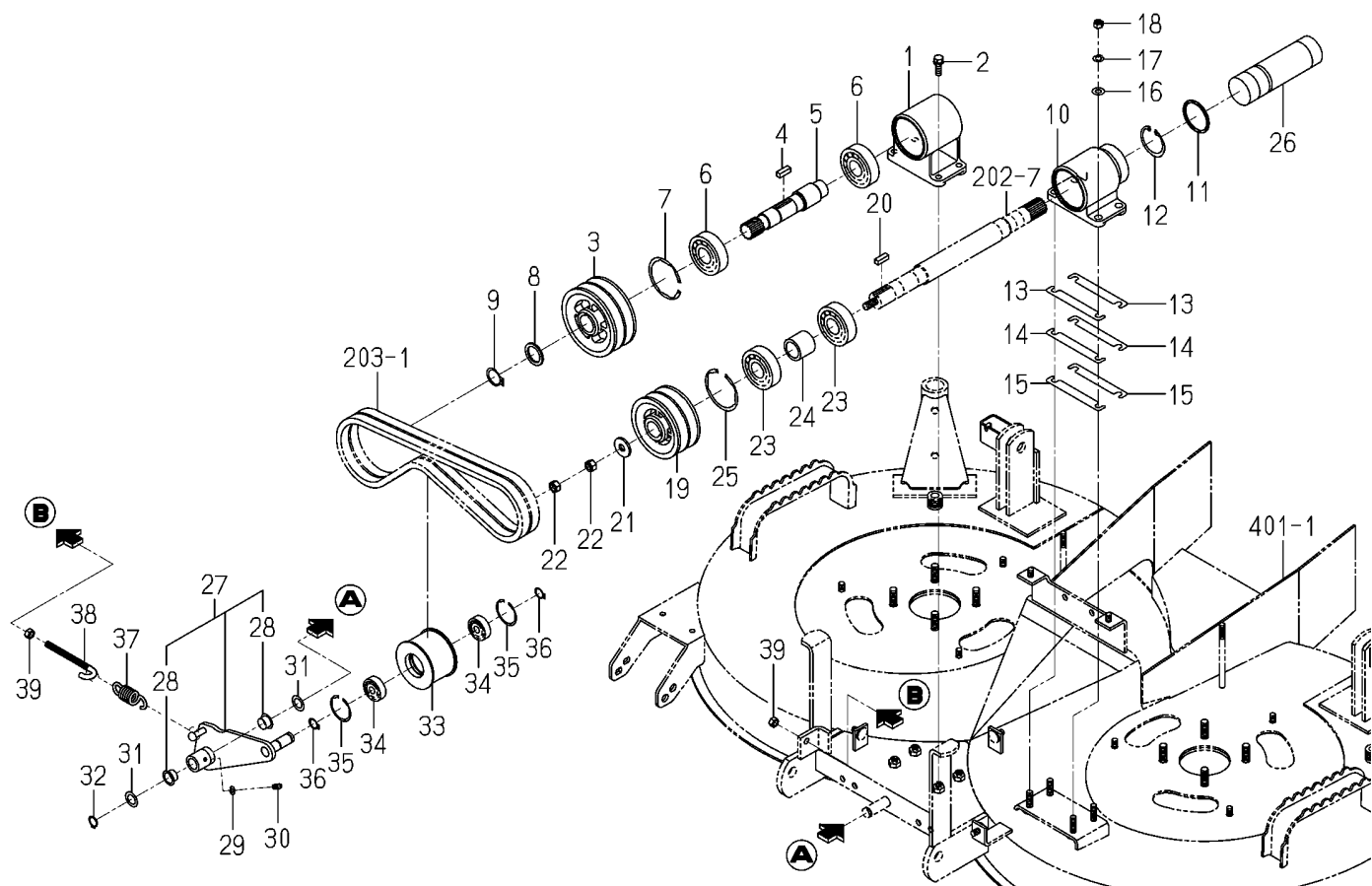
FIG.102 COVER(JOINT)SYSTEM



| 図番 | 部品コード           | 品名              | 仕様 | 型式         |  |  |  |  | 代替性 | 色番号 | グループ | 備考 |
|----|-----------------|-----------------|----|------------|--|--|--|--|-----|-----|------|----|
|    |                 |                 |    | SCM<br>B48 |  |  |  |  |     |     |      |    |
| 1  | 8663-407-052-00 | COVER/JOINT     | *  | 1          |  |  |  |  |     | 7F  |      |    |
| 2  | V363-260-008-00 | NUT/WASHER      | *  | 4          |  |  |  |  |     |     |      |    |
| 3  | 8663-407-540-10 | COVER/YOKE COMP | *  | 1          |  |  |  |  |     | 7F  |      |    |
| 4  | V211-360-801-60 | BOLT, SEMS (SP) | *  | 4          |  |  |  |  |     |     |      |    |
|    |                 |                 |    |            |  |  |  |  |     |     |      |    |
|    |                 |                 |    |            |  |  |  |  |     |     |      |    |
|    |                 |                 |    |            |  |  |  |  |     |     |      |    |
|    |                 |                 |    |            |  |  |  |  |     |     |      |    |
|    |                 |                 |    |            |  |  |  |  |     |     |      |    |
|    |                 |                 |    |            |  |  |  |  |     |     |      |    |
|    |                 |                 |    |            |  |  |  |  |     |     |      |    |
|    |                 |                 |    |            |  |  |  |  |     |     |      |    |
|    |                 |                 |    |            |  |  |  |  |     |     |      |    |
|    |                 |                 |    |            |  |  |  |  |     |     |      |    |
|    |                 |                 |    |            |  |  |  |  |     |     |      |    |
|    |                 |                 |    |            |  |  |  |  |     |     |      |    |
|    |                 |                 |    |            |  |  |  |  |     |     |      |    |
|    |                 |                 |    |            |  |  |  |  |     |     |      |    |
|    |                 |                 |    |            |  |  |  |  |     |     |      |    |
|    |                 |                 |    |            |  |  |  |  |     |     |      |    |
|    |                 |                 |    |            |  |  |  |  |     |     |      |    |
|    |                 |                 |    |            |  |  |  |  |     |     |      |    |
|    |                 |                 |    |            |  |  |  |  |     |     |      |    |
|    |                 |                 |    |            |  |  |  |  |     |     |      |    |
|    |                 |                 |    |            |  |  |  |  |     |     |      |    |

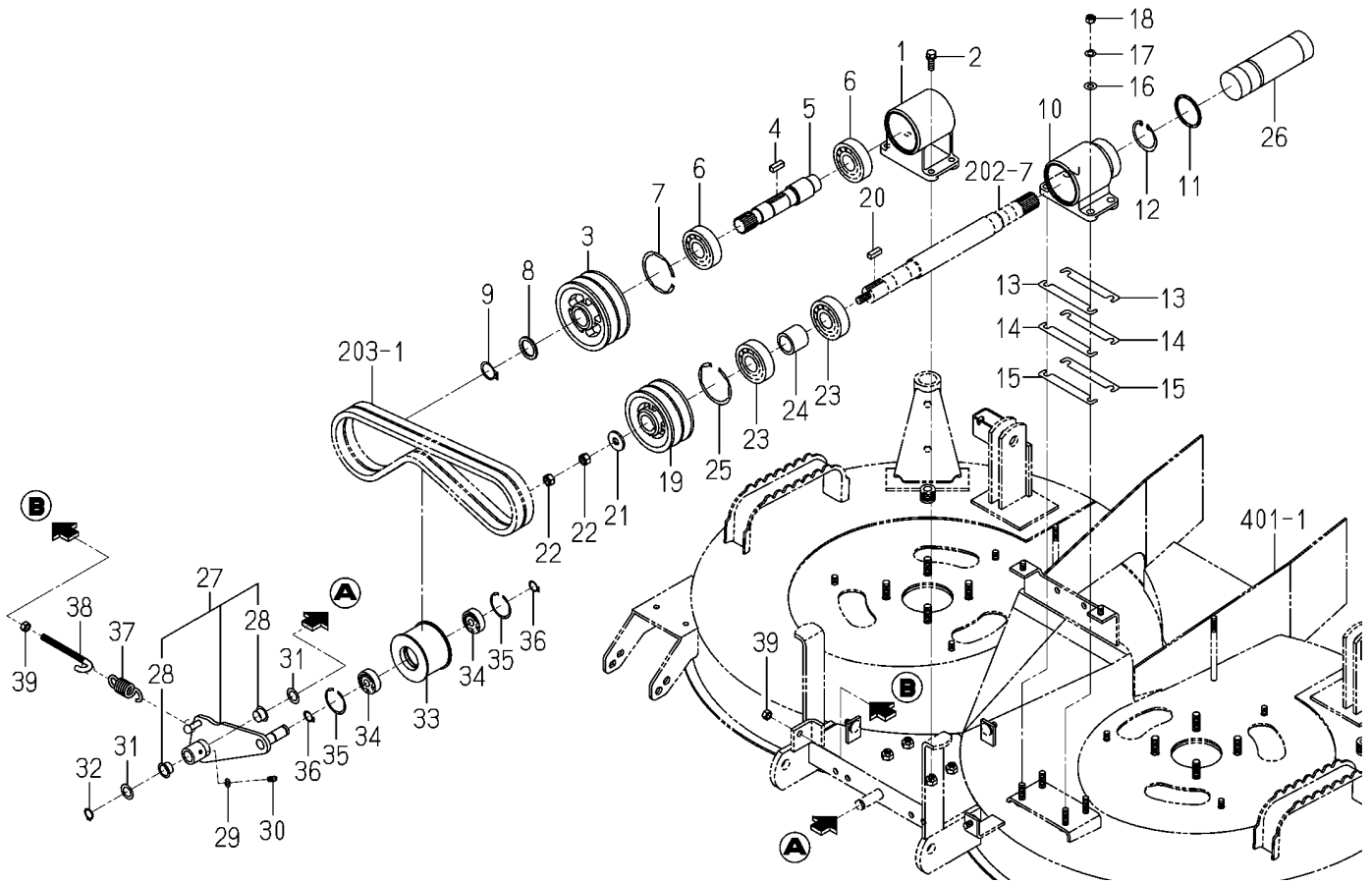


FIG.201 PULLEY SYSTEM



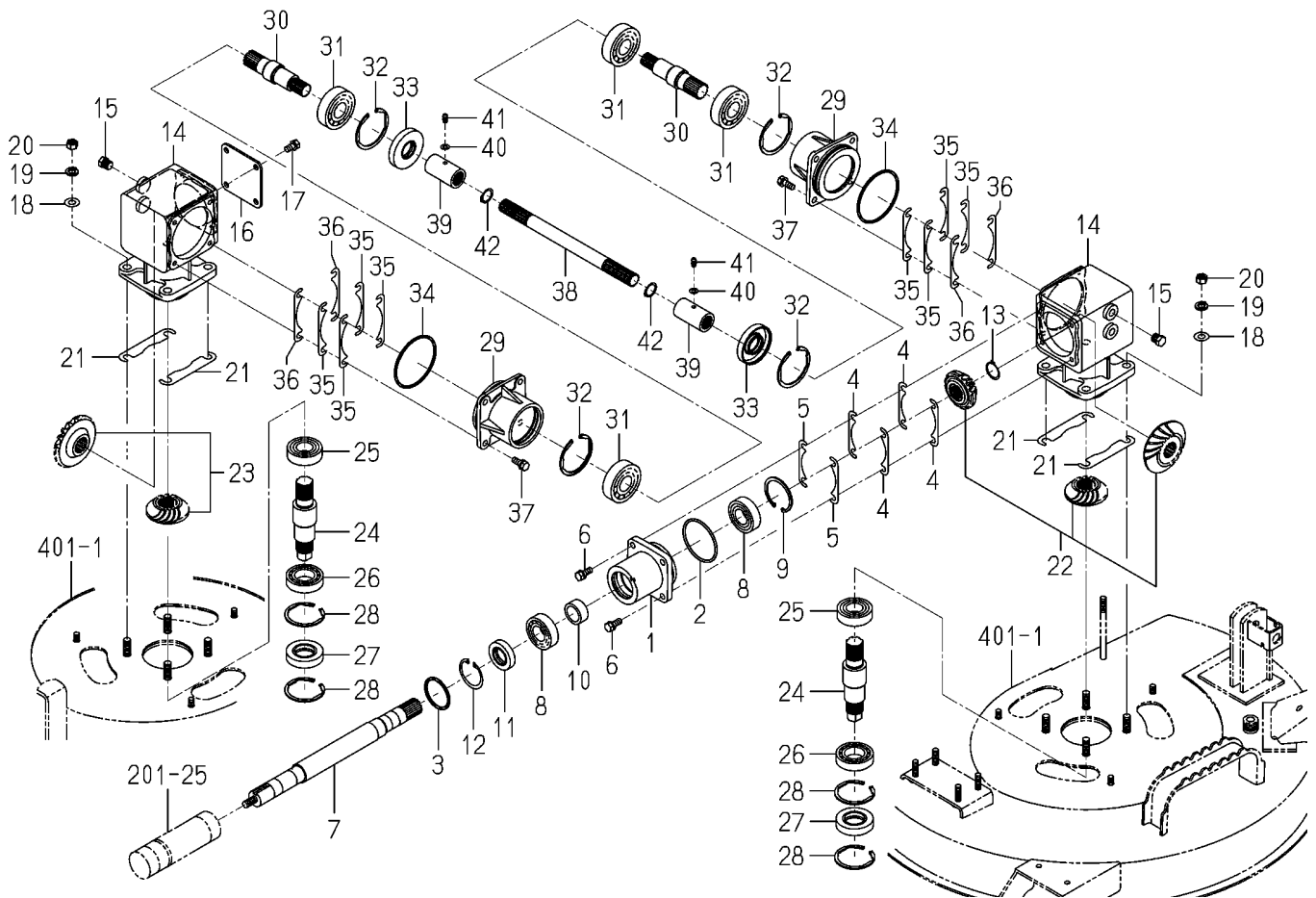
| 図番 | 部品コード           | 品名                  | 仕様 | 型式      |  |  |  |  |  | 代替性 | 色番号 | グループ | 備考 |
|----|-----------------|---------------------|----|---------|--|--|--|--|--|-----|-----|------|----|
|    |                 |                     |    | SCM B48 |  |  |  |  |  |     |     |      |    |
| 1  | 8674-201-001-00 | METAL/INPUT         | *  | 1       |  |  |  |  |  |     |     |      |    |
| 2  | V211-560-802-50 | BOLT, SEMS/M8X25 7T | *  | 4       |  |  |  |  |  |     |     |      |    |
| 3  | 8663-201-053-00 | PULLEY/V2B102       | *  | 1       |  |  |  |  |  |     |     |      |    |
| 4  | 8663-201-054-00 | KEY/07X07X22        | *  | 1       |  |  |  |  |  |     |     |      |    |
| 5  | 8674-201-002-00 | SHAFT/INPUT         | *  | 1       |  |  |  |  |  |     |     |      |    |
| 6  | V600-150-630-50 | BEARING, RB/6305SS  | *  | 2       |  |  |  |  |  |     |     |      |    |
| 7  | V707-140-062-00 | RING/SNAP           | *  | 1       |  |  |  |  |  |     |     |      |    |
| 8  | 1415-216-602-00 | WASHER/26X35X2      | *  | 1       |  |  |  |  |  |     |     |      |    |
| 9  | V704-140-025-00 | RING, SNAP/25 C     | *  | 1       |  |  |  |  |  |     |     |      |    |
| 10 | 8674-201-003-10 | METAL/PULLEY        | *  | 1       |  |  |  |  |  |     |     |      |    |
| 11 | V720-103-504-40 | O-RING/P44          | *  | 1       |  |  |  |  |  |     |     |      |    |
| 12 | V705-140-045-00 | RING, SNAP/45 C     | *  | 1       |  |  |  |  |  |     |     |      |    |
| 13 | 8674-201-007-00 | SHIM/0.2            | *  | 2       |  |  |  |  |  |     |     |      |    |
| 14 | 8663-201-066-00 | SHIM/0.5            | *  | 2       |  |  |  |  |  |     |     |      |    |
| 15 | 8663-201-068-00 | SHIM/1.0            | *  | 2       |  |  |  |  |  |     |     |      |    |
| 16 | V411-260-008-00 | WASHER, PL/M 8      | *  | 4       |  |  |  |  |  |     |     |      |    |
| 17 | V401-160-008-00 | WASHER, SP/M 8      | *  | 4       |  |  |  |  |  |     |     |      |    |
| 18 | V304-260-008-00 | NUT                 | *  | 4       |  |  |  |  |  |     |     |      |    |
| 19 | 8663-201-057-10 | PULLEY/V2B90        | *  | 1       |  |  |  |  |  |     |     |      |    |
| 20 | 8663-201-054-00 | KEY/07X07X22        | *  | 1       |  |  |  |  |  |     |     |      |    |
| 21 | 8663-201-063-00 | WASHER/11X30X03     | *  | 1       |  |  |  |  |  |     |     |      |    |
| 22 | V304-260-010-00 | NUT                 | *  | 2       |  |  |  |  |  |     |     |      |    |
| 23 | V600-150-630-50 | BEARING, RB/6305SS  | *  | 2       |  |  |  |  |  |     |     |      |    |
| 24 | 8674-201-004-00 | COLLAR/25X34X30     | *  | 1       |  |  |  |  |  |     |     |      |    |
| 25 | V707-140-062-00 | RING/SNAP           | *  | 1       |  |  |  |  |  |     |     |      |    |
| 26 | 8674-201-005-10 | TUBE/148            | *  | 1       |  |  |  |  |  |     |     |      |    |
| 27 | 8663-201-510-50 | ARM/TENSION ASSY    | *  | 1       |  |  |  |  |  |     |     |      |    |
| 28 | 2502-407-001-10 | BUSH/15X17X11       | *  | 2       |  |  |  |  |  |     |     |      |    |
| 29 | V401-160-006-00 | WASHER, SP/M 6      | *  | 1       |  |  |  |  |  |     |     |      |    |
| 30 | V760-150-000-00 | NIPPLE, GREASE      | *  | 1       |  |  |  |  |  |     |     |      |    |

FIG.201 PULLEY SYSTEM



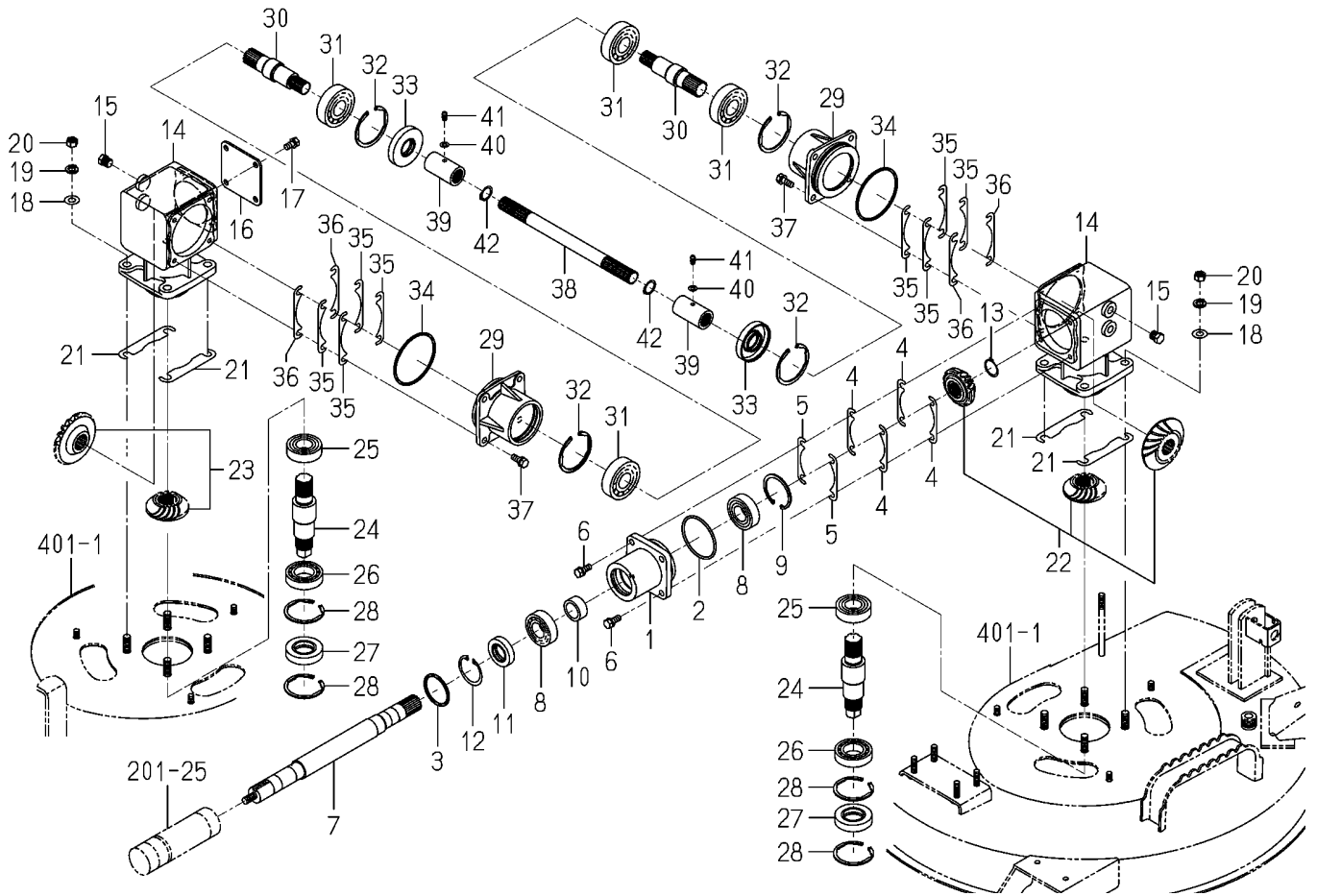
| 図番 | 部品コード           | 品名                 | 仕様 | 型式         |  |  |  |  |  | 代替性 | 色番号 | グループ | 備考 |
|----|-----------------|--------------------|----|------------|--|--|--|--|--|-----|-----|------|----|
|    |                 |                    |    | SCM<br>B48 |  |  |  |  |  |     |     |      |    |
| 31 | 3517-205-007-00 | WASHER             | *  | 2          |  |  |  |  |  |     |     |      |    |
| 32 | V704-140-015-00 | RING, SNAP/15 C    | *  | 1          |  |  |  |  |  |     |     |      |    |
| 33 | 8674-201-006-00 | PULLEY/FT070X044   | *  | 1          |  |  |  |  |  |     |     |      |    |
| 34 | V600-350-620-20 | BEARING, RB/6202RS | *  | 2          |  |  |  |  |  |     |     |      |    |
| 35 | V705-140-035-00 | RING, CIRCLIP      | *  | 2          |  |  |  |  |  |     |     |      |    |
| 36 | V704-140-015-00 | RING, SNAP/15 C    | *  | 2          |  |  |  |  |  |     |     |      |    |
| 37 | 1337-401-006-00 | SPRING             | *  | 1          |  |  |  |  |  |     |     |      |    |
| 38 | 3737-341-007-00 | ROD, CHAIN TENSION | *  | 1          |  |  |  |  |  |     |     |      |    |
| 39 | V304-260-008-00 | NUT                | *  | 2          |  |  |  |  |  |     |     |      |    |
|    |                 |                    |    |            |  |  |  |  |  |     |     |      |    |
|    |                 |                    |    |            |  |  |  |  |  |     |     |      |    |
|    |                 |                    |    |            |  |  |  |  |  |     |     |      |    |
|    |                 |                    |    |            |  |  |  |  |  |     |     |      |    |
|    |                 |                    |    |            |  |  |  |  |  |     |     |      |    |
|    |                 |                    |    |            |  |  |  |  |  |     |     |      |    |
|    |                 |                    |    |            |  |  |  |  |  |     |     |      |    |
|    |                 |                    |    |            |  |  |  |  |  |     |     |      |    |
|    |                 |                    |    |            |  |  |  |  |  |     |     |      |    |
|    |                 |                    |    |            |  |  |  |  |  |     |     |      |    |
|    |                 |                    |    |            |  |  |  |  |  |     |     |      |    |
|    |                 |                    |    |            |  |  |  |  |  |     |     |      |    |
|    |                 |                    |    |            |  |  |  |  |  |     |     |      |    |

FIG.202 CASE(BEVEL)SYSTEM



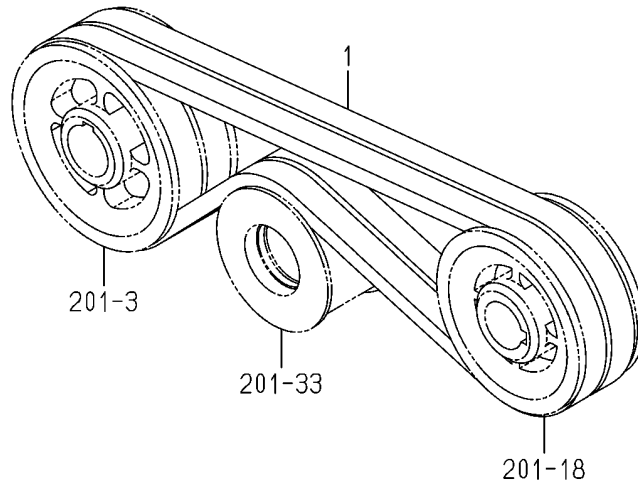
| 図番 | 部品コード           | 品名                   | 仕様 | 型式      |  |  |  |  | 代替性 | 色番号 | グループ | 備考 |
|----|-----------------|----------------------|----|---------|--|--|--|--|-----|-----|------|----|
|    |                 |                      |    | SCM B48 |  |  |  |  |     |     |      |    |
| 1  | 8674-202-001-20 | METAL/CASE           | *  | 1       |  |  |  |  |     |     |      |    |
| 2  | V721-103-106-50 | O-RING/G65           | *  | 1       |  |  |  |  |     |     |      |    |
| 3  | V720-103-504-40 | O-RING/P44           | *  | 1       |  |  |  |  |     |     |      |    |
| 4  | 8663-202-055-00 | SHIM/0.1             | *  | 4       |  |  |  |  |     |     |      |    |
| 5  | 8663-202-056-00 | SHIM/0.2             | *  | 2       |  |  |  |  |     |     |      |    |
| 6  | V211-560-802-00 | BOLT/M8X20           | *  | 4       |  |  |  |  |     |     |      |    |
| 7  | 8674-202-002-00 | SHAFT/LH             | *  | 1       |  |  |  |  |     |     |      |    |
| 8  | 1594-221-001-00 | BEARING/BALL 6205SH2 | *  | 2       |  |  |  |  |     |     |      |    |
| 9  | V705-140-052-00 | RING, SNAP/52 C      | *  | 1       |  |  |  |  |     |     |      |    |
| 10 | 8674-202-003-00 | COLLAR/25X34X15      | *  | 1       |  |  |  |  |     |     |      |    |
| 11 | V744-128-451-10 | SEAL, OIL/TC284511   | *  | 1       |  |  |  |  |     |     |      |    |
| 12 | V705-140-045-00 | RING, SNAP/45 C      | *  | 1       |  |  |  |  |     |     |      |    |
| 13 | V704-140-025-00 | RING, SNAP/25 C      | *  | 1       |  |  |  |  |     |     |      |    |
| 14 | 8674-202-004-00 | CASE/BEVEL           | *  | 2       |  |  |  |  |     |     |      |    |
| 15 | 7955-201-026-00 | PLUG, DRAIN (1/4)    | *  | 4       |  |  |  |  |     |     |      |    |
| 16 | 8674-202-006-00 | COVER/CASE           | *  | 1       |  |  |  |  |     |     |      |    |
| 17 | V211-260-801-60 | BOLT, SEMS (S) M8X16 | *  | 4       |  |  |  |  |     |     |      |    |
| 18 | V411-260-010-00 | WASHER/M10           | *  | 8       |  |  |  |  |     |     |      |    |
| 19 | V401-160-010-00 | WASHER, SP/M10       | *  | 8       |  |  |  |  |     |     |      |    |
| 20 | V304-260-010-00 | NUT                  | *  | 8       |  |  |  |  |     |     |      |    |
| 21 | 8670-201-005-10 | SHIM/0.2             | *  | 4       |  |  |  |  |     |     |      |    |
| 22 | 8674-202-210-00 | GEAR/B/21-25-21 SET  | *  | 1       |  |  |  |  |     |     |      |    |
| 23 | 8674-202-220-00 | GEAR/BEVEL/25-2 SET  | *  | 1       |  |  |  |  |     |     |      |    |
| 24 | 8674-202-007-00 | SHAFT/BLADE          | *  | 2       |  |  |  |  |     |     |      |    |
| 25 | 1594-221-001-00 | BEARING/BALL 6205SH2 | *  | 2       |  |  |  |  |     |     |      |    |
| 26 | V600-110-600-60 | BEARING, RB 6006     | *  | 2       |  |  |  |  |     |     |      |    |
| 27 | V744-130-551-20 | SEAL, OIL/TC305512   | *  | 2       |  |  |  |  |     |     |      |    |
| 28 | V707-140-055-00 | RING/SNAP            | *  | 4       |  |  |  |  |     |     |      |    |
| 29 | 8667-201-002-00 | METAL/INPUT          | *  | 2       |  |  |  |  |     |     |      |    |
| 30 | 8674-202-009-00 | SHAFT/CASE           | *  | 2       |  |  |  |  |     |     |      |    |

FIG.202 CASE(BEVEL)SYSTEM



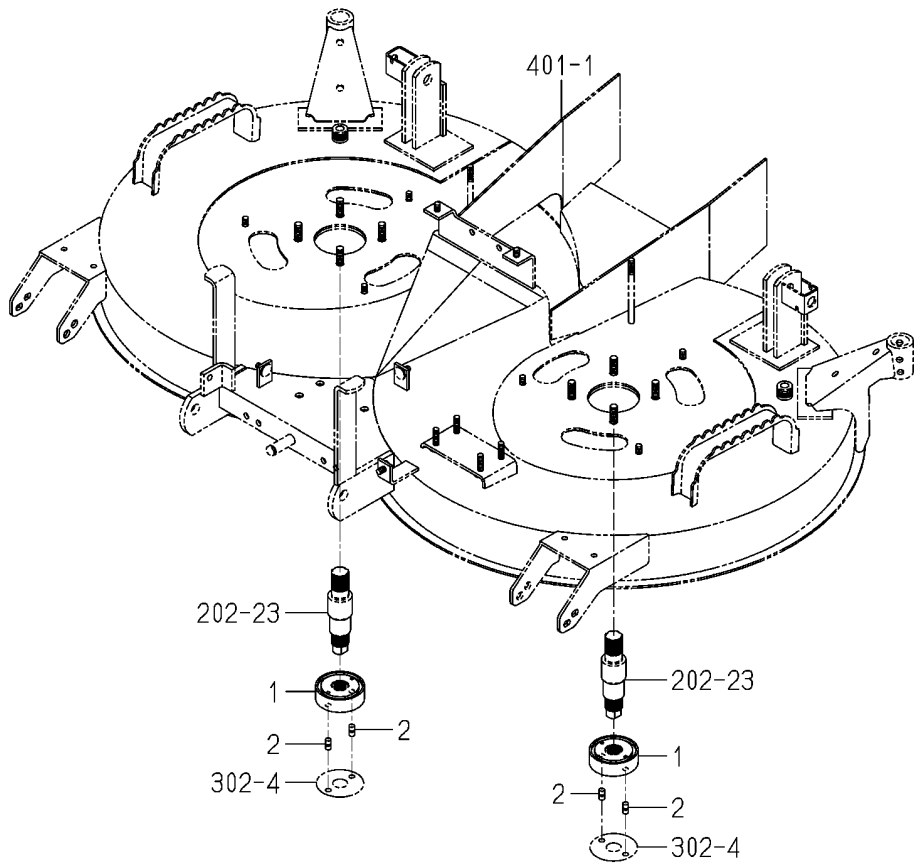
| 図番 | 部品コード           | 品名                   | 仕様 | 型式      |  |  |  |  |  | 代替性 | 色番号 | グループ | 備考 |
|----|-----------------|----------------------|----|---------|--|--|--|--|--|-----|-----|------|----|
|    |                 |                      |    | SCM B48 |  |  |  |  |  |     |     |      |    |
| 31 | 1594-218-001-00 | BEARING/BALL 6305SH2 | *  | 4       |  |  |  |  |  |     |     |      |    |
| 32 | V707-140-062-00 | RING/SNAP            | *  | 4       |  |  |  |  |  |     |     |      |    |
| 33 | 8595-201-025-00 | SEAL/OIL             | *  | 2       |  |  |  |  |  |     |     |      |    |
| 34 | V721-103-108-00 | O-RING/G80           | *  | 2       |  |  |  |  |  |     |     |      |    |
| 35 | 8595-201-021-00 | SHIM/0.1             | *  | 8       |  |  |  |  |  |     |     |      |    |
| 36 | 8595-201-022-00 | SHIM/0.2             | *  | 4       |  |  |  |  |  |     |     |      |    |
| 37 | V211-560-802-00 | BOLT/M8X20           | *  | 8       |  |  |  |  |  |     |     |      |    |
| 38 | 8674-202-011-10 | SHAFT/JOINT          | *  | 1       |  |  |  |  |  |     |     |      |    |
| 39 | 1782-122-051-00 | COUPLING/18X30X55    | *  | 2       |  |  |  |  |  |     |     |      |    |
| 40 | V411-260-006-00 | WASHER / M6          | *  | 2       |  |  |  |  |  |     |     |      |    |
| 41 | V760-150-000-00 | NIPPLE, GREASE       | *  | 2       |  |  |  |  |  |     |     |      |    |
| 42 | 8674-202-012-00 | RING/SNAP/CS20       | *  | 2       |  |  |  |  |  |     |     |      |    |
|    |                 |                      |    |         |  |  |  |  |  |     |     |      |    |
|    |                 |                      |    |         |  |  |  |  |  |     |     |      |    |
|    |                 |                      |    |         |  |  |  |  |  |     |     |      |    |
|    |                 |                      |    |         |  |  |  |  |  |     |     |      |    |
|    |                 |                      |    |         |  |  |  |  |  |     |     |      |    |
|    |                 |                      |    |         |  |  |  |  |  |     |     |      |    |
|    |                 |                      |    |         |  |  |  |  |  |     |     |      |    |
|    |                 |                      |    |         |  |  |  |  |  |     |     |      |    |
|    |                 |                      |    |         |  |  |  |  |  |     |     |      |    |
|    |                 |                      |    |         |  |  |  |  |  |     |     |      |    |
|    |                 |                      |    |         |  |  |  |  |  |     |     |      |    |
|    |                 |                      |    |         |  |  |  |  |  |     |     |      |    |
|    |                 |                      |    |         |  |  |  |  |  |     |     |      |    |
|    |                 |                      |    |         |  |  |  |  |  |     |     |      |    |

FIG.203 BELT SYSTEM



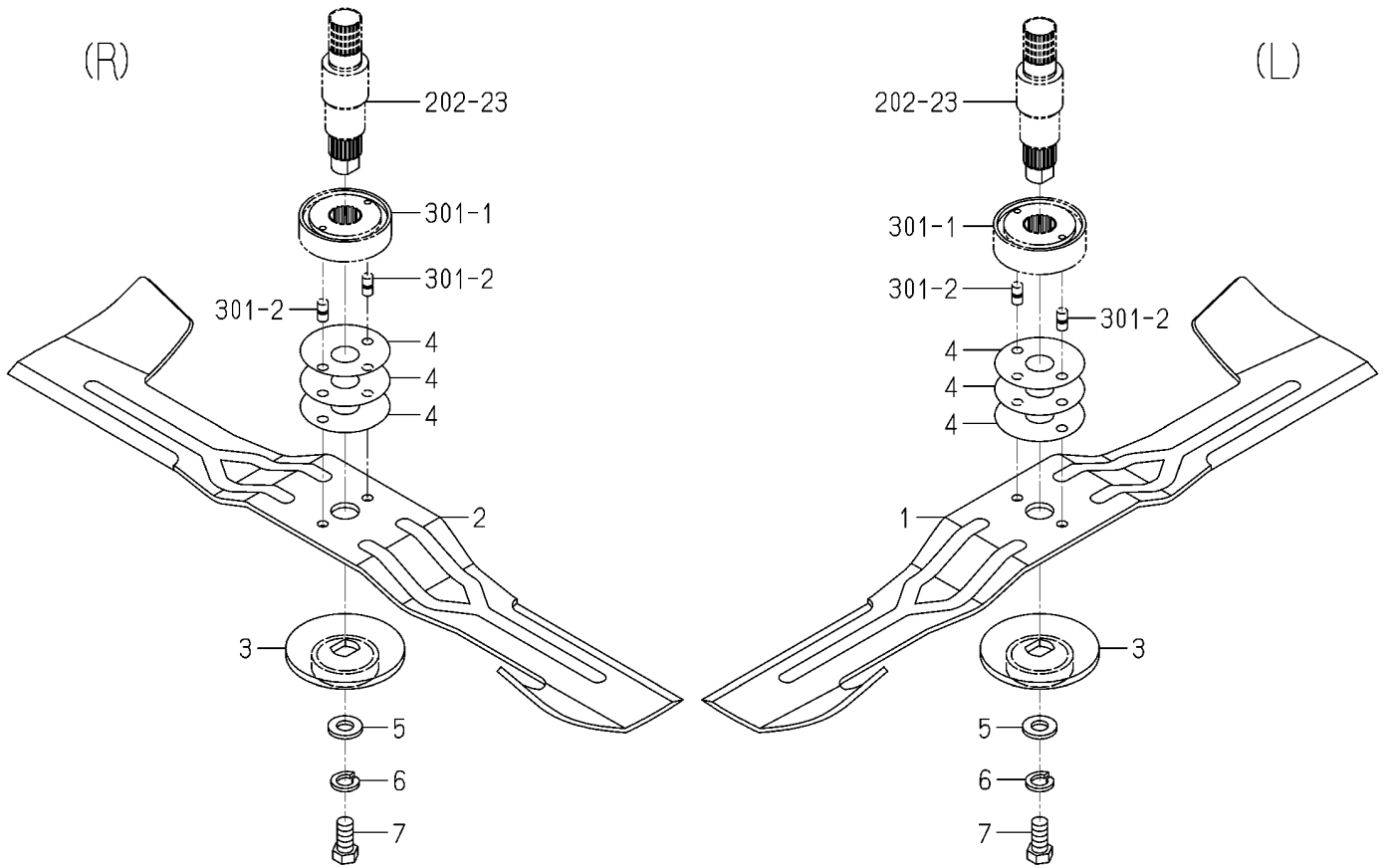
| 図番 | 部品コード           | 品名                | 仕様 | 型式         |  |  |  |  | 代替性 | 色番号 | グループ | 備考 |
|----|-----------------|-------------------|----|------------|--|--|--|--|-----|-----|------|----|
|    |                 |                   |    | SCM<br>B48 |  |  |  |  |     |     |      |    |
| 1  | 8674-203-200-00 | BELT/VCOGB035 SET | *  | 1          |  |  |  |  |     |     |      |    |
|    |                 |                   |    |            |  |  |  |  |     |     |      |    |
|    |                 |                   |    |            |  |  |  |  |     |     |      |    |
|    |                 |                   |    |            |  |  |  |  |     |     |      |    |
|    |                 |                   |    |            |  |  |  |  |     |     |      |    |
|    |                 |                   |    |            |  |  |  |  |     |     |      |    |
|    |                 |                   |    |            |  |  |  |  |     |     |      |    |
|    |                 |                   |    |            |  |  |  |  |     |     |      |    |
|    |                 |                   |    |            |  |  |  |  |     |     |      |    |
|    |                 |                   |    |            |  |  |  |  |     |     |      |    |
|    |                 |                   |    |            |  |  |  |  |     |     |      |    |
|    |                 |                   |    |            |  |  |  |  |     |     |      |    |
|    |                 |                   |    |            |  |  |  |  |     |     |      |    |
|    |                 |                   |    |            |  |  |  |  |     |     |      |    |
|    |                 |                   |    |            |  |  |  |  |     |     |      |    |
|    |                 |                   |    |            |  |  |  |  |     |     |      |    |
|    |                 |                   |    |            |  |  |  |  |     |     |      |    |
|    |                 |                   |    |            |  |  |  |  |     |     |      |    |
|    |                 |                   |    |            |  |  |  |  |     |     |      |    |
|    |                 |                   |    |            |  |  |  |  |     |     |      |    |
|    |                 |                   |    |            |  |  |  |  |     |     |      |    |
|    |                 |                   |    |            |  |  |  |  |     |     |      |    |
|    |                 |                   |    |            |  |  |  |  |     |     |      |    |
|    |                 |                   |    |            |  |  |  |  |     |     |      |    |
|    |                 |                   |    |            |  |  |  |  |     |     |      |    |
|    |                 |                   |    |            |  |  |  |  |     |     |      |    |
|    |                 |                   |    |            |  |  |  |  |     |     |      |    |
|    |                 |                   |    |            |  |  |  |  |     |     |      |    |

FIG.301 COLLAR(BLADE)SYSTEM



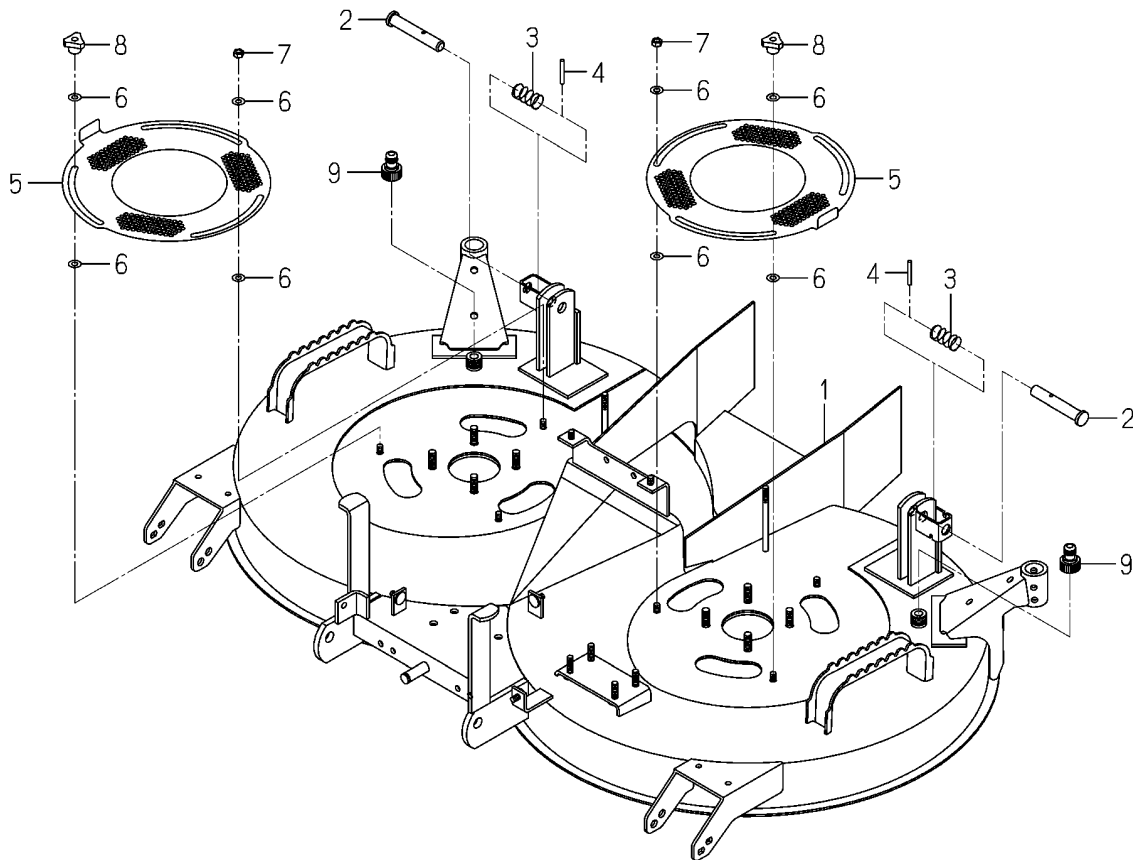
| 図番 | 部品コード           | 品名           | 仕様 | 型式      |  |  |  |  | 代替性 | 色番号 | グループ | 備考 |
|----|-----------------|--------------|----|---------|--|--|--|--|-----|-----|------|----|
|    |                 |              |    | SCM B48 |  |  |  |  |     |     |      |    |
| 1  | 8674-301-001-00 | COLLAR/BLADE | *  | 2       |  |  |  |  |     |     |      |    |
| 2  | 8670-301-002-10 | PIN/08X16    | *  | 4       |  |  |  |  |     |     |      |    |
|    |                 |              |    |         |  |  |  |  |     |     |      |    |
|    |                 |              |    |         |  |  |  |  |     |     |      |    |
|    |                 |              |    |         |  |  |  |  |     |     |      |    |
|    |                 |              |    |         |  |  |  |  |     |     |      |    |
|    |                 |              |    |         |  |  |  |  |     |     |      |    |
|    |                 |              |    |         |  |  |  |  |     |     |      |    |
|    |                 |              |    |         |  |  |  |  |     |     |      |    |
|    |                 |              |    |         |  |  |  |  |     |     |      |    |
|    |                 |              |    |         |  |  |  |  |     |     |      |    |
|    |                 |              |    |         |  |  |  |  |     |     |      |    |
|    |                 |              |    |         |  |  |  |  |     |     |      |    |
|    |                 |              |    |         |  |  |  |  |     |     |      |    |
|    |                 |              |    |         |  |  |  |  |     |     |      |    |
|    |                 |              |    |         |  |  |  |  |     |     |      |    |
|    |                 |              |    |         |  |  |  |  |     |     |      |    |
|    |                 |              |    |         |  |  |  |  |     |     |      |    |
|    |                 |              |    |         |  |  |  |  |     |     |      |    |

FIG.302 BLADE SYSTEM



| 図番 | 部品コード           | 品名               | 仕様 | 型式         |  |  |  |  |  | 代替性 | 色番号 | グループ | 備考 |
|----|-----------------|------------------|----|------------|--|--|--|--|--|-----|-----|------|----|
|    |                 |                  |    | SCM B48    |  |  |  |  |  |     |     |      |    |
| 1  | 8674-306-001-00 | BLADE/60X666/A   | *  | 1<br>-1373 |  |  |  |  |  |     |     |      |    |
| 1  | 8674-306-001-10 | BLADE/60X666/A   | *  | 1<br>1374- |  |  |  |  |  |     |     |      |    |
| 2  | 8674-306-002-00 | BLADE/60X666/B   | *  | 1<br>-1373 |  |  |  |  |  |     |     |      |    |
| 2  | 8674-306-002-10 | BLADE/60X666/B   | *  | 1<br>1374- |  |  |  |  |  |     |     |      |    |
| 3  | 8674-306-210-00 | PLATE/BLADE COMP | *  | 2          |  |  |  |  |  |     |     |      |    |
| 4  | 8674-306-003-00 | SHIM/1.2         | *  | 6          |  |  |  |  |  |     |     |      |    |
| 5  | 8674-306-004-00 | WASHER/11X22X03  | *  | 2          |  |  |  |  |  |     |     |      |    |
| 6  | V401-160-012-00 | WASHER, SP/M12   | *  | 2          |  |  |  |  |  |     |     |      |    |
| 7  | V203-361-202-50 | BOLT/M12X25 7T   | *  | 2          |  |  |  |  |  |     |     |      |    |
|    |                 |                  |    |            |  |  |  |  |  |     |     |      |    |
|    |                 |                  |    |            |  |  |  |  |  |     |     |      |    |
|    |                 |                  |    |            |  |  |  |  |  |     |     |      |    |
|    |                 |                  |    |            |  |  |  |  |  |     |     |      |    |
|    |                 |                  |    |            |  |  |  |  |  |     |     |      |    |
|    |                 |                  |    |            |  |  |  |  |  |     |     |      |    |
|    |                 |                  |    |            |  |  |  |  |  |     |     |      |    |
|    |                 |                  |    |            |  |  |  |  |  |     |     |      |    |
|    |                 |                  |    |            |  |  |  |  |  |     |     |      |    |
|    |                 |                  |    |            |  |  |  |  |  |     |     |      |    |
|    |                 |                  |    |            |  |  |  |  |  |     |     |      |    |
|    |                 |                  |    |            |  |  |  |  |  |     |     |      |    |
|    |                 |                  |    |            |  |  |  |  |  |     |     |      |    |
|    |                 |                  |    |            |  |  |  |  |  |     |     |      |    |
|    |                 |                  |    |            |  |  |  |  |  |     |     |      |    |

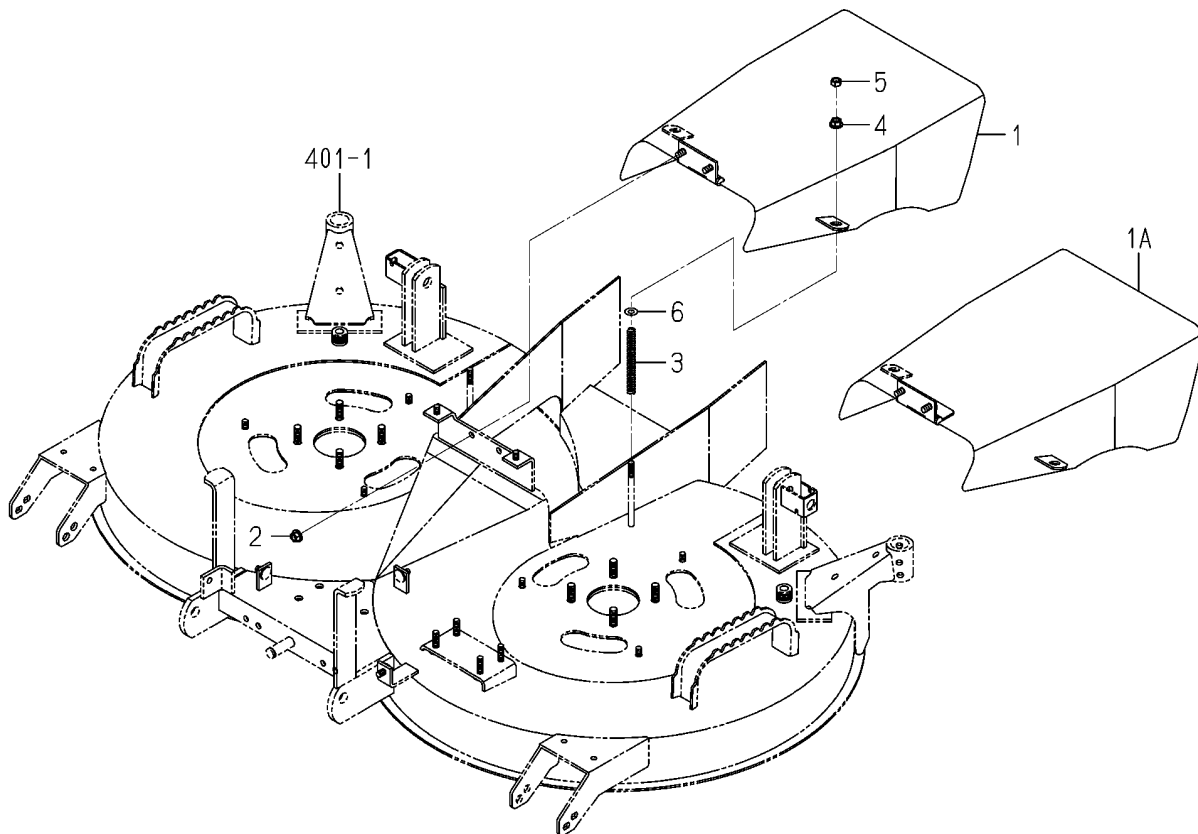
FIG.401 DECK(MOWER)SYSTEM



| 図番 | 部品コード           | 品名                  | 仕様 | 型式      |  |  |  |  |  |  | 代替性 | 色番号 | グループ | 備考 |
|----|-----------------|---------------------|----|---------|--|--|--|--|--|--|-----|-----|------|----|
|    |                 |                     |    | SCM B48 |  |  |  |  |  |  |     |     |      |    |
| 1  | 8674-402-210-00 | DECK/MOWER/48 COMP  | *  | 1       |  |  |  |  |  |  | 7F  |     |      |    |
| 2  | 8595-608-082-10 | PIN/16X96           | *  | 2       |  |  |  |  |  |  |     |     |      |    |
| 3  | 1560-601-028-00 | SPRING/HCO42        | *  | 2       |  |  |  |  |  |  |     |     |      |    |
| 4  | V580-140-504-00 | PIN, SPRING/5 X40 W | *  | 2       |  |  |  |  |  |  |     |     |      |    |
| 5  | 8674-402-001-00 | COVER/METAL         | *  | 2       |  |  |  |  |  |  |     |     |      |    |
| 6  | V411-260-008-00 | WASHER, PL/M 8      | *  | 12      |  |  |  |  |  |  |     |     |      |    |
| 7  | 1719-312-001-00 | U-NUT               | *  | 4       |  |  |  |  |  |  |     |     |      |    |
| 8  | 3256-702-002-00 | NUT, KNOB           | *  | 2       |  |  |  |  |  |  |     |     |      |    |
| 9  | 8663-402-002-10 | PLUG/HOSE           | *  | 2       |  |  |  |  |  |  |     |     |      |    |
|    |                 |                     |    |         |  |  |  |  |  |  |     |     |      |    |
|    |                 |                     |    |         |  |  |  |  |  |  |     |     |      |    |
|    |                 |                     |    |         |  |  |  |  |  |  |     |     |      |    |
|    |                 |                     |    |         |  |  |  |  |  |  |     |     |      |    |
|    |                 |                     |    |         |  |  |  |  |  |  |     |     |      |    |
|    |                 |                     |    |         |  |  |  |  |  |  |     |     |      |    |
|    |                 |                     |    |         |  |  |  |  |  |  |     |     |      |    |
|    |                 |                     |    |         |  |  |  |  |  |  |     |     |      |    |
|    |                 |                     |    |         |  |  |  |  |  |  |     |     |      |    |
|    |                 |                     |    |         |  |  |  |  |  |  |     |     |      |    |
|    |                 |                     |    |         |  |  |  |  |  |  |     |     |      |    |
|    |                 |                     |    |         |  |  |  |  |  |  |     |     |      |    |
|    |                 |                     |    |         |  |  |  |  |  |  |     |     |      |    |
|    |                 |                     |    |         |  |  |  |  |  |  |     |     |      |    |
|    |                 |                     |    |         |  |  |  |  |  |  |     |     |      |    |
|    |                 |                     |    |         |  |  |  |  |  |  |     |     |      |    |
|    |                 |                     |    |         |  |  |  |  |  |  |     |     |      |    |
|    |                 |                     |    |         |  |  |  |  |  |  |     |     |      |    |
|    |                 |                     |    |         |  |  |  |  |  |  |     |     |      |    |
|    |                 |                     |    |         |  |  |  |  |  |  |     |     |      |    |

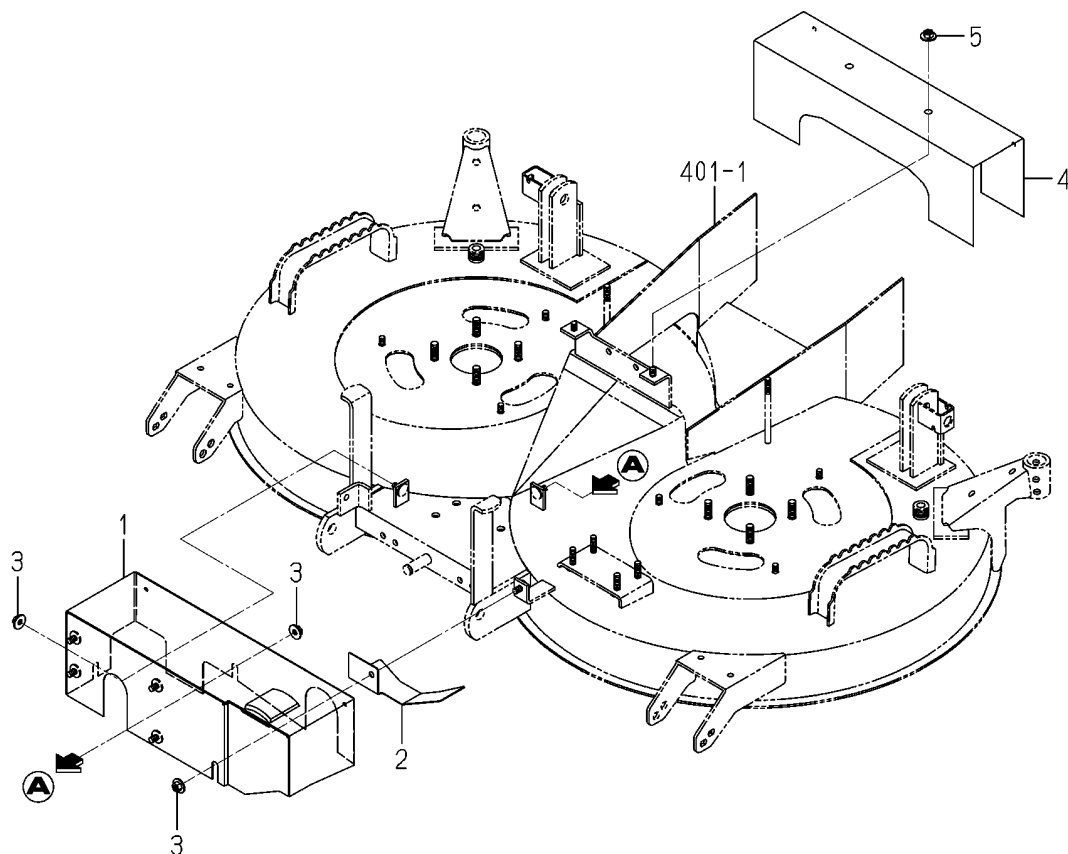


FIG.402 COVER(DISCHARGE)SYSTEM



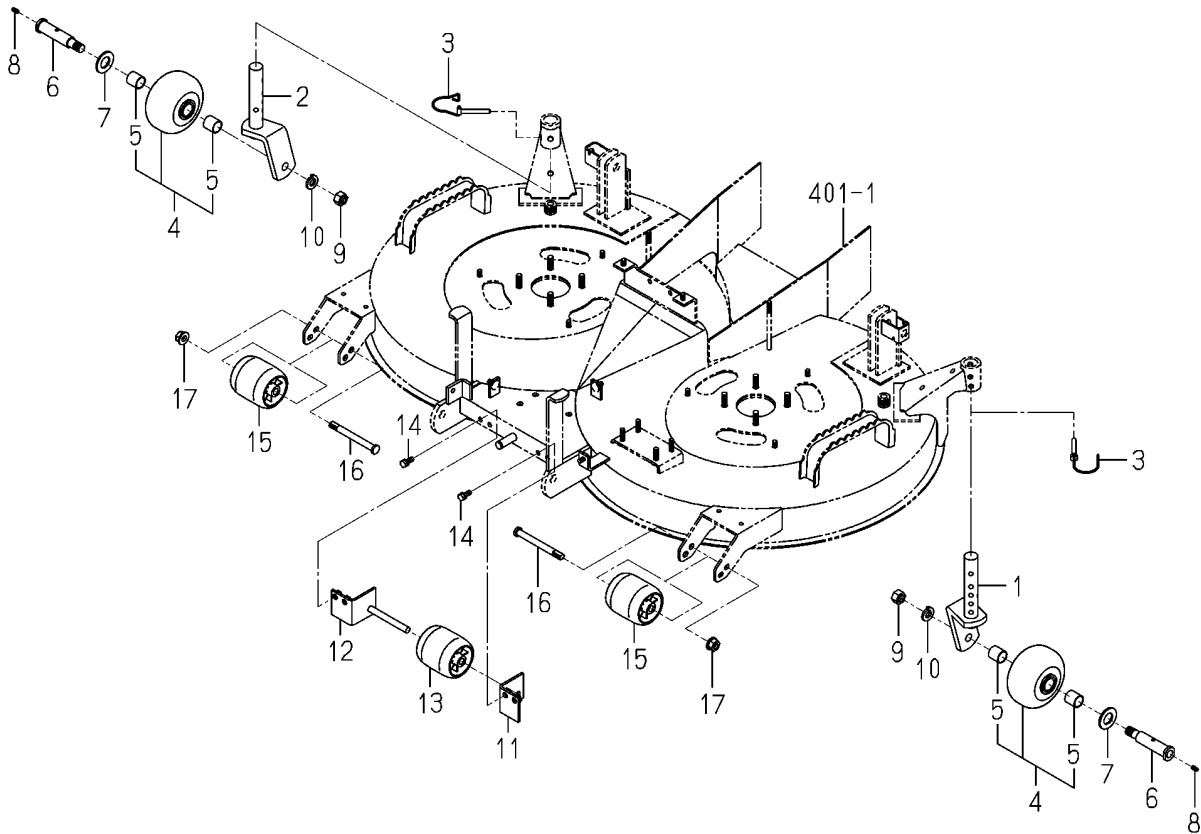
| 図番 | 部品コード           | 品名                | 仕様 | 型式         |  |  |  |  | 代替性 | 色番号 | グループ | 備考 |
|----|-----------------|-------------------|----|------------|--|--|--|--|-----|-----|------|----|
|    |                 |                   |    | SCM<br>B48 |  |  |  |  |     |     |      |    |
| 1  | 8663-406-510-00 | COVER/DISCHARGE/B | *  | 1          |  |  |  |  |     | 7F  |      |    |
| 1A |                 | BLANK             |    |            |  |  |  |  |     | 7F  |      |    |
| 2  | V363-260-008-00 | NUT/WASHER        | *  | 2          |  |  |  |  |     |     |      |    |
| 3  | 8663-406-001-00 | SPRING/HC110      | *  | 2          |  |  |  |  |     |     |      |    |
| 4  | V363-260-008-00 | NUT/WASHER        | *  | 2          |  |  |  |  |     |     |      |    |
| 5  | V304-260-008-00 | NUT               | *  | 2          |  |  |  |  |     |     |      |    |
| 6  | V411-260-008-00 | WASHER, PL/M 8    | *  | 2          |  |  |  |  |     |     |      |    |
|    |                 |                   |    |            |  |  |  |  |     |     |      |    |
|    |                 |                   |    |            |  |  |  |  |     |     |      |    |
|    |                 |                   |    |            |  |  |  |  |     |     |      |    |
|    |                 |                   |    |            |  |  |  |  |     |     |      |    |
|    |                 |                   |    |            |  |  |  |  |     |     |      |    |
|    |                 |                   |    |            |  |  |  |  |     |     |      |    |
|    |                 |                   |    |            |  |  |  |  |     |     |      |    |
|    |                 |                   |    |            |  |  |  |  |     |     |      |    |
|    |                 |                   |    |            |  |  |  |  |     |     |      |    |
|    |                 |                   |    |            |  |  |  |  |     |     |      |    |
|    |                 |                   |    |            |  |  |  |  |     |     |      |    |
|    |                 |                   |    |            |  |  |  |  |     |     |      |    |
|    |                 |                   |    |            |  |  |  |  |     |     |      |    |
|    |                 |                   |    |            |  |  |  |  |     |     |      |    |
|    |                 |                   |    |            |  |  |  |  |     |     |      |    |
|    |                 |                   |    |            |  |  |  |  |     |     |      |    |
|    |                 |                   |    |            |  |  |  |  |     |     |      |    |
|    |                 |                   |    |            |  |  |  |  |     |     |      |    |
|    |                 |                   |    |            |  |  |  |  |     |     |      |    |
|    |                 |                   |    |            |  |  |  |  |     |     |      |    |
|    |                 |                   |    |            |  |  |  |  |     |     |      |    |
|    |                 |                   |    |            |  |  |  |  |     |     |      |    |
|    |                 |                   |    |            |  |  |  |  |     |     |      |    |
|    |                 |                   |    |            |  |  |  |  |     |     |      |    |
|    |                 |                   |    |            |  |  |  |  |     |     |      |    |
|    |                 |                   |    |            |  |  |  |  |     |     |      |    |
|    |                 |                   |    |            |  |  |  |  |     |     |      |    |
|    |                 |                   |    |            |  |  |  |  |     |     |      |    |
|    |                 |                   |    |            |  |  |  |  |     |     |      |    |
|    |                 |                   |    |            |  |  |  |  |     |     |      |    |
|    |                 |                   |    |            |  |  |  |  |     |     |      |    |
|    |                 |                   |    |            |  |  |  |  |     |     |      |    |
|    |                 |                   |    |            |  |  |  |  |     |     |      |    |
|    |                 |                   |    |            |  |  |  |  |     |     |      |    |
|    |                 |                   |    |            |  |  |  |  |     |     |      |    |
|    |                 |                   |    |            |  |  |  |  |     |     |      |    |
|    |                 |                   |    |            |  |  |  |  |     |     |      |    |
|    |                 |                   |    |            |  |  |  |  |     |     |      |    |
|    |                 |                   |    |            |  |  |  |  |     |     |      |    |
|    |                 |                   |    |            |  |  |  |  |     |     |      |    |
|    |                 |                   |    |            |  |  |  |  |     |     |      |    |
|    |                 |                   |    |            |  |  |  |  |     |     |      |    |
|    |                 |                   |    |            |  |  |  |  |     |     |      |    |

FIG.403 COVER SYSTEM



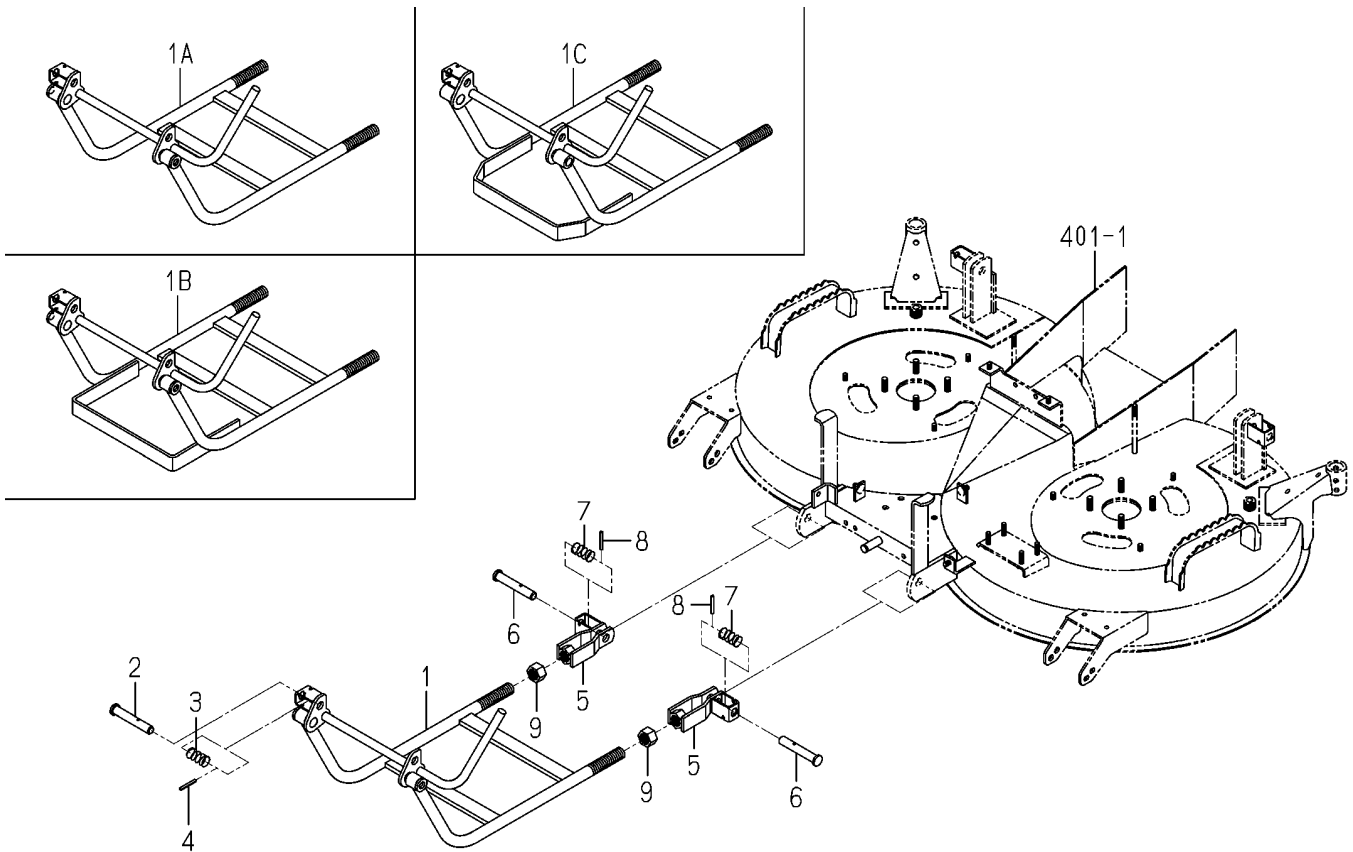
| 図番 | 部品コード           | 品名                | 仕様 | 型式      |  |  |  |  | 代替性 | 色番号 | グループ | 備考 |
|----|-----------------|-------------------|----|---------|--|--|--|--|-----|-----|------|----|
|    |                 |                   |    | SCM B48 |  |  |  |  |     |     |      |    |
| 1  | 8674-407-210-00 | COVER/PULLEY COMP | *  | 1       |  |  |  |  |     | 7F  |      |    |
| 2  | 8674-407-002-00 | COVER/UNDER       | *  | 1       |  |  |  |  |     | 7F  |      |    |
| 3  | V363-260-008-00 | NUT/WASHER        | *  | 3       |  |  |  |  |     |     |      |    |
| 4  | 8674-407-001-00 | COVER/SHAFT       | *  | 1       |  |  |  |  |     | 7F  |      |    |
| 5  | V363-260-008-00 | NUT/WASHER        | *  | 2       |  |  |  |  |     |     |      |    |
|    |                 |                   |    |         |  |  |  |  |     |     |      |    |
|    |                 |                   |    |         |  |  |  |  |     |     |      |    |
|    |                 |                   |    |         |  |  |  |  |     |     |      |    |
|    |                 |                   |    |         |  |  |  |  |     |     |      |    |
|    |                 |                   |    |         |  |  |  |  |     |     |      |    |
|    |                 |                   |    |         |  |  |  |  |     |     |      |    |
|    |                 |                   |    |         |  |  |  |  |     |     |      |    |
|    |                 |                   |    |         |  |  |  |  |     |     |      |    |
|    |                 |                   |    |         |  |  |  |  |     |     |      |    |
|    |                 |                   |    |         |  |  |  |  |     |     |      |    |
|    |                 |                   |    |         |  |  |  |  |     |     |      |    |
|    |                 |                   |    |         |  |  |  |  |     |     |      |    |
|    |                 |                   |    |         |  |  |  |  |     |     |      |    |
|    |                 |                   |    |         |  |  |  |  |     |     |      |    |
|    |                 |                   |    |         |  |  |  |  |     |     |      |    |
|    |                 |                   |    |         |  |  |  |  |     |     |      |    |
|    |                 |                   |    |         |  |  |  |  |     |     |      |    |
|    |                 |                   |    |         |  |  |  |  |     |     |      |    |
|    |                 |                   |    |         |  |  |  |  |     |     |      |    |
|    |                 |                   |    |         |  |  |  |  |     |     |      |    |
|    |                 |                   |    |         |  |  |  |  |     |     |      |    |
|    |                 |                   |    |         |  |  |  |  |     |     |      |    |
|    |                 |                   |    |         |  |  |  |  |     |     |      |    |
|    |                 |                   |    |         |  |  |  |  |     |     |      |    |

FIG.501 WHEEL(GAUGE)SYSTEM



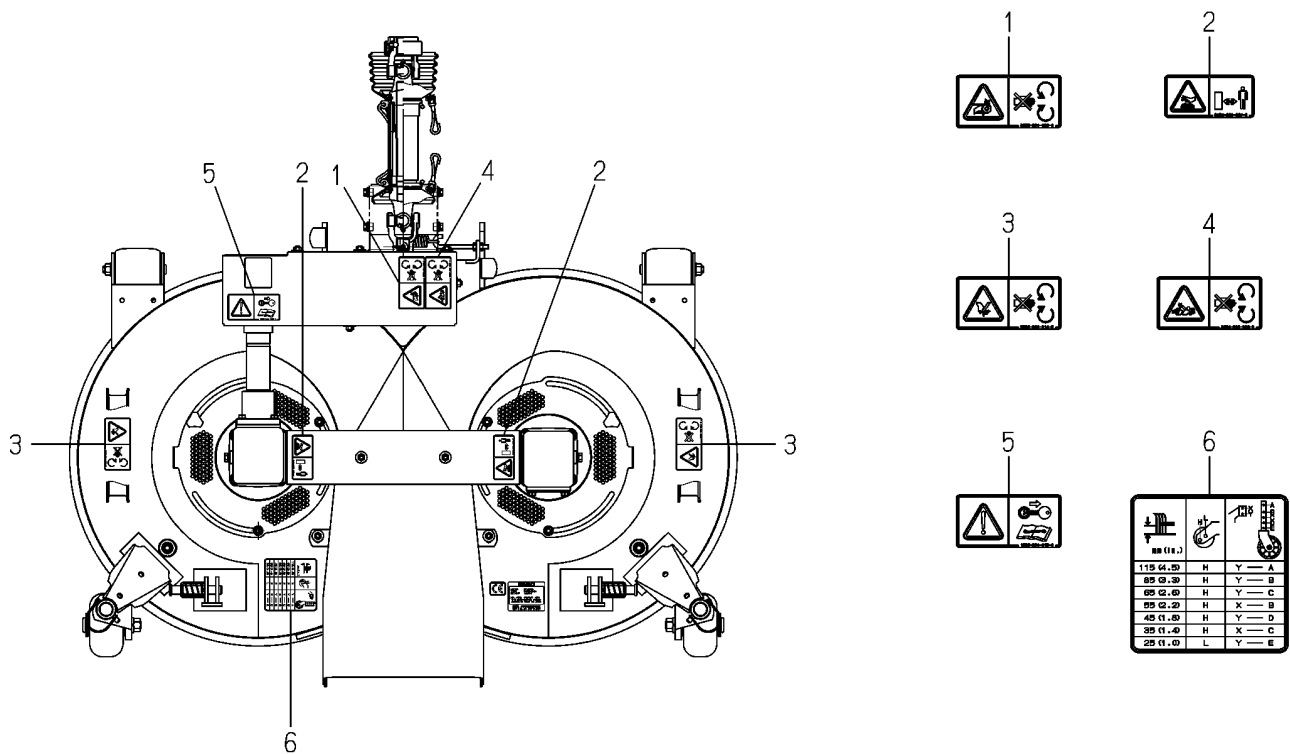
| 図番 | 部品コード           | 品名                 | 仕様 | 型式         |  |  |  |  |  | 代替性 | 色番号   | グループ | 備考 |
|----|-----------------|--------------------|----|------------|--|--|--|--|--|-----|-------|------|----|
|    |                 |                    |    | SCM<br>B48 |  |  |  |  |  |     |       |      |    |
| 1  | 8663-501-210-00 | FORK/WHEEL/LH COMP | *  | 1          |  |  |  |  |  |     |       |      |    |
| 2  | 8663-501-220-00 | FORK/WHEEL/RH COMP | *  | 1          |  |  |  |  |  |     |       |      |    |
| 3  | 8663-501-240-00 | PIN/08X60 COMP     | *  | 2          |  |  |  |  |  |     |       |      |    |
| 4  | 8657-501-530-00 | WHEEL/GAUGE ASSY   | *  | 2          |  |  |  |  |  |     |       |      |    |
| 5  | 8654-501-283-00 | BUSH/22X25X25      | *  | 4          |  |  |  |  |  |     |       |      |    |
| 6  | 8663-501-001-10 | PIN/22X106         | *  | 2          |  |  |  |  |  |     |       |      |    |
| 7  | V411-260-022-00 | WASHER, PL/M22     | *  | 2          |  |  |  |  |  |     |       |      |    |
| 8  | V760-150-000-00 | NIPPLE, GREASE     | *  | 2          |  |  |  |  |  |     |       |      |    |
| 9  | V304-460-016-00 | NUT/M16            | *  | 2          |  |  |  |  |  |     |       |      |    |
| 10 | V401-160-016-00 | WASHER, SP/M16     | *  | 2          |  |  |  |  |  |     |       |      |    |
| 11 | 8663-501-510-00 | STAY/GAUGE/LH COMP | *  | 1          |  |  |  |  |  |     |       |      |    |
| 12 | 8663-501-520-00 | STAY/GAUGE/RH COMP | *  | 1          |  |  |  |  |  |     |       |      |    |
| 13 |                 | BLANK              |    |            |  |  |  |  |  |     | ----- |      |    |
| 13 | 8595-501-001-20 | WHEEL/GAUGE/FRONT  | *  | 1          |  |  |  |  |  |     |       |      |    |
| 14 | V211-260-802-00 | BOLT/S             | *  | 4          |  |  |  |  |  |     |       |      |    |
| 15 |                 | BLANK              |    |            |  |  |  |  |  |     | ----- |      |    |
| 15 | 8595-501-001-20 | WHEEL/GAUGE/FRONT  | *  | 2          |  |  |  |  |  |     |       |      |    |
| 16 |                 | BLANK              |    |            |  |  |  |  |  |     | ----- |      |    |
| 16 | 8663-501-051-00 | PIN/12X117         | *  | 2          |  |  |  |  |  |     |       |      |    |
| 17 | V360-260-012-00 | NUT/WASHER         | *  | 2          |  |  |  |  |  |     |       |      |    |
|    |                 |                    |    |            |  |  |  |  |  |     |       |      |    |
|    |                 |                    |    |            |  |  |  |  |  |     |       |      |    |
|    |                 |                    |    |            |  |  |  |  |  |     |       |      |    |
|    |                 |                    |    |            |  |  |  |  |  |     |       |      |    |
|    |                 |                    |    |            |  |  |  |  |  |     |       |      |    |
|    |                 |                    |    |            |  |  |  |  |  |     |       |      |    |
|    |                 |                    |    |            |  |  |  |  |  |     |       |      |    |
|    |                 |                    |    |            |  |  |  |  |  |     |       |      |    |
|    |                 |                    |    |            |  |  |  |  |  |     |       |      |    |
|    |                 |                    |    |            |  |  |  |  |  |     |       |      |    |

FIG.601 LINK SYSTEM



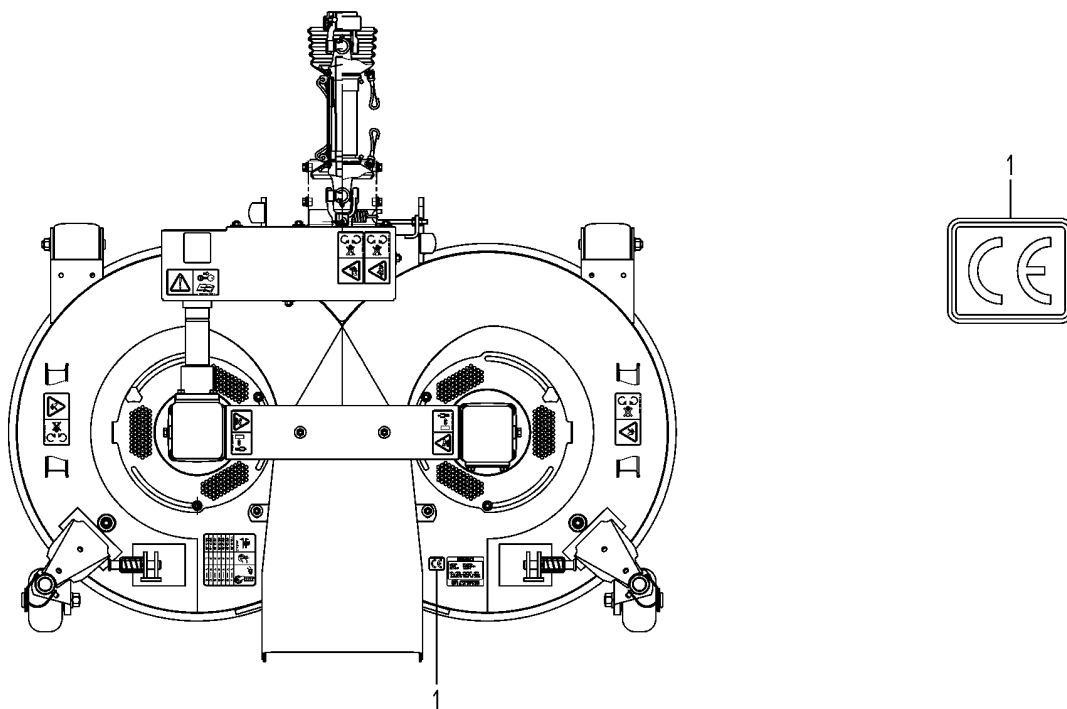
| 図番 | 部品コード           | 品名                  | 仕様 | 型式         |  |  |  | 代替性 | 色番号 | グループ | 備考 |
|----|-----------------|---------------------|----|------------|--|--|--|-----|-----|------|----|
|    |                 |                     |    | SCM<br>B48 |  |  |  |     |     |      |    |
| 1  |                 | BLANK               |    |            |  |  |  | 7F  |     |      |    |
| 1A |                 | BLANK               |    |            |  |  |  | 7F  |     |      |    |
| 1B | 8663-608-210-20 | ARM/FRONT COMP      | *  | 1          |  |  |  | 7F  |     |      |    |
| 1C |                 | BLANK               |    |            |  |  |  | 7F  |     |      |    |
| 2  |                 | BLANK               |    |            |  |  |  |     |     |      |    |
| 2  | 8595-608-082-10 | PIN/16X96           | *  | 1          |  |  |  |     |     |      |    |
| 3  | 1560-601-028-00 | SPRING/HCO42        | *  | 1          |  |  |  |     |     |      |    |
| 4  | V580-140-504-00 | PIN, SPRING/5 X40 W | *  | 1          |  |  |  |     |     |      |    |
| 5  | 8657-608-720-00 | FORK/M22 COMP       | *  | 2          |  |  |  |     |     |      |    |
| 6  |                 | BLANK               |    |            |  |  |  |     |     |      |    |
| 6  | 8595-608-082-10 | PIN/16X96           | *  | 2          |  |  |  |     |     |      |    |
| 7  | 1560-601-028-00 | SPRING/HCO42        | *  | 2          |  |  |  |     |     |      |    |
| 8  | V580-140-504-00 | PIN, SPRING/5 X40 W | *  | 2          |  |  |  |     |     |      |    |
| 9  |                 | BLANK               |    |            |  |  |  |     |     |      |    |
| 9  | V334-460-022-00 | NUT                 | *  | 2          |  |  |  |     |     |      |    |
|    |                 |                     |    |            |  |  |  |     |     |      |    |
|    |                 |                     |    |            |  |  |  |     |     |      |    |
|    |                 |                     |    |            |  |  |  |     |     |      |    |
|    |                 |                     |    |            |  |  |  |     |     |      |    |
|    |                 |                     |    |            |  |  |  |     |     |      |    |
|    |                 |                     |    |            |  |  |  |     |     |      |    |
|    |                 |                     |    |            |  |  |  |     |     |      |    |
|    |                 |                     |    |            |  |  |  |     |     |      |    |
|    |                 |                     |    |            |  |  |  |     |     |      |    |
|    |                 |                     |    |            |  |  |  |     |     |      |    |
|    |                 |                     |    |            |  |  |  |     |     |      |    |
|    |                 |                     |    |            |  |  |  |     |     |      |    |
|    |                 |                     |    |            |  |  |  |     |     |      |    |
|    |                 |                     |    |            |  |  |  |     |     |      |    |

FIG.901 LABEL



| 図番 | 部品コード           | 品名                 | 仕様 | 型式  |     |  |  |  |  | 代替性 | 色番号 | グループ | 備考 |
|----|-----------------|--------------------|----|-----|-----|--|--|--|--|-----|-----|------|----|
|    |                 |                    |    | SCM | B48 |  |  |  |  |     |     |      |    |
| 1  | 8595-901-006-00 | LABEL/WARNING/BELT | *  | 1   |     |  |  |  |  |     |     |      |    |
| 2  | 8595-901-007-00 | LABEL/WARNING/HOT  | *  | 2   |     |  |  |  |  |     |     |      |    |
| 3  | 2500-901-014-30 | LABEL/DANGER       | *  | 2   |     |  |  |  |  |     |     |      |    |
| 4  | 8654-901-002-00 | LABEL/PTO          | *  | 1   |     |  |  |  |  |     |     |      |    |
| 5  | 1593-901-015-00 | LABEL/MAINTENANCE  | *  | 1   |     |  |  |  |  |     |     |      |    |
| 6  | 8674-901-001-00 | LABEL/GAUGEWHEEL   | *  | 1   |     |  |  |  |  |     |     |      |    |
|    |                 |                    |    |     |     |  |  |  |  |     |     |      |    |
|    |                 |                    |    |     |     |  |  |  |  |     |     |      |    |
|    |                 |                    |    |     |     |  |  |  |  |     |     |      |    |
|    |                 |                    |    |     |     |  |  |  |  |     |     |      |    |
|    |                 |                    |    |     |     |  |  |  |  |     |     |      |    |
|    |                 |                    |    |     |     |  |  |  |  |     |     |      |    |
|    |                 |                    |    |     |     |  |  |  |  |     |     |      |    |
|    |                 |                    |    |     |     |  |  |  |  |     |     |      |    |
|    |                 |                    |    |     |     |  |  |  |  |     |     |      |    |
|    |                 |                    |    |     |     |  |  |  |  |     |     |      |    |
|    |                 |                    |    |     |     |  |  |  |  |     |     |      |    |
|    |                 |                    |    |     |     |  |  |  |  |     |     |      |    |
|    |                 |                    |    |     |     |  |  |  |  |     |     |      |    |
|    |                 |                    |    |     |     |  |  |  |  |     |     |      |    |
|    |                 |                    |    |     |     |  |  |  |  |     |     |      |    |
|    |                 |                    |    |     |     |  |  |  |  |     |     |      |    |
|    |                 |                    |    |     |     |  |  |  |  |     |     |      |    |
|    |                 |                    |    |     |     |  |  |  |  |     |     |      |    |
|    |                 |                    |    |     |     |  |  |  |  |     |     |      |    |
|    |                 |                    |    |     |     |  |  |  |  |     |     |      |    |
|    |                 |                    |    |     |     |  |  |  |  |     |     |      |    |
|    |                 |                    |    |     |     |  |  |  |  |     |     |      |    |
|    |                 |                    |    |     |     |  |  |  |  |     |     |      |    |
|    |                 |                    |    |     |     |  |  |  |  |     |     |      |    |
|    |                 |                    |    |     |     |  |  |  |  |     |     |      |    |
|    |                 |                    |    |     |     |  |  |  |  |     |     |      |    |
|    |                 |                    |    |     |     |  |  |  |  |     |     |      |    |

FIG.902 LABEL(CE)



| 図番 | 部品コード           | 品名       | 仕様 | 型式  |  |  |  |  | 代替性 | 色番号 | グループ | 備考 |
|----|-----------------|----------|----|-----|--|--|--|--|-----|-----|------|----|
|    |                 |          |    | SCM |  |  |  |  |     |     |      |    |
| 1  | 2500-901-027-00 | LABEL/CE | *  | 1   |  |  |  |  |     |     |      |    |
|    |                 |          |    |     |  |  |  |  |     |     |      |    |
|    |                 |          |    |     |  |  |  |  |     |     |      |    |
|    |                 |          |    |     |  |  |  |  |     |     |      |    |
|    |                 |          |    |     |  |  |  |  |     |     |      |    |
|    |                 |          |    |     |  |  |  |  |     |     |      |    |
|    |                 |          |    |     |  |  |  |  |     |     |      |    |
|    |                 |          |    |     |  |  |  |  |     |     |      |    |
|    |                 |          |    |     |  |  |  |  |     |     |      |    |
|    |                 |          |    |     |  |  |  |  |     |     |      |    |
|    |                 |          |    |     |  |  |  |  |     |     |      |    |
|    |                 |          |    |     |  |  |  |  |     |     |      |    |
|    |                 |          |    |     |  |  |  |  |     |     |      |    |
|    |                 |          |    |     |  |  |  |  |     |     |      |    |
|    |                 |          |    |     |  |  |  |  |     |     |      |    |
|    |                 |          |    |     |  |  |  |  |     |     |      |    |
|    |                 |          |    |     |  |  |  |  |     |     |      |    |
|    |                 |          |    |     |  |  |  |  |     |     |      |    |
|    |                 |          |    |     |  |  |  |  |     |     |      |    |
|    |                 |          |    |     |  |  |  |  |     |     |      |    |
|    |                 |          |    |     |  |  |  |  |     |     |      |    |
|    |                 |          |    |     |  |  |  |  |     |     |      |    |
|    |                 |          |    |     |  |  |  |  |     |     |      |    |
|    |                 |          |    |     |  |  |  |  |     |     |      |    |
|    |                 |          |    |     |  |  |  |  |     |     |      |    |
|    |                 |          |    |     |  |  |  |  |     |     |      |    |

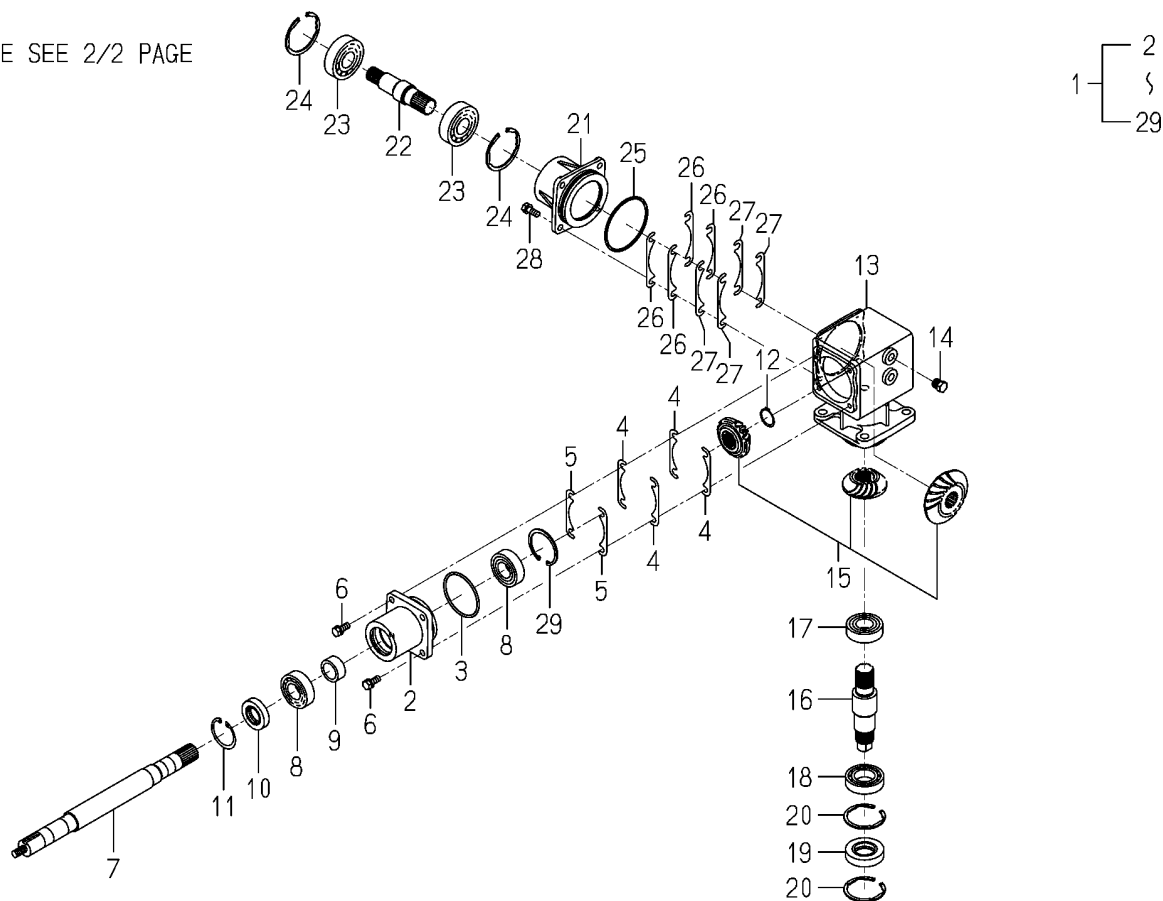
FIG.903 PIN(SAFETY)



| 図番 | 部品コード                  | 品名        | 仕様 | 型式         |  |  |  |  |  | 代替性 | 色番号 | グループ | 備考    |
|----|------------------------|-----------|----|------------|--|--|--|--|--|-----|-----|------|-------|
|    |                        |           |    | SCM<br>B48 |  |  |  |  |  |     |     |      |       |
| 1  |                        | BLANK     |    |            |  |  |  |  |  |     |     |      | ----- |
| 1  | <b>8670-301-002-10</b> | PIN/08X16 | *  | 4          |  |  |  |  |  |     |     |      |       |
|    |                        |           |    |            |  |  |  |  |  |     |     |      |       |
|    |                        |           |    |            |  |  |  |  |  |     |     |      |       |
|    |                        |           |    |            |  |  |  |  |  |     |     |      |       |
|    |                        |           |    |            |  |  |  |  |  |     |     |      |       |
|    |                        |           |    |            |  |  |  |  |  |     |     |      |       |
|    |                        |           |    |            |  |  |  |  |  |     |     |      |       |
|    |                        |           |    |            |  |  |  |  |  |     |     |      |       |
|    |                        |           |    |            |  |  |  |  |  |     |     |      |       |
|    |                        |           |    |            |  |  |  |  |  |     |     |      |       |
|    |                        |           |    |            |  |  |  |  |  |     |     |      |       |
|    |                        |           |    |            |  |  |  |  |  |     |     |      |       |
|    |                        |           |    |            |  |  |  |  |  |     |     |      |       |
|    |                        |           |    |            |  |  |  |  |  |     |     |      |       |
|    |                        |           |    |            |  |  |  |  |  |     |     |      |       |
|    |                        |           |    |            |  |  |  |  |  |     |     |      |       |
|    |                        |           |    |            |  |  |  |  |  |     |     |      |       |
|    |                        |           |    |            |  |  |  |  |  |     |     |      |       |
|    |                        |           |    |            |  |  |  |  |  |     |     |      |       |
|    |                        |           |    |            |  |  |  |  |  |     |     |      |       |
|    |                        |           |    |            |  |  |  |  |  |     |     |      |       |
|    |                        |           |    |            |  |  |  |  |  |     |     |      |       |
|    |                        |           |    |            |  |  |  |  |  |     |     |      |       |
|    |                        |           |    |            |  |  |  |  |  |     |     |      |       |
|    |                        |           |    |            |  |  |  |  |  |     |     |      |       |
|    |                        |           |    |            |  |  |  |  |  |     |     |      |       |
|    |                        |           |    |            |  |  |  |  |  |     |     |      |       |
|    |                        |           |    |            |  |  |  |  |  |     |     |      |       |
|    |                        |           |    |            |  |  |  |  |  |     |     |      |       |
|    |                        |           |    |            |  |  |  |  |  |     |     |      |       |
|    |                        |           |    |            |  |  |  |  |  |     |     |      |       |
|    |                        |           |    |            |  |  |  |  |  |     |     |      |       |
|    |                        |           |    |            |  |  |  |  |  |     |     |      |       |

FIG.P01 CASE(BEVEL)ASSY(REPAIR) (1/2)

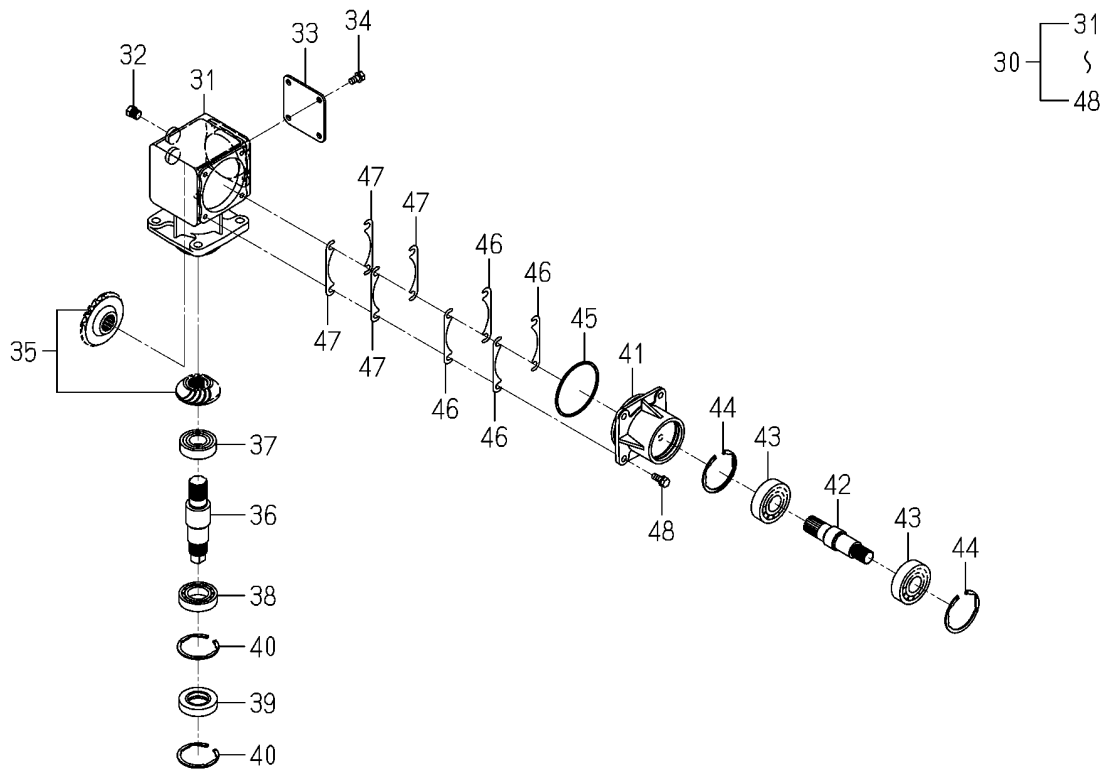
30-PLEASE SEE 2/2 PAGE



| 図番 | 部品コード           | 品名                   | 仕様 | 型式      |  |  |  |  |  | 代替性 | 色番号 | グループ | 備考 |
|----|-----------------|----------------------|----|---------|--|--|--|--|--|-----|-----|------|----|
|    |                 |                      |    | SCM B48 |  |  |  |  |  |     |     |      |    |
| 1  | 8674-202-310-20 | CASE/BEVEL/LH ASSY   | R  | 1       |  |  |  |  |  |     |     |      |    |
| 2  | 8674-202-001-20 | METAL/CASE           | R  | 1       |  |  |  |  |  |     |     |      |    |
| 3  | V721-103-106-50 | O-RING/G65           | R  | 1       |  |  |  |  |  |     |     |      |    |
| 4  | 8663-202-055-00 | SHIM/0.1             | R  | 4       |  |  |  |  |  |     |     |      |    |
| 5  | 8663-202-056-00 | SHIM/0.2             | R  | 2       |  |  |  |  |  |     |     |      |    |
| 6  | V211-560-802-00 | BOLT/M8X20           | R  | 4       |  |  |  |  |  |     |     |      |    |
| 7  | 8674-202-002-00 | SHAFT/LH             | R  | 1       |  |  |  |  |  |     |     |      |    |
| 8  | 1594-221-001-00 | BEARING/BALL 6205SH2 | R  | 2       |  |  |  |  |  |     |     |      |    |
| 9  | 8674-202-003-00 | COLLAR/25X34X15      | R  | 1       |  |  |  |  |  |     |     |      |    |
| 10 | V744-128-451-10 | SEAL, OIL/TC284511   | R  | 1       |  |  |  |  |  |     |     |      |    |
| 11 | V705-140-045-00 | RING, SNAP/45 C      | R  | 1       |  |  |  |  |  |     |     |      |    |
| 12 | V704-140-025-00 | RING, SNAP/25 C      | R  | 1       |  |  |  |  |  |     |     |      |    |
| 13 | 8674-202-004-00 | CASE/BEVEL           | R  | 1       |  |  |  |  |  |     |     |      |    |
| 14 | 7955-201-026-00 | PLUG, DRAIN (1/4)    | R  | 2       |  |  |  |  |  |     |     |      |    |
| 15 | 8674-202-210-00 | GEAR/B/21-25-21 SET  | R  | 1       |  |  |  |  |  |     |     |      |    |
| 16 | 8674-202-007-00 | SHAFT/BLADE          | R  | 1       |  |  |  |  |  |     |     |      |    |
| 17 | 1594-221-001-00 | BEARING/BALL 6205SH2 | R  | 1       |  |  |  |  |  |     |     |      |    |
| 18 | V600-110-600-60 | BEARING, RB 6006     | R  | 1       |  |  |  |  |  |     |     |      |    |
| 19 | V744-130-551-20 | SEAL, OIL/TC305512   | R  | 1       |  |  |  |  |  |     |     |      |    |
| 20 | V707-140-055-00 | RING/SNAP            | R  | 2       |  |  |  |  |  |     |     |      |    |
| 21 | 8667-201-002-00 | METAL/INPUT          | R  | 1       |  |  |  |  |  |     |     |      |    |
| 22 | 8674-202-009-00 | SHAFT/CASE           | R  | 1       |  |  |  |  |  |     |     |      |    |
| 23 | 1594-218-001-00 | BEARING/BALL 6305SH2 | R  | 2       |  |  |  |  |  |     |     |      |    |
| 24 | V707-140-062-00 | RING/SNAP            | R  | 2       |  |  |  |  |  |     |     |      |    |
| 25 | V721-103-108-00 | O-RING/G80           | R  | 1       |  |  |  |  |  |     |     |      |    |
| 26 | 8595-201-021-00 | SHIM/0.1             | R  | 4       |  |  |  |  |  |     |     |      |    |
| 27 | 8595-201-022-00 | SHIM/0.2             | R  | 4       |  |  |  |  |  |     |     |      |    |
| 28 | V211-560-802-00 | BOLT/M8X20           | R  | 4       |  |  |  |  |  |     |     |      |    |
| 29 | V705-140-052-00 | RING, SNAP/52 C      | R  | 1       |  |  |  |  |  |     |     |      |    |
| 30 | 8674-202-320-00 | CASE/BEVEL/RH ASSY   | R  | 1       |  |  |  |  |  |     |     |      |    |

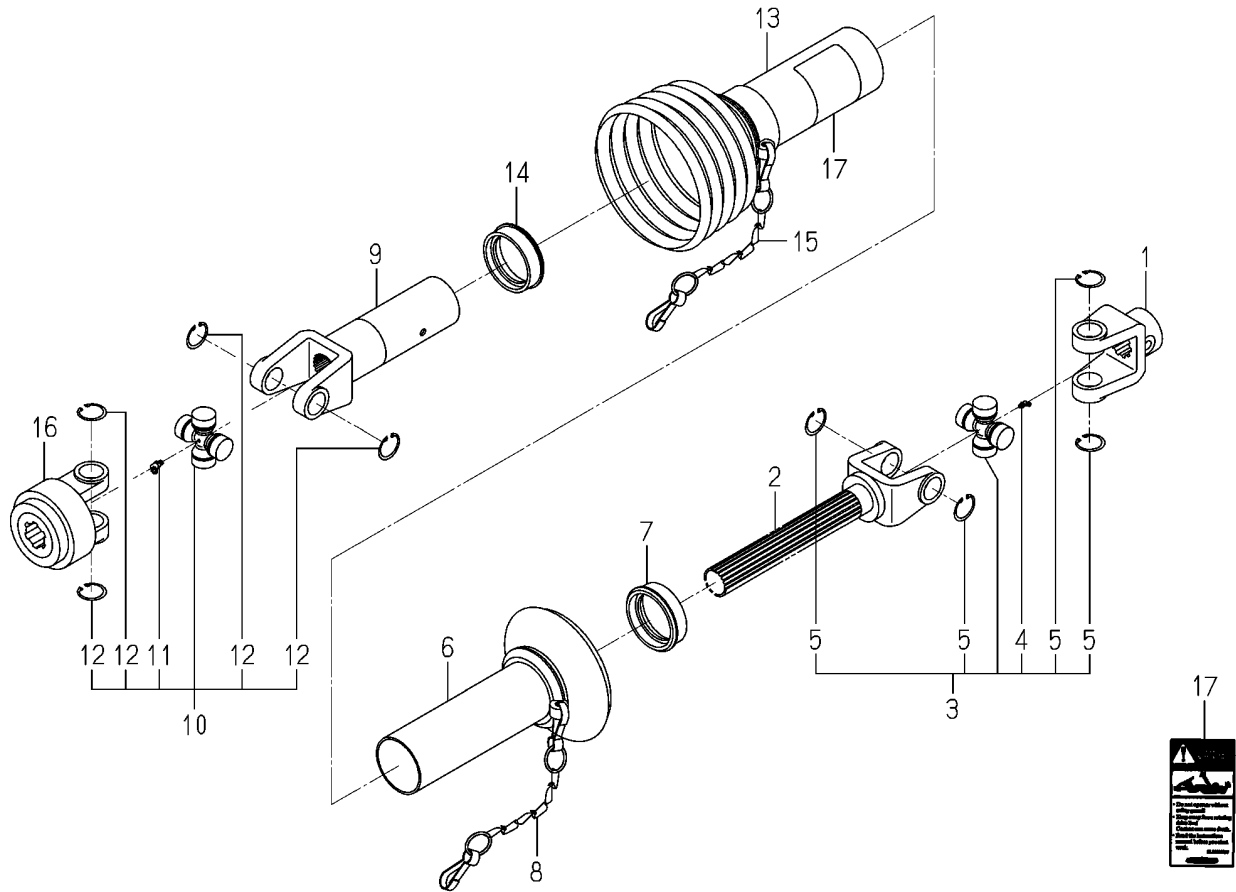


FIG.P01A CASE(BEVEL)ASSY(REPAIR) (2/2)



| 図番 | 部品コード           | 品名                   | 仕様 | 型式         |  |  |  |  | 代替性 | 色番号 | グループ | 備考 |
|----|-----------------|----------------------|----|------------|--|--|--|--|-----|-----|------|----|
|    |                 |                      |    | SCM<br>B48 |  |  |  |  |     |     |      |    |
| 31 | 8674-202-004-00 | CASE/BEVEL           | R  | 1          |  |  |  |  |     |     |      |    |
| 32 | 7955-201-026-00 | PLUG, DRAIN (1/4)    | R  | 2          |  |  |  |  |     |     |      |    |
| 33 | 8674-202-006-00 | COVER/CASE           | R  | 4          |  |  |  |  |     |     |      |    |
| 34 | V211-260-801-60 | BOLT, SEMS (S) M8X16 | R  | 4          |  |  |  |  |     |     |      |    |
| 35 | 8674-202-220-00 | GEAR/BEVEL/25-2 SET  | R  | 1          |  |  |  |  |     |     |      |    |
| 36 | 8674-202-007-00 | SHAFT/BLADE          | R  | 1          |  |  |  |  |     |     |      |    |
| 37 | 1594-221-001-00 | BEARING/BALL 6205SH2 | R  | 1          |  |  |  |  |     |     |      |    |
| 38 | V600-110-600-60 | BEARING, RB 6006     | R  | 1          |  |  |  |  |     |     |      |    |
| 39 | V744-130-551-20 | SEAL, OIL/TC305512   | R  | 1          |  |  |  |  |     |     |      |    |
| 40 | V707-140-055-00 | RING/SNAP            | R  | 2          |  |  |  |  |     |     |      |    |
| 41 | 8667-201-002-00 | METAL/INPUT          | R  | 1          |  |  |  |  |     |     |      |    |
| 42 | 8674-202-009-00 | SHAFT/CASE           | R  | 1          |  |  |  |  |     |     |      |    |
| 43 | 1594-218-001-00 | BEARING/BALL 6305SH2 | R  | 2          |  |  |  |  |     |     |      |    |
| 44 | V707-140-062-00 | RING/SNAP            | R  | 2          |  |  |  |  |     |     |      |    |
| 45 | V721-103-108-00 | O-RING/G80           | R  | 1          |  |  |  |  |     |     |      |    |
| 46 | 8595-201-021-00 | SHIM/0.1             | R  | 4          |  |  |  |  |     |     |      |    |
| 47 | 8595-201-022-00 | SHIM/0.2             | R  | 4          |  |  |  |  |     |     |      |    |
| 48 | V211-560-802-00 | BOLT/M8X20           | R  | 4          |  |  |  |  |     |     |      |    |
|    |                 |                      |    |            |  |  |  |  |     |     |      |    |
|    |                 |                      |    |            |  |  |  |  |     |     |      |    |
|    |                 |                      |    |            |  |  |  |  |     |     |      |    |
|    |                 |                      |    |            |  |  |  |  |     |     |      |    |
|    |                 |                      |    |            |  |  |  |  |     |     |      |    |
|    |                 |                      |    |            |  |  |  |  |     |     |      |    |
|    |                 |                      |    |            |  |  |  |  |     |     |      |    |
|    |                 |                      |    |            |  |  |  |  |     |     |      |    |
|    |                 |                      |    |            |  |  |  |  |     |     |      |    |
|    |                 |                      |    |            |  |  |  |  |     |     |      |    |
|    |                 |                      |    |            |  |  |  |  |     |     |      |    |
|    |                 |                      |    |            |  |  |  |  |     |     |      |    |

FIG.S01 COMPONENT PARTS FOR 8663-101-510-00 ON Fig.101



| 図番 | 部品コード           | 品名                   | 仕様 | 型式      |  |  |  |  |  | 代替性 | 色番号 | グループ | 備考 |
|----|-----------------|----------------------|----|---------|--|--|--|--|--|-----|-----|------|----|
|    |                 |                      |    | SCM B48 |  |  |  |  |  |     |     |      |    |
| 1  | 8654-101-221-00 | FITTINGYOKE          | *  | 1       |  |  |  |  |  |     |     |      |    |
| 2  | 8663-101-211-00 | SHAFTYOKE            | *  | 1       |  |  |  |  |  |     |     |      |    |
| 3  | 8654-101-230-00 | JOURNALSASSE         | *  | 1       |  |  |  |  |  |     |     |      |    |
| 4  | 8654-101-232-00 | GREASENIPPLE         | *  | 1       |  |  |  |  |  |     |     |      |    |
| 5  | 8654-101-233-00 | SURCLIP/HOLE         | *  | 4       |  |  |  |  |  |     |     |      |    |
| 6  | 8663-101-521-00 | SAFETYGUARD/IN       | *  | 1       |  |  |  |  |  |     |     |      |    |
| 7  | 7821-102-008-00 | RING/SLIDE           | *  | 1       |  |  |  |  |  |     |     |      |    |
| 8  | 7821-102-220-00 | CHAIN ASSY           | *  | 1       |  |  |  |  |  |     |     |      |    |
| 9  | 8595-101-731-00 | SLEEVEYOKE           | *  | 1       |  |  |  |  |  |     |     |      |    |
| 10 | 8654-101-230-00 | JOURNALSASSE         | *  | 1       |  |  |  |  |  |     |     |      |    |
| 11 | 8654-101-232-00 | GREASENIPPLE         | *  | 1       |  |  |  |  |  |     |     |      |    |
| 12 | 8654-101-233-00 | SURCLIP/HOLE         | *  | 4       |  |  |  |  |  |     |     |      |    |
| 13 | 8663-101-531-00 | SAFETYGUARD/OUT      | *  | 1       |  |  |  |  |  |     |     |      |    |
| 14 | 7821-102-008-00 | RING/SLIDE           | *  | 1       |  |  |  |  |  |     |     |      |    |
| 15 | 7821-102-220-00 | CHAIN ASSY           | *  | 1       |  |  |  |  |  |     |     |      |    |
| 16 | 8657-101-501-00 | AS YOKE ASSY         | *  | 1       |  |  |  |  |  |     |     |      |    |
| 17 | 8658-101-674-00 | LABEL/DANGER/JOINT/G | *  | 1       |  |  |  |  |  |     |     |      |    |
|    |                 |                      |    |         |  |  |  |  |  |     |     |      |    |
|    |                 |                      |    |         |  |  |  |  |  |     |     |      |    |
|    |                 |                      |    |         |  |  |  |  |  |     |     |      |    |
|    |                 |                      |    |         |  |  |  |  |  |     |     |      |    |
|    |                 |                      |    |         |  |  |  |  |  |     |     |      |    |
|    |                 |                      |    |         |  |  |  |  |  |     |     |      |    |
|    |                 |                      |    |         |  |  |  |  |  |     |     |      |    |
|    |                 |                      |    |         |  |  |  |  |  |     |     |      |    |
|    |                 |                      |    |         |  |  |  |  |  |     |     |      |    |
|    |                 |                      |    |         |  |  |  |  |  |     |     |      |    |