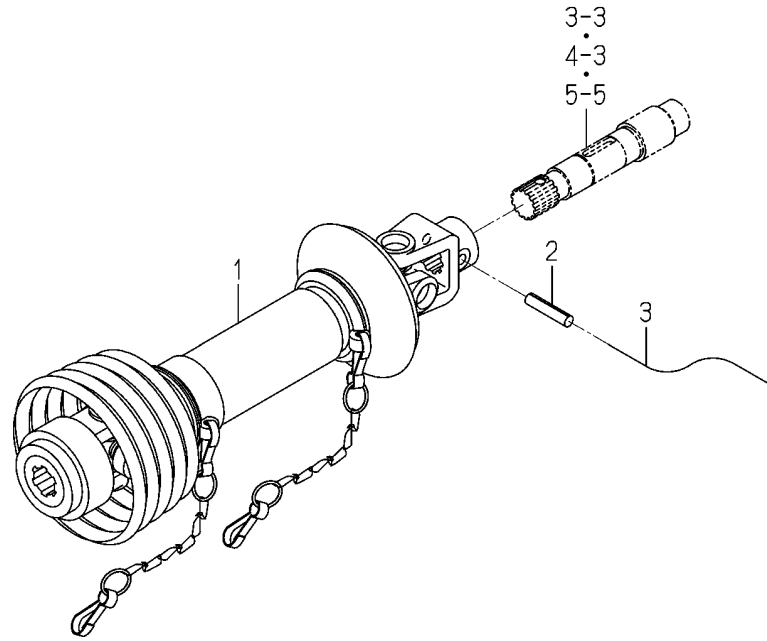
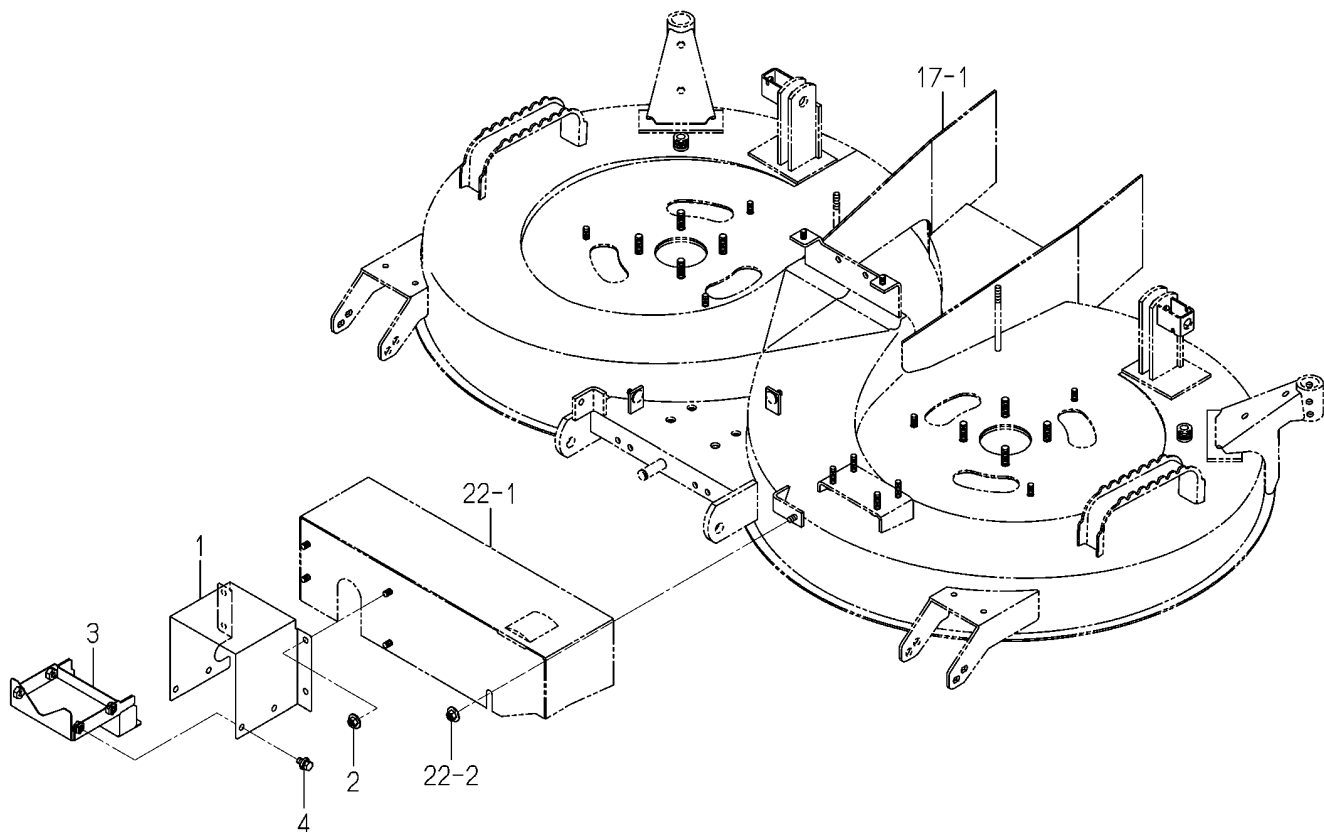

FIG.001 JOINT(UNIVERSAL)SYSTEM



図番	部品コード	品名	仕様	型式				代替性	色番号	グループ	備考
				SCMA48 SXG22F	SCMA54 SXG22F						
1	8663-101-510-00	JOINT/UNIVERSAL SET	*	1	1						030
2	V580-140-804-00	PIN, SPRING/8X40 W	*	1	1						
3	8674-101-001-00	WIRE/1. 6X150	*	1	1						

FIG.002 COVER(JOINT)SYSTEM(SCMA54)(NO.500001-)



図番	部品コード	品名	仕様	型式				代替性	色番号	グループ	備考
				SCMA48 SXG22F	SCMA54 SXG22F						
1	8663-407-052-00	COVER/JOINT			1 500001-				7F		
2	V363-260-008-00	NUT/WASHER/M8			4 500001-						
3	8663-407-540-10	COVER/YOKE COMP			1 500001-			7F			
4	V211-360-801-60	BOLT, SP/M8X16			4 500001-						

FIG.003 PULLEY SYSTEM(SCMA48)

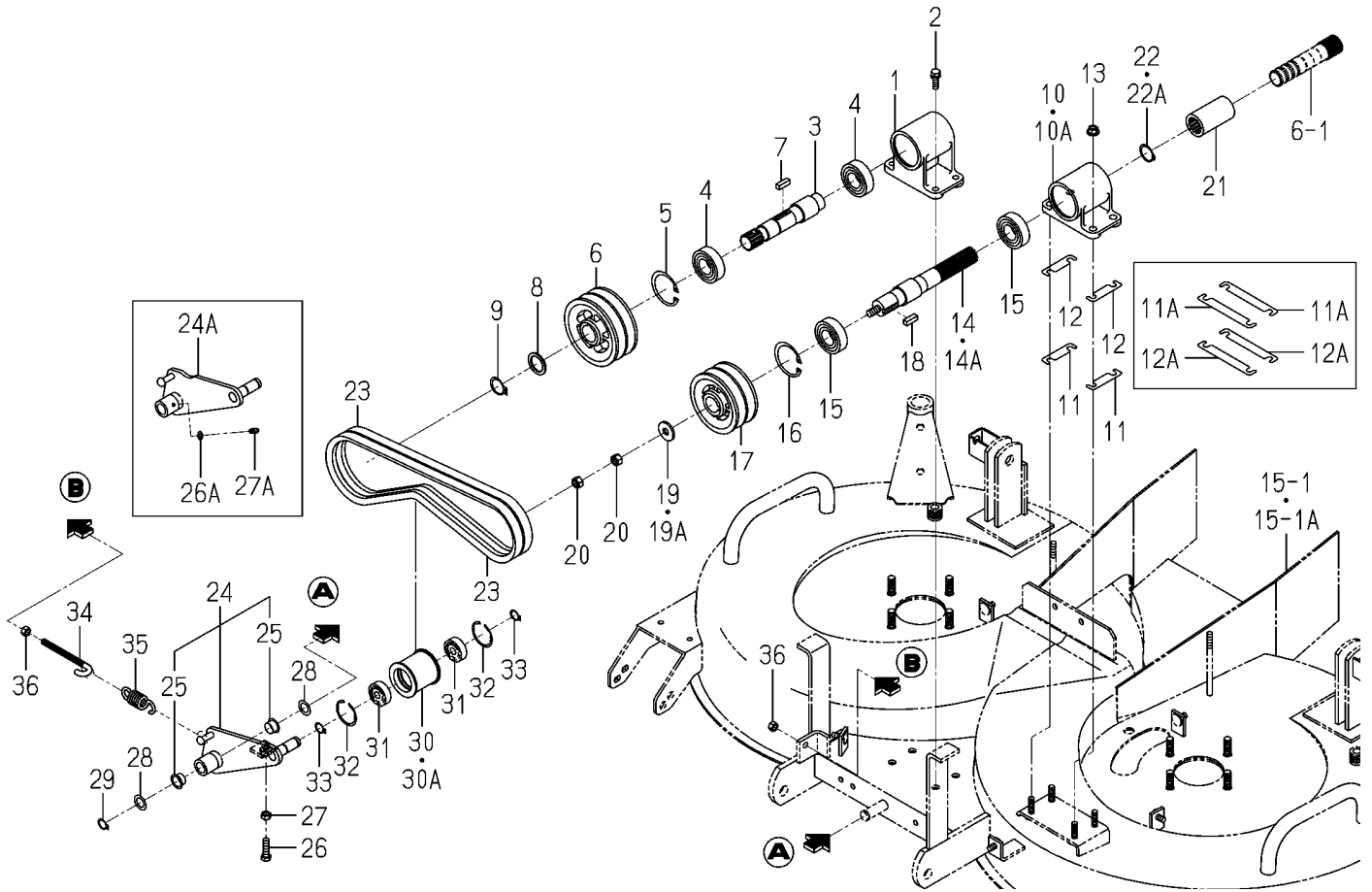

図番	部品コード	品名	仕様	型式				代替性	色番号	グループ	備考
				SCMA48 SXG22F	SCMA54 SXG22F						
1	8663-201-051-00	METAL/INPUT	*	1							
2	V211-260-802-50	BOLT, S/M8X25	*	4							
3	8663-201-052-00	SHAFT/INPUT	*	1							
4	V600-150-620-50	BEARING, RB/6205SS	*	2							
5	V705-140-052-00	RING, SNAP/52 C	*	1							
6	8663-201-053-00	PULLEY/V2B102	*	1							
7	8663-201-054-00	KEY/07X07X22	*	1							
8	1415-216-602-00	WASHER/26X35X2	*	1							
9	V704-140-025-00	RING, SNAP/25 C	*	1							
10	8663-201-055-00	METAL/OUTPUT	*	1 -400174							
10A	8663-201-055-10	METAL/OUTPUT	*	1 400175-							
11	8663-201-059-00	SHIM/1.0	*	2 -401161							
11A	8663-201-066-00	SHIM/0.5	*	2 401162-							
12	8663-201-061-00	SHIM/0.5	*	2 -401161							
12A	8663-201-068-00	SHIM/1.0	*	2 401162-							
13	V363-260-008-00	NUT/WASHER/M8	*	4							
14	8663-201-056-00	SHAFT/48/LH/Front	*	1 -401340							
14A	8663-201-056-10	SHAFT/48/LH/Front	*	1 401341-							
15	V600-150-620-50	BEARING, RB/6205SS	*	2							
16	V705-140-052-00	RING, SNAP/52 C	*	1							
17	8663-201-057-10	PULLEY/V2B90	*	1							
18	8663-201-054-00	KEY/07X07X22	*	1							
19	3659-170-003-00	WASHER/11X30X3	*	1 -300993							
19A	8663-201-063-00	WASHER/11X30X03	*	1 300994-							
20	V304-260-010-00	NUT/M10	*	2							
21	1560-220-004-10	COUFRING/21X36X65	*	1							
22	V704-140-025-00	RING, SNAP/25 C	*	1 -401340							
22A	1725-218-006-00	RING/SNAP/CS25	*	1 401341-							
23	8663-201-058-10	BELT/VB036	*	2							
24	8663-201-510-30	ARM/TENSION ASSY	*	1 -401281							

FIG.003 PULLEY SYSTEM(SCMA48)

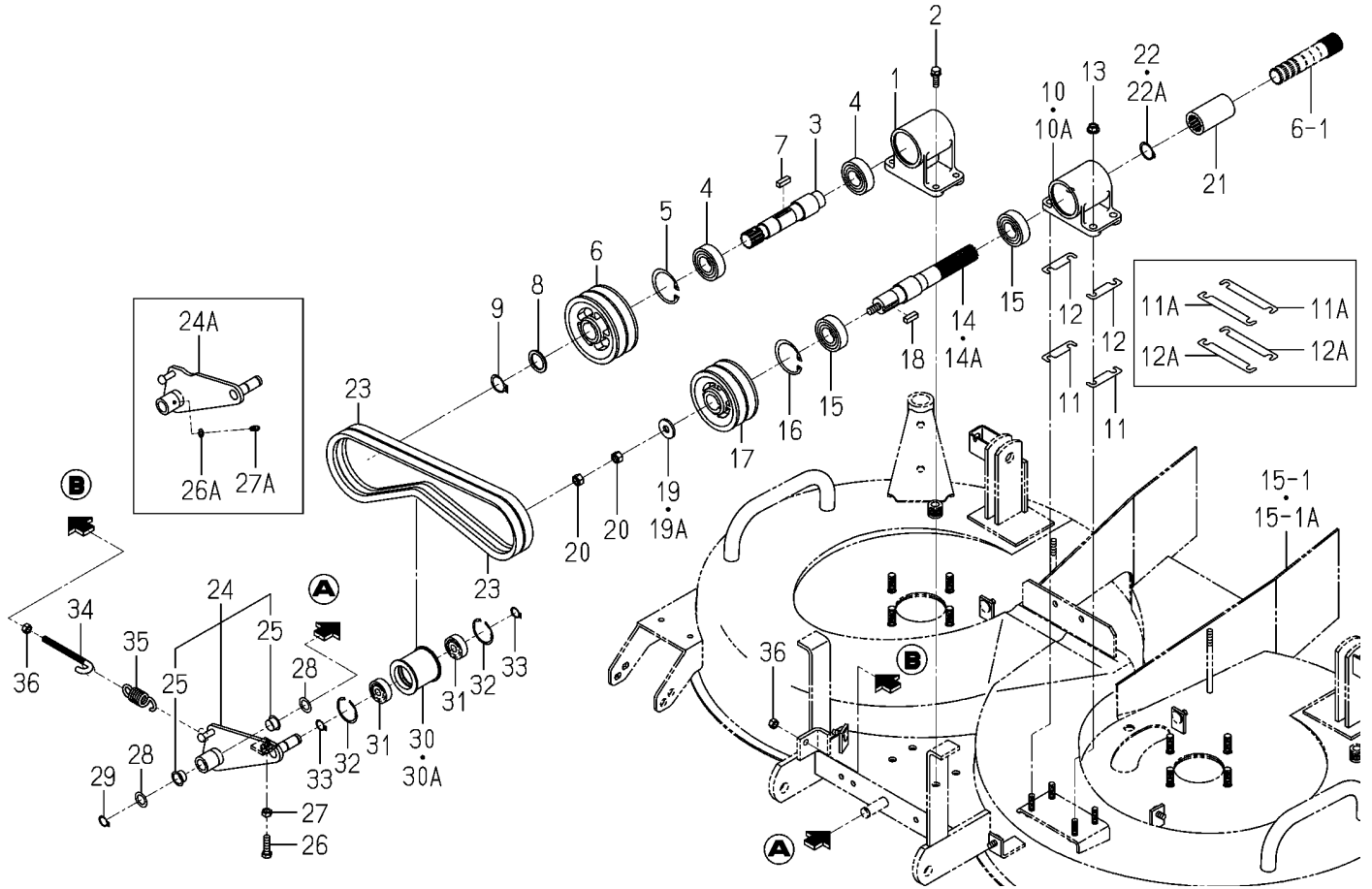

図番	部品コード	品名	仕様	型式				代替性	色番号	グループ	備考
				SCMA48 SXG22F	SCMA54 SXG22F						
24A	8663-201-510-50	ARM/TENSION ASSY	*	1 401282-							
25	2502-407-001-10	BUSH/15X17X11	*	2							
26	V201-260-803-00	BOLT/M8X30	*	1 -401274							
26A	V401-160-006-00	WASHER, SP/M6	*	1 401282-							
27	V304-260-008-00	NUT/M8	*	1 -401274							
27A	V760-150-000-00	NIPPLE, GREASE	*	1 401282-							
28	3517-205-007-00	WASHER	*	2							
29	V704-140-015-00	RING, SNAP/15 C	*	1							
30	8663-201-062-00	PULLY/TENSION/50X46	*	1 -300246							
30A	8663-201-062-10	PULLY/FT050X046	*	1 300247-							
31	V600-350-620-20	BEARING, RB/6202SS	*	2							
32	V705-140-035-00	RING, SNAP/35 C	*	2							
33	V704-140-015-00	RING, SNAP/15 C	*	2							
34	3737-341-007-00	ROD, CHAIN TENSION	*	1							
35	1337-401-006-00	SPRING	*	1							
36	V304-260-008-00	NUT/M8	*	2							

FIG.004 PULLEY SYSTEM(SCMA54)(NO.1-400725)

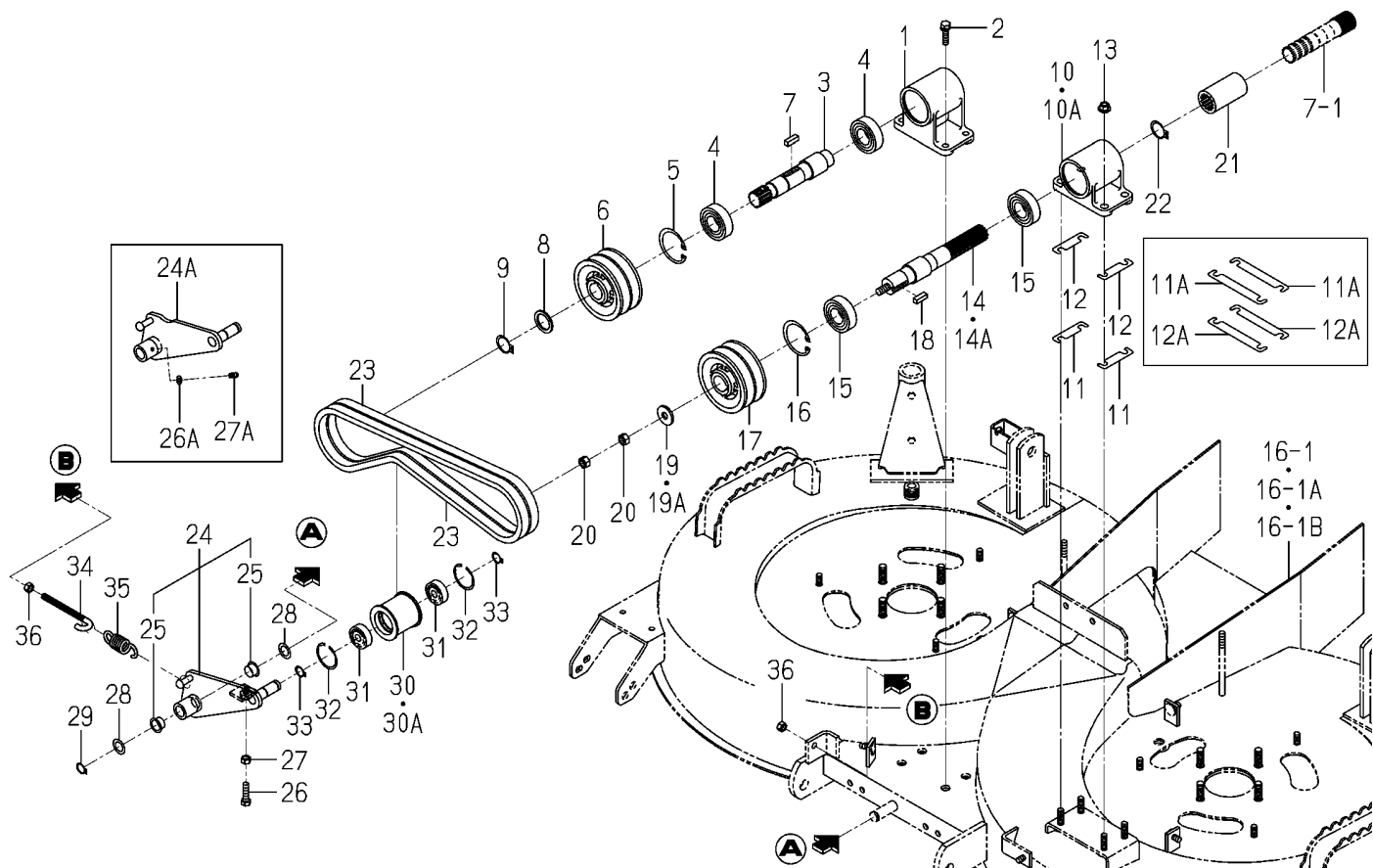

図番	部品コード	品名	仕様	型式				代替性	色番号	グループ	備考
				SCMA48 SXG22F	SCMA54 SXG22F						
1	8663-201-051-00	METAL/INPUT			1						
2	V211-260-802-50	BOLT, S/M8X25			-400725						
3	8663-201-052-00	SHAFT/INPUT			4						
4	V600-150-620-50	BEARING, RB/6205SS			-400725						
5	V705-140-052-00	RING, SNAP/52 C			1						
6	8665-201-051-00	PULLEY/V2B93			-400725						
7	8663-201-054-00	KEY/07X07X22			1						
8	1415-216-602-00	WASHER/26X35X2			-400725						
9	V704-140-025-00	RING, SNAP/25 C			1						
10	8663-201-055-00	METAL/OUTPUT			-400325						
10A	8663-201-055-10	METAL/OUTPUT			1						
11	8663-201-059-00	SHIM/1.0			-400725						
11A	8663-201-066-00	SHIM/0.5			2						
12	8663-201-061-00	SHIM/0.5			-400325						
12A	8663-201-068-00	SHIM/1.0			2						
13	V363-260-008-00	NUT/WASHER/M8			-400725						
14	8663-201-056-00	SHAFT/48/LH/Front			4						
14A	8663-201-056-10	SHAFT/48/LH/Front			-400725						
15	V600-150-620-50	BEARING, RB/6205SS			1						
16	V705-140-052-00	RING, SNAP/52 C			-400725						
17	8663-201-057-10	PULLEY/V2B90			1						
18	8663-201-054-00	KEY/07X07X22			-400725						
19	3659-170-003-00	WASHER/11X30X3			1						
19A	8663-201-063-00	WASHER/11X30X03			-300287						
20	V304-260-010-00	NUT/M10			1						
21	1560-220-004-10	COUPLING/21X36X65			-400725						
22	V704-140-025-00	RING, SNAP/25 C			1						
23	8665-201-052-10	BELT/VB038			-400725						
24	8663-201-510-30	ARM/TENSION ASSY			1						
24A	8663-201-510-50	ARM/TENSION ASSY			-400364						

FIG.004 PULLEY SYSTEM(SCMA54)(NO.1-400725)

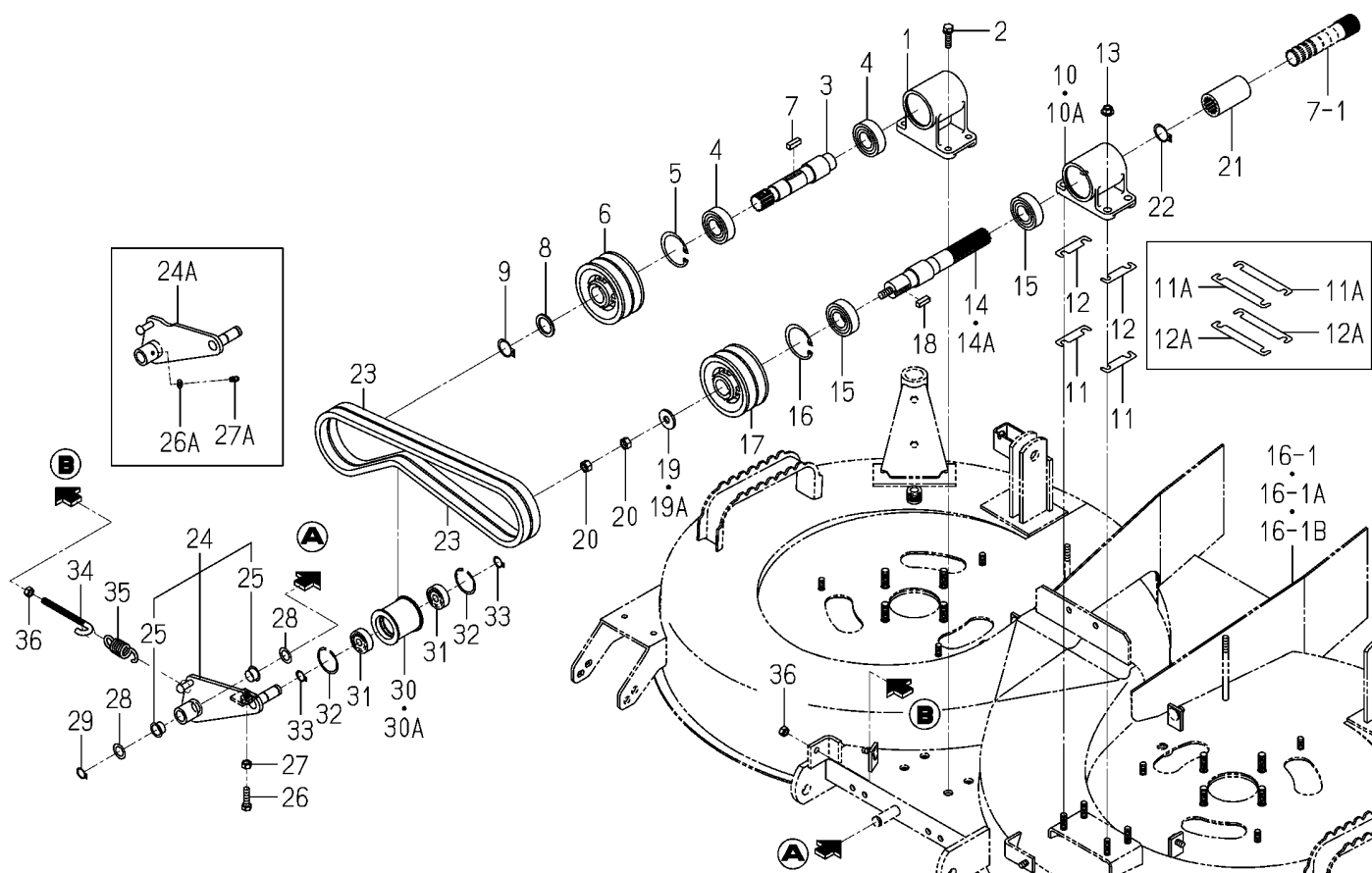

図番	部品コード	品名	仕様	型式				代替性	色番号	グループ	備考
				SCMA48 SXG22F	SCMA54 SXG22F						
25	2502-407-001-10	BUSH/15X17X11			2 -400725						
26	V201-260-803-00	BOLT/M8X30			1 -400343						
26A	V401-160-006-00	WASHER, SP/M6			1 -400725						
27	V304-260-008-00	NUT/M8			1 -400343						
27A	V760-150-000-00	NIPPLE, GREASE			1 -400725						
28	3517-205-007-00	WASHER			2 -400725						
29	V704-140-015-00	RING, SNAP/15 C			1 -400725						
30	8663-201-062-00	PULLY/TENSION/50X46			1 -300130						
30A	8663-201-062-10	PULLY/FT050X046			1 -400725						
31	V600-350-620-20	BEARING, RB/6202SS			2 -400725						
32	V705-140-035-00	RING, SNAP/35 C			2 -400725						
33	V704-140-015-00	RING, SNAP/15 C			2 -400725						
34	3737-341-007-00	ROD, CHAIN TENSION			1 -400725						
35	1337-401-006-00	SPRING			1 -400725						
36	V304-260-008-00	NUT/M8			2 -400725						

FIG.005 PULLEY SYSTEM(SCMA54)(NO.500001-)

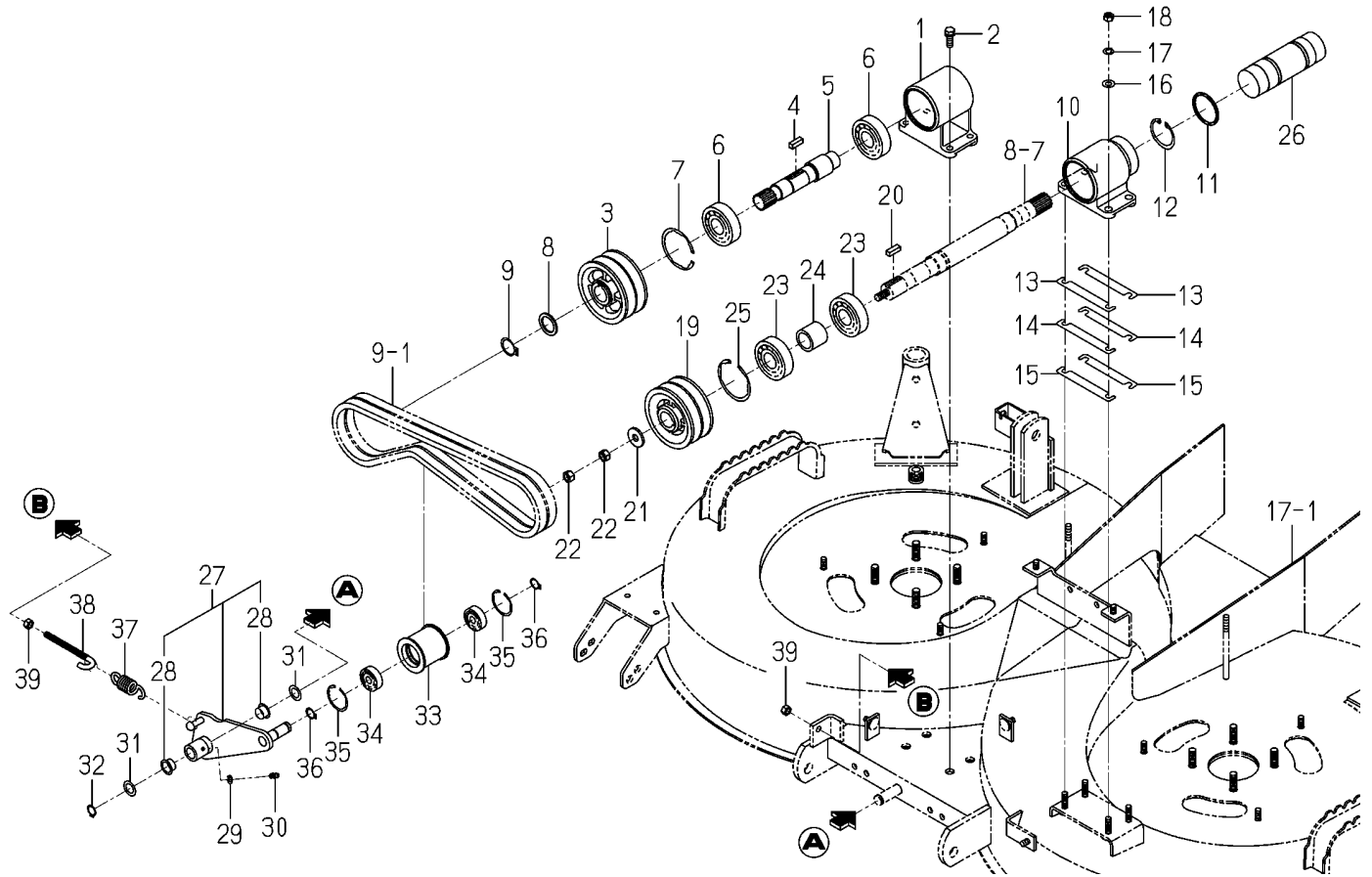

図番	部品コード	品名	仕様	型式					代替性	色番号	グループ	備考
				SCMA48 SXG22F	SCMA54 SXG22F							
1	8674-201-001-00	METAL/INPUT			1 500001-							
2	V211-560-802-50	BOLT, S/M8X25/7T			4 500001-							
3	8665-201-051-00	PULLEY/V2B93			1 500001-							
4	8663-201-054-00	KEY/07X07X22			1 500001-							
5	8674-201-002-00	SHAFT/INPUT			1 500001-							
6	V600-150-630-50	BEARING, RB/6305SS			2 500001-							
7	V707-140-062-00	RING, SNAP/R62			1 500001-							
8	1415-216-602-00	WASHER/26X35X2			1 500001-							
9	V704-140-025-00	RING, SNAP/25 C			1 500001-							
10	8674-201-003-10	METAL/PULLEY			1 500001-							
11	V720-103-504-40	O-RING/1A, P44			1 500001-							
12	V705-140-045-00	RING, SNAP/45 C			1 500001-							
13	8674-201-007-00	SHIM/0.2			2 500001-							
14	8663-201-066-00	SHIM/0.5			2 500001-							
15	8663-201-068-00	SHIM/1.0			2 500001-							
16	V411-260-008-00	WASHER, PL/M8			4 500001-							
17	V401-160-008-00	WASHER, SP/M8			4 500001-							
18	V304-260-008-00	NUT/M8			4 500001-							
19	8663-201-057-10	PULLEY/V2B90			1 500001-							
20	8663-201-054-00	KEY/07X07X22			1 500001-							
21	8663-201-063-00	WASHER/11X30X03			1 500001-							
22	V304-260-010-00	NUT/M10			2 500001-							
23	V600-150-630-50	BEARING, RB/6305SS			2 500001-							
24	8674-201-004-00	COLLAR/25X34X30			1 500001-							
25	V707-140-062-00	RING, SNAP/R62			1 500001-							
26	8665-201-071-00	TUBE/137			1 500001-							
27	8663-201-510-50	ARM/TENSION ASSY			1 500001-							
28	2502-407-001-10	BUSH/15X17X11			2 500001-							
29	V401-160-006-00	WASHER, SP/M6			1 500001-							
30	V760-150-000-00	NIPPLE, GREASE			1 500001-							

FIG.005 PULLEY SYSTEM(SCMA54)(NO.500001-)

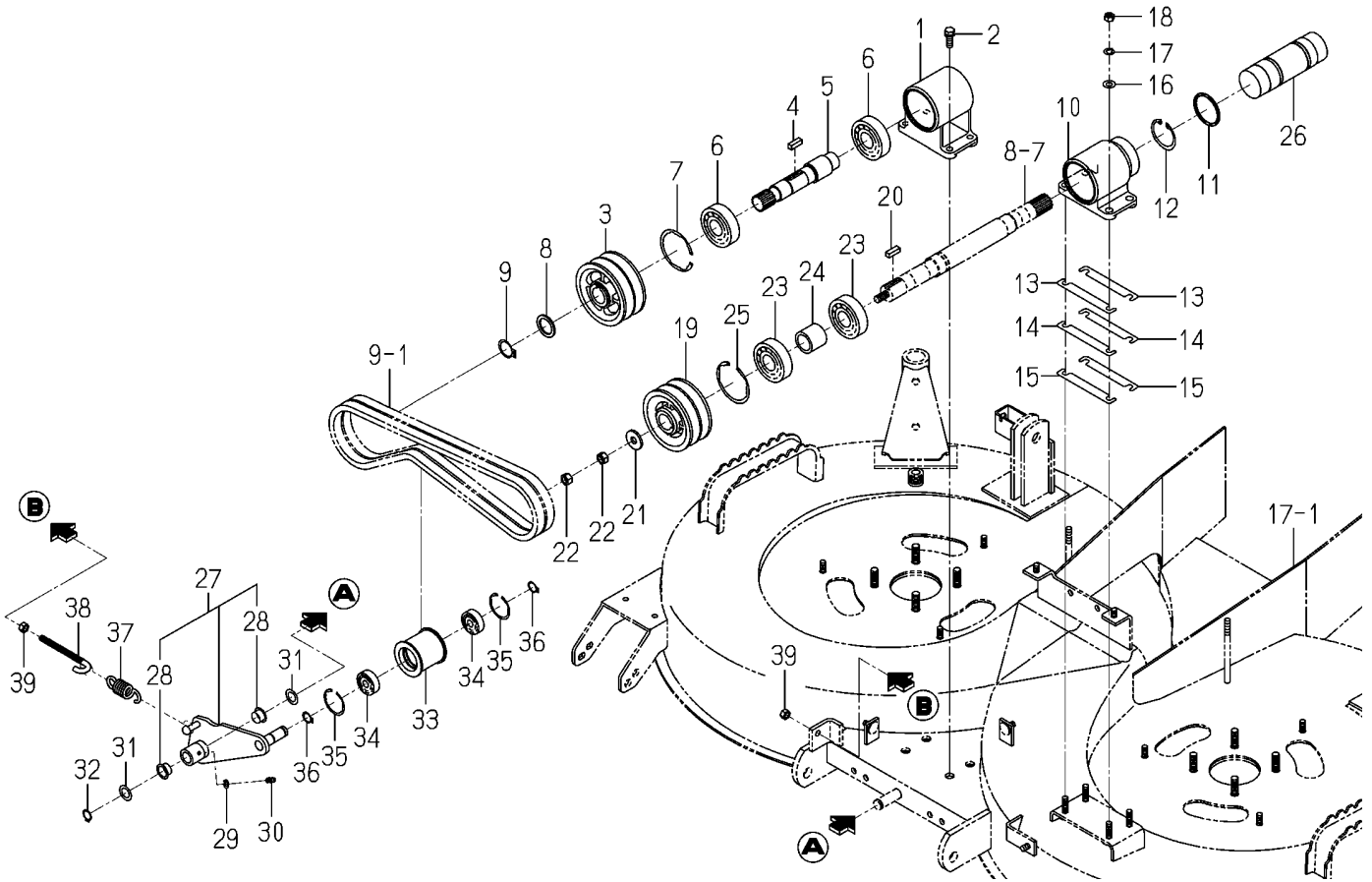

図番	部品コード	品名	仕様	型式					代替性	色番号	グループ	備考
				SCMA48 SXG22F	SCMA54 SXG22F							
31	3517-205-007-00	WASHER			2							
					500001-							
32	V704-140-015-00	RING, SNAP/15 C			1							
					500001-							
33	8663-201-062-10	PULLY/FT050X046			1							
					500001-							
34	V600-350-620-20	BEARING, RB/6202SS			2							
					500001-							
35	V705-140-035-00	RING, SNAP/35 C			2							
					500001-							
36	V704-140-015-00	RING, SNAP/15 C			2							
					500001-							
37	1337-401-006-00	SPRING			1							
					500001-							
38	3737-341-007-00	ROD, CHAIN TENSION			1							
					500001-							
39	V304-260-008-00	NUT/M8			2							
					500001-							

FIG.006 CASE(BEVEL)SYSTEM(SCMA48)

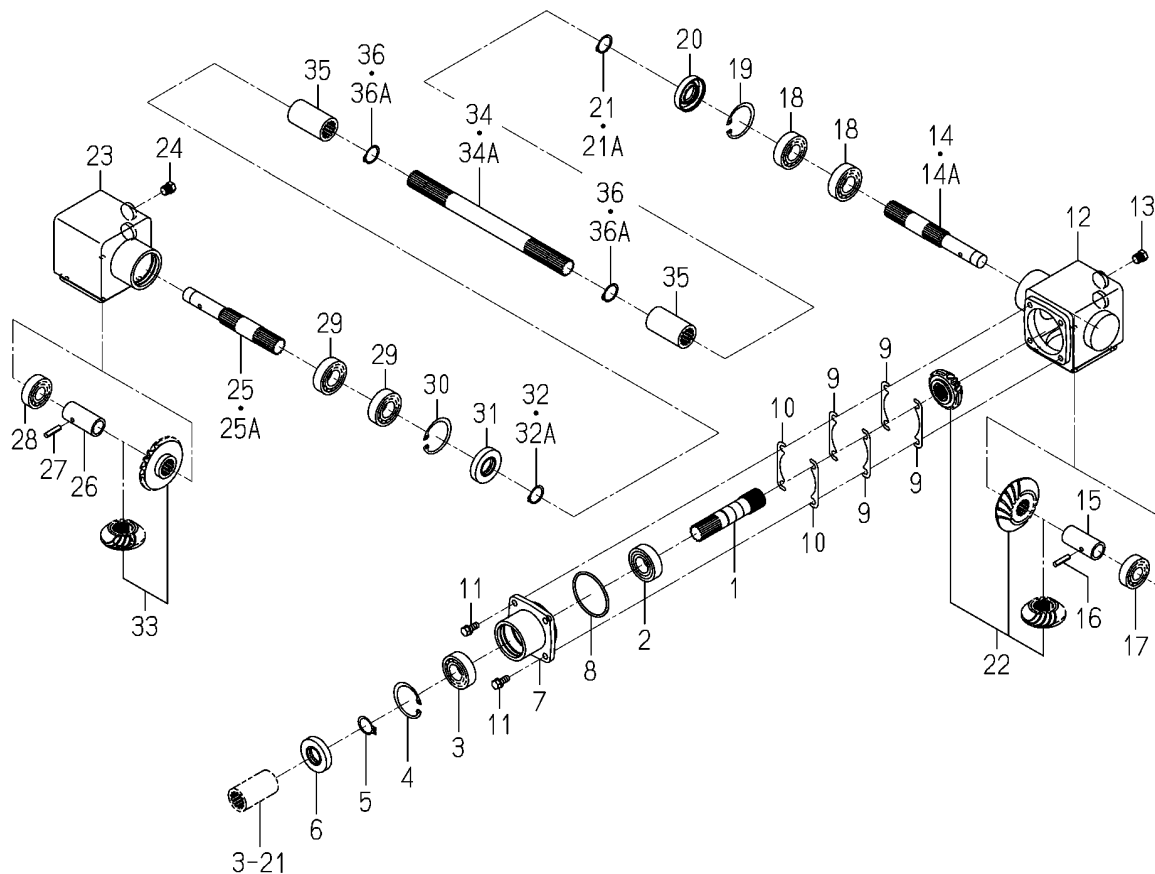

図番	部品コード	品名	仕様	型式				代替性	色番号	グループ	備考
				SCMA48 SXG22F	SCMA54 SXG22F						
1	8663-202-051-00	SHAFT/LH/REAR	*	1							
2	1594-221-001-00	BEARING/BALL 6205SH2	*	1							
3	V600-110-620-50	BEARING, RB/6205	*	1							
4	V705-140-052-00	RING, SNAP/52 C	*	1							
5	V704-140-025-00	RING, SNAP/25 C	*	1							
6	V744-125-521-00	SEAL, OIL/TC255210	*	1							
7	8663-202-052-10	METAL/BEVELCASE	*	1							
8	V721-103-106-50	O-RING/1A, G65	*	1							
9	8663-202-055-00	SHIM/0.1	*	4							
10	8663-202-056-00	SHIM/0.2	*	2							
11	V211-260-802-00	BOLT, S/M8X20	*	4							
12	8663-202-057-10	CASE/BEVEL/LH	*	1							
13	7955-201-026-00	PLUG, DRAIN (1/4)	*	2							
14	8663-202-058-00	SHAFT/CASE	*	1 -401340							
14A	8663-202-058-10	SHAFT/CASE	*	1 401341-							
15	8663-202-059-00	HUB/SPACER	*	1							
16	V580-140-602-80	PIN, SPRING/6X28 W	*	1							
17	V600-110-620-40	BEARING, RB/6204	*	1							
18	V600-110-620-50	BEARING, RB/6205	*	2							
19	V705-140-052-00	RING, SNAP/52 C	*	1							
20	V744-125-521-00	SEAL, OIL/TC255210	*	1							
21	V704-140-025-00	RING, SNAP/25 C	*	1 -401340							
21A	1725-218-006-00	RING/SNAP/CS25	*	1 401341-							
22	8663-202-610-00	GEAR/B/21-25-21 SET	*	1							
23	8663-202-062-10	CASE/BEVEL/RH	*	1				7F			
24	7955-201-026-00	PLUG, DRAIN (1/4)	*	2							
25	8663-202-058-00	SHAFT/CASE	*	1 -401340							
25A	8663-202-058-10	SHAFT/CASE	*	1 401341-							
26	8663-202-059-00	HUB/SPACER	*	1							
27	V580-140-602-80	PIN, SPRING/6X28 W	*	1							

FIG.006 CASE(BEVEL)SYSTEM(SCMA48)

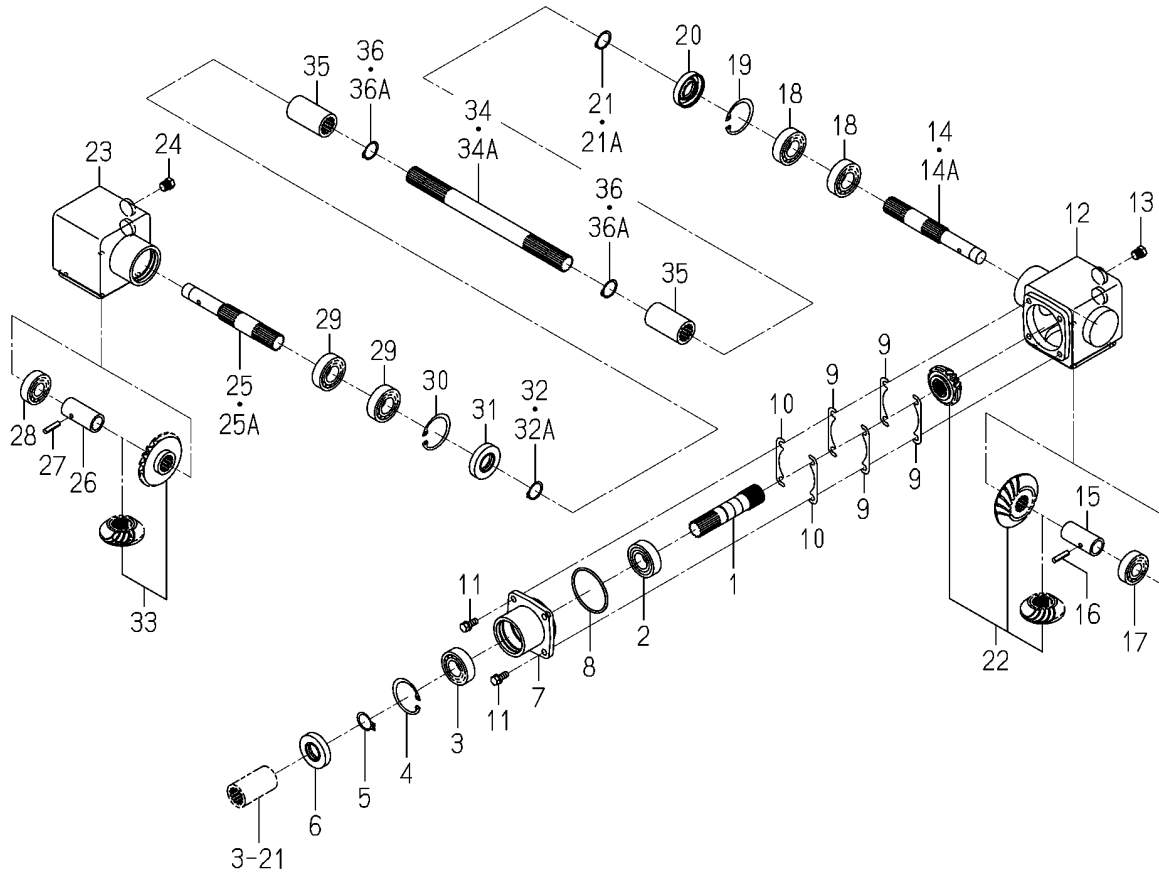

図番	部品コード	品名	仕様	型式				代替性	色番号	グループ	備考
				SCMA48 SXG22F	SCMA54 SXG22F						
28	V600-110-620-40	BEARING, RB/6204	*	1							
29	V600-110-620-50	BEARING, RB/6205	*	2							
30	V705-140-052-00	RING, SNAP/52 C	*	1							
31	V744-125-521-00	SEAL, OIL/TC255210	*	1							
32	V704-140-025-00	RING, SNAP/25 C	*	1							
32A	1725-218-006-00	RING/SNAP/CS25	*	1							
33	8663-202-620-00	GEAR/BEVEL/25-2 SET	*	1							
34	8663-202-061-00	SHAFT/CENTER/48	*	1							
34A	8663-202-061-10	SHAFT/CENTER/48	*	1							
35	1560-220-004-10	COUPLING/21X36X65	*	2							
36	V704-140-025-00	RING, SNAP/25 C	*	2							
36A	1725-218-006-00	RING/SNAP/CS25	*	2							

FIG.007 CASE(BEVEL)SYSTEM(SCMA54)(NO.1-400725)

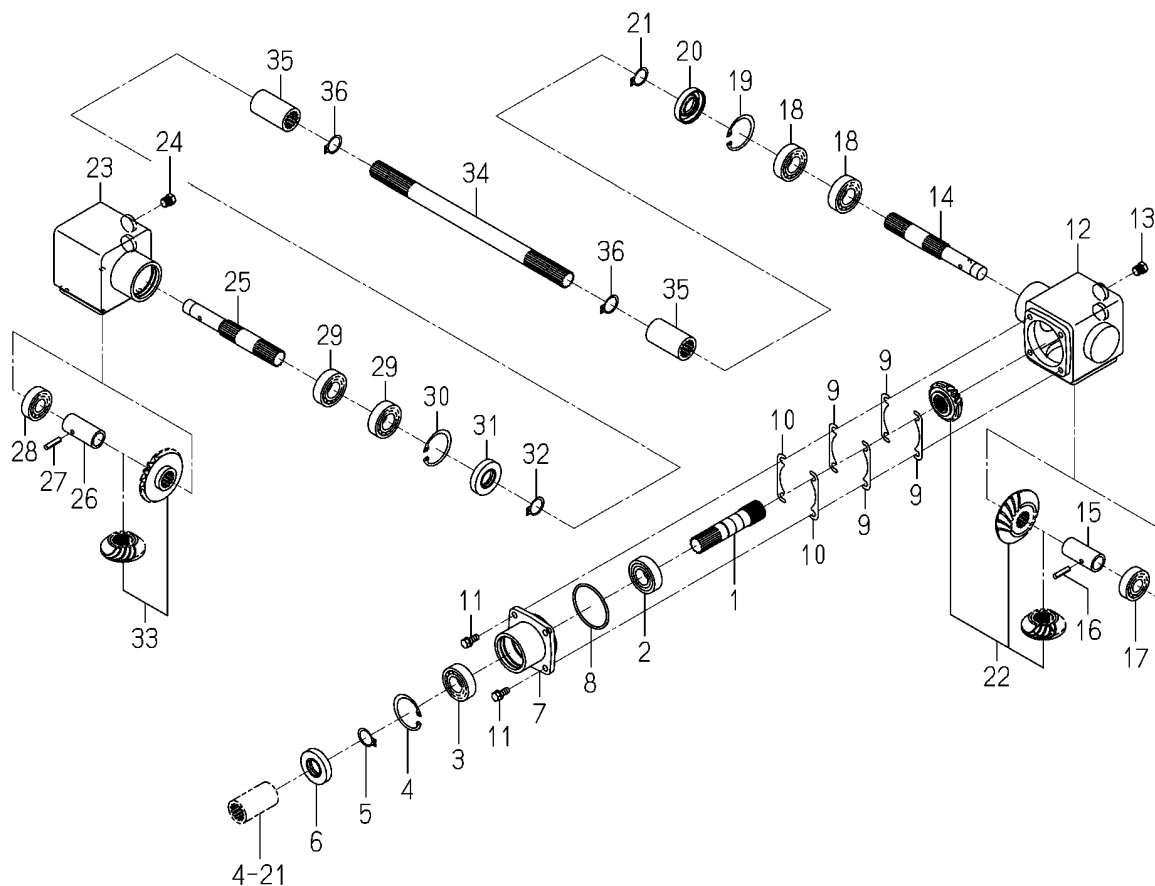

図番	部品コード	品名	仕様	型式				代替性	色番号	グループ	備考
				SCMA48 SXG22F	SCMA54 SXG22F						
1	8663-202-051-00	SHAFT/LH/REAR			1 -400725						
2	1594-221-001-00	BEARING/BALL 6205SH2			1 -400725						
3	V600-110-620-50	BEARING, RB/6205			1 -400725						
4	V705-140-052-00	RING, SNAP/52 C			1 -400725						
5	V704-140-025-00	RING, SNAP/25 C			1 -400725						
6	V744-125-521-00	SEAL, OIL/TC255210			1 -400725						
7	8663-202-052-10	METAL/BEVELCASE			1 -400725						
8	V721-103-106-50	O-RING/1A, G65			1 -400725						
9	8663-202-055-00	SHIM/0.1			4 -400725						
10	8663-202-056-00	SHIM/0.2			2 -400725						
11	V211-260-802-00	BOLT, S/M8X20			4 -400725						
12	8663-202-057-10	CASE/BEVEL/LH			1 -400725						
13	7955-201-026-00	PLUG, DRAIN (1/4)			2 -400725						
14	8663-202-058-00	SHAFT/CASE			1 -400725						
15	8663-202-059-00	HUB/SPACER			1 -400725						
16	V580-140-602-80	PIN, SPRING/6X28 W			1 -400725						
17	V600-110-620-40	BEARING, RB/6204			1 -400725						
18	V600-110-620-50	BEARING, RB/6205			2 -400725						
19	V705-140-052-00	RING, SNAP/52 C			1 -400725						
20	V744-125-521-00	SEAL, OIL/TC255210			1 -400725						
21	V704-140-025-00	RING, SNAP/25 C			1 -400725						
22	8663-202-610-00	GEAR/B/21-25-21 SET			1 -400725						
23	8663-202-062-10	CASE/BEVEL/RH			1 -400725			7F			
24	7955-201-026-00	PLUG, DRAIN (1/4)			2 -400725						
25	8663-202-058-00	SHAFT/CASE			1 -400725						
26	8663-202-059-00	HUB/SPACER			1 -400725						
27	V580-140-602-80	PIN, SPRING/6X28 W			1 -400725						
28	V600-110-620-40	BEARING, RB/6204			1 -400725						
29	V600-110-620-50	BEARING, RB/6205			2 -400725						
30	V705-140-052-00	RING, SNAP/52 C			1 -400725						

FIG.007 CASE(BEVEL)SYSTEM(SCMA54)(NO.1-400725)

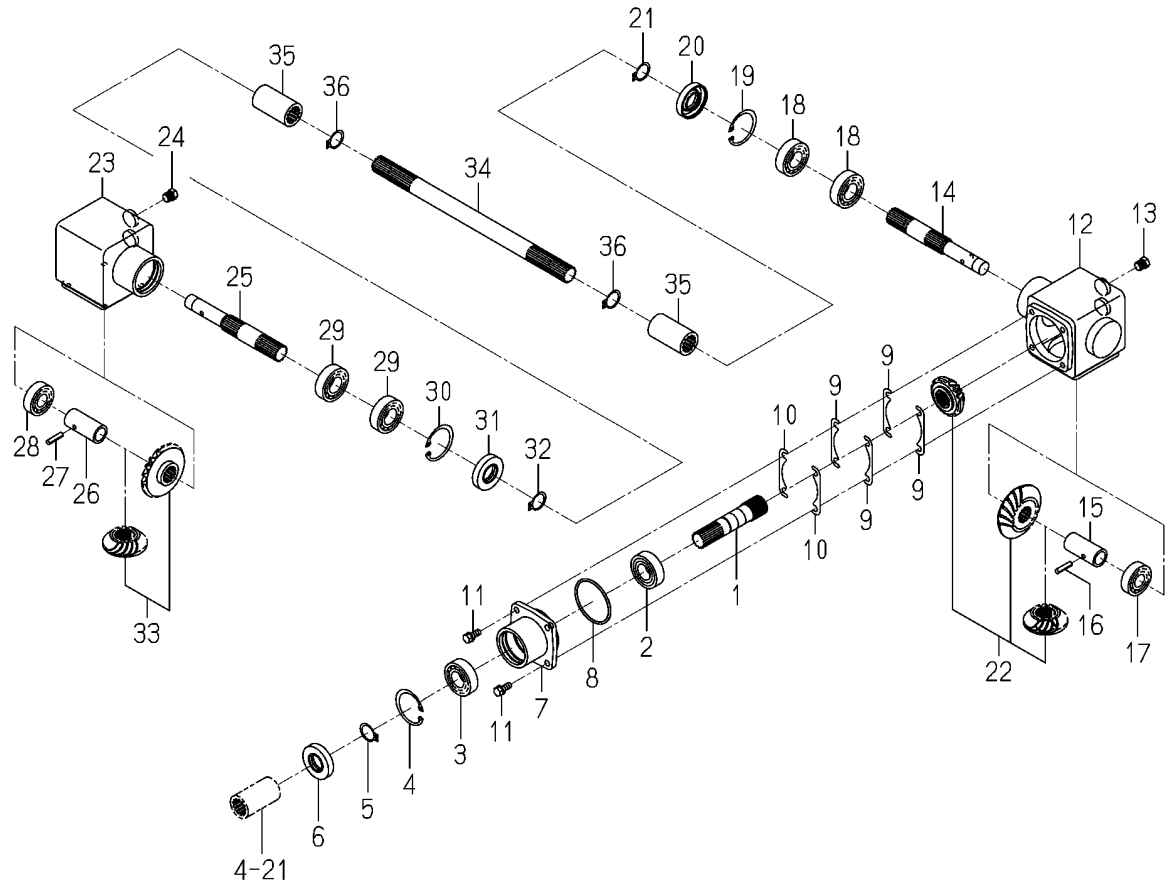

図番	部品コード	品名	仕様	型式					代替性	色番号	グループ	備考
				SCMA48 SXG22F	SCMA54 SXG22F							
31	V744-125-521-00	SEAL, OIL/TC255210			1							
32	V704-140-025-00	RING, SNAP/25 C			-400725							
33	8663-202-620-00	GEAR/BEVEL/25-2 SET			1							
34	8665-202-051-00	SHAFT/CENTER/54			-400725							
35	1560-220-004-10	COUPRING/21X36X65			1							
36	V704-140-025-00	RING, SNAP/25 C			2							
					-400725							
					2							
					-400725							

FIG.008 CASE(BEVEL)SYSTEM(SCMA54)(NO.500001-)

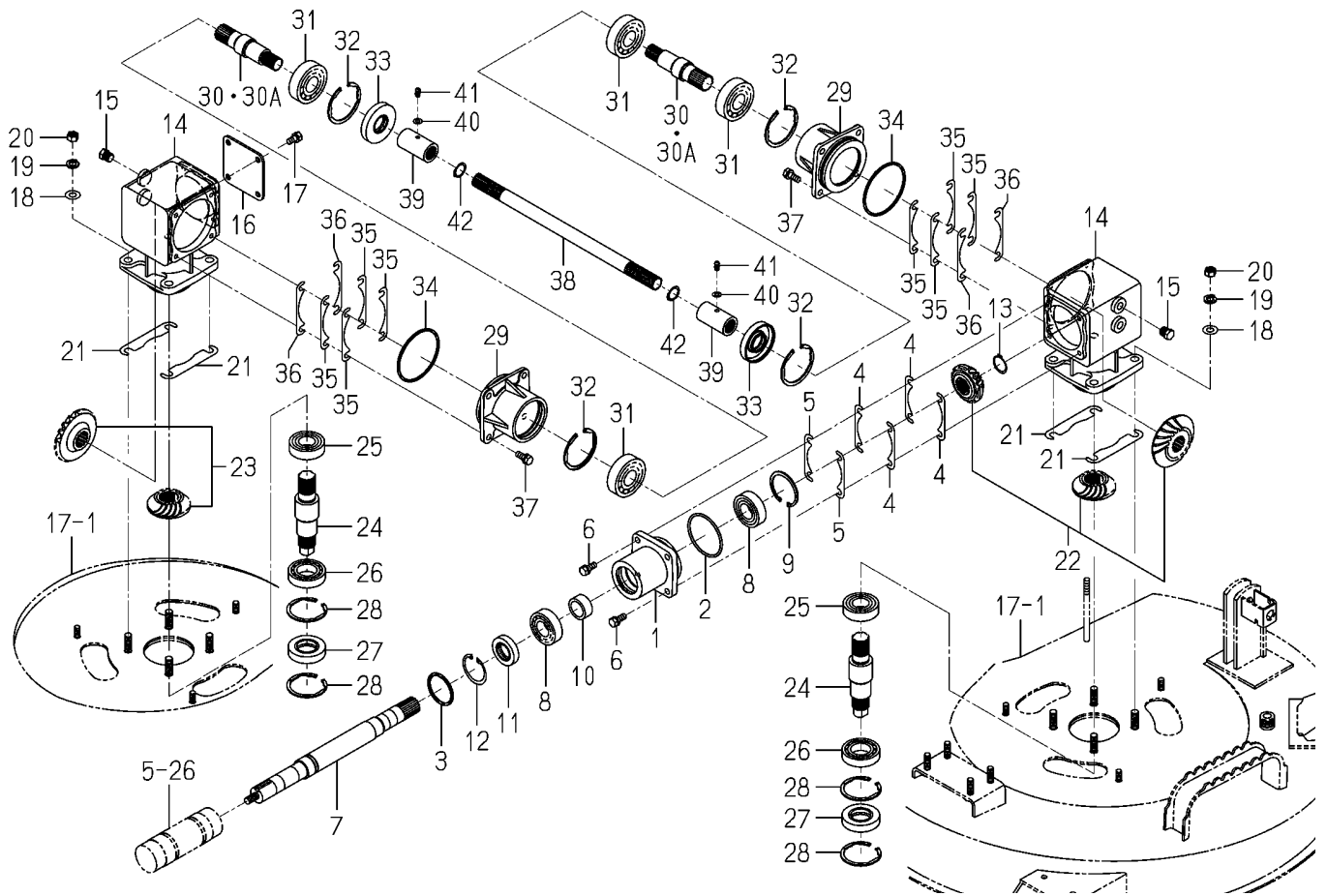

図番	部品コード	品名	仕様	型式				代替性	色番号	グループ	備考
				SCMA48 SXG22F	SCMA54 SXG22F						
1	8674-202-001-20	METAL/CASE			1 500001-						
2	V721-103-106-50	O-RING/1A, G65			1 500001-						
3	V720-103-504-40	O-RING/1A, P44			1 500001-						
4	8663-202-055-00	SHIM/O. 1			4 500001-						
5	8663-202-056-00	SHIM/O. 2			2 500001-						
6	V211-560-802-00	BOLT, S/M8X20/7T			4 500001-						
7	8665-202-071-00	SHAFT/LH/54			1 500001-						
8	1594-221-001-00	BEARING/BALL 6205SH2			2 500001-						
9	V705-140-052-00	RING, SNAP/52 C			1 500001-						
10	8674-202-003-00	COLLAR/25X34X15			1 500001-						
11	V744-128-451-10	SEAL, OIL/TC284511			1 500001-						
12	V705-140-045-00	RING, SNAP/45 C			1 500001-						
13	V704-140-025-00	RING, SNAP/25 C			1 500001-						
14	8674-202-004-00	CASE/BEVEL			2 500001-						
15	7955-201-026-00	PLUG, DRAIN (1/4)			4 500001-						
16	8674-202-006-00	COVER/CASE			1 500001-						
17	V211-260-801-60	BOLT, S/M8X16			4 500001-						
18	V411-260-010-00	WASHER, PL/M10			8 500001-						
19	V401-160-010-00	WASHER, SP/M10			8 500001-						
20	V304-260-010-00	NUT/M10			8 500001-						
21	8670-201-005-10	SHIM/O. 2			4 500001-						
22	8674-202-210-00	GEAR/B/21-25-21 SET			1 500001-						
23	8674-202-220-00	GEAR/BEVEL/25-2 SET			1 500001-						
24	8674-202-007-00	SHAFT/BLADE			2 500001-						
25	1594-221-001-00	BEARING/BALL 6205SH2			2 500001-						
26	V600-110-600-60	BEARING, RB/6006			2 500001-						
27	V744-130-551-20	SEAL, OIL/TC305512			2 500001-						
28	V707-140-055-00	RING, SNAP/R55			4 500001-						
29	8667-201-002-02	METAL/INPUT			2 500001-				7F		
30	8674-202-009-00	SHAFT/CASE			2 500001-						

FIG.008 CASE(BEVEL)SYSTEM(SCMA54)(NO.500001-)

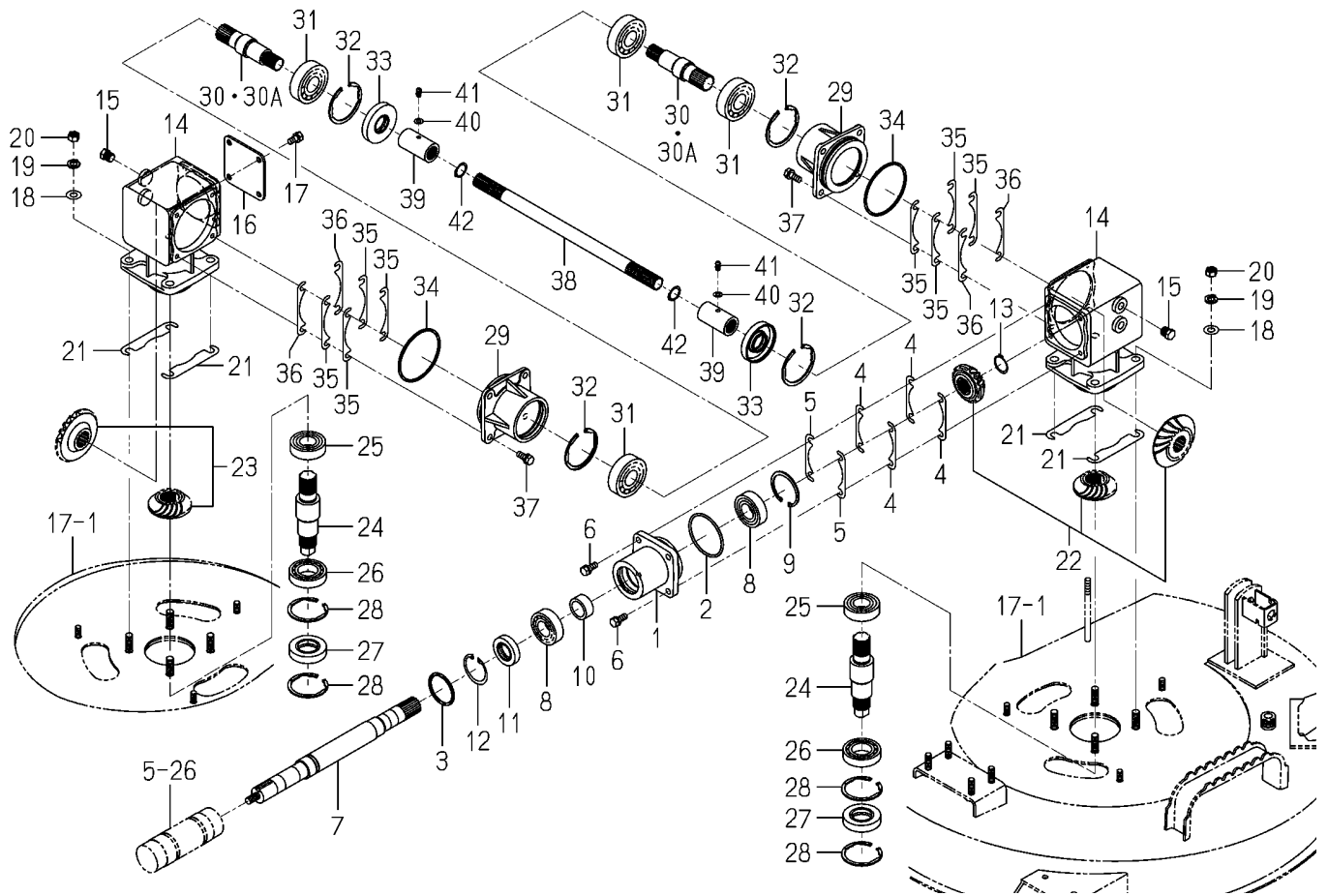

図番	部品コード	品名	仕様	型式					代替性	色番号	グループ	備考
				SCMA48 SXG22F	SCMA54 SXG22F							
30A	8674-202-009-10	SHAFT/CASE			2 500484-							
31	1594-218-001-00	BEARING/BALL 6305SH2			4 500001-							
32	V707-140-062-00	RING, SNAP/R62			4 500001-							
33	8595-201-025-00	SEAL/OIL			2 500001-							
34	V721-103-108-00	O-RING/1A, G80			2 500001-							
35	8595-201-021-00	SHIM/O. 1			8 500001-							
36	8595-201-022-00	SHIM/O. 2			4 500001-							
37	V211-560-802-00	BOLT, S/M8X20/7T			8 500001-							
38	8665-202-073-00	SHAFT/JOINT/54			1 500001-							
39	1782-122-051-00	COUPLING/18X30X55			2 500001-			7F				
40	V411-260-006-00	WASHER, PL/M6			2 500001-							
41	V760-150-000-00	NIPPLE, GREASE			2 500001-							
42	8674-202-012-00	RING/SNAP/CS20			2 500001-							

FIG.009 BELT SYSTEM(SCMA54)(NO.500001-)

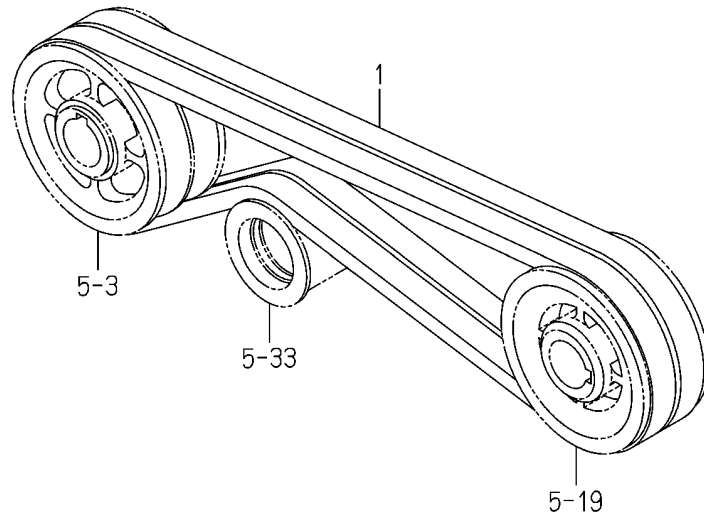

図番	部品コード	品名	仕様	型式				代替性	色番号	グループ	備考
				SCMA48 SXG22F	SCMA54 SXG22F						
1	8665-203-700-00	BELT/VCOGB038 SET			1 500001-						

FIG.010 COLLAR(BRADE)SYSTEM (SCMA54)(NO.500001-)

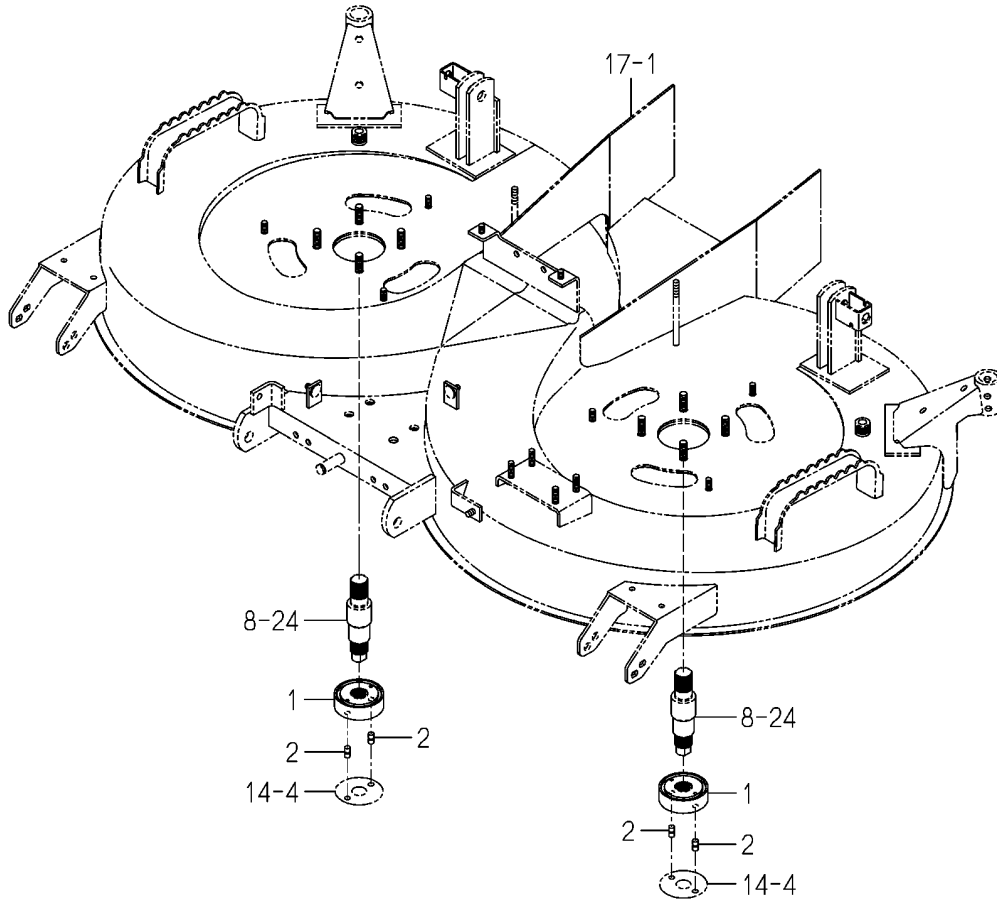

図番	部品コード	品名	仕様	型式				代替性	色番号	グループ	備考
				SCMA48 SXG22F	SCMA54 SXG22F						
1	8674-301-001-00	COLLAR/BLADE			2						
2	8670-301-002-10	PIN/08X16			500001-	4					
					500001-						

FIG.011 METAL SYSTEM(NO.1-400725)

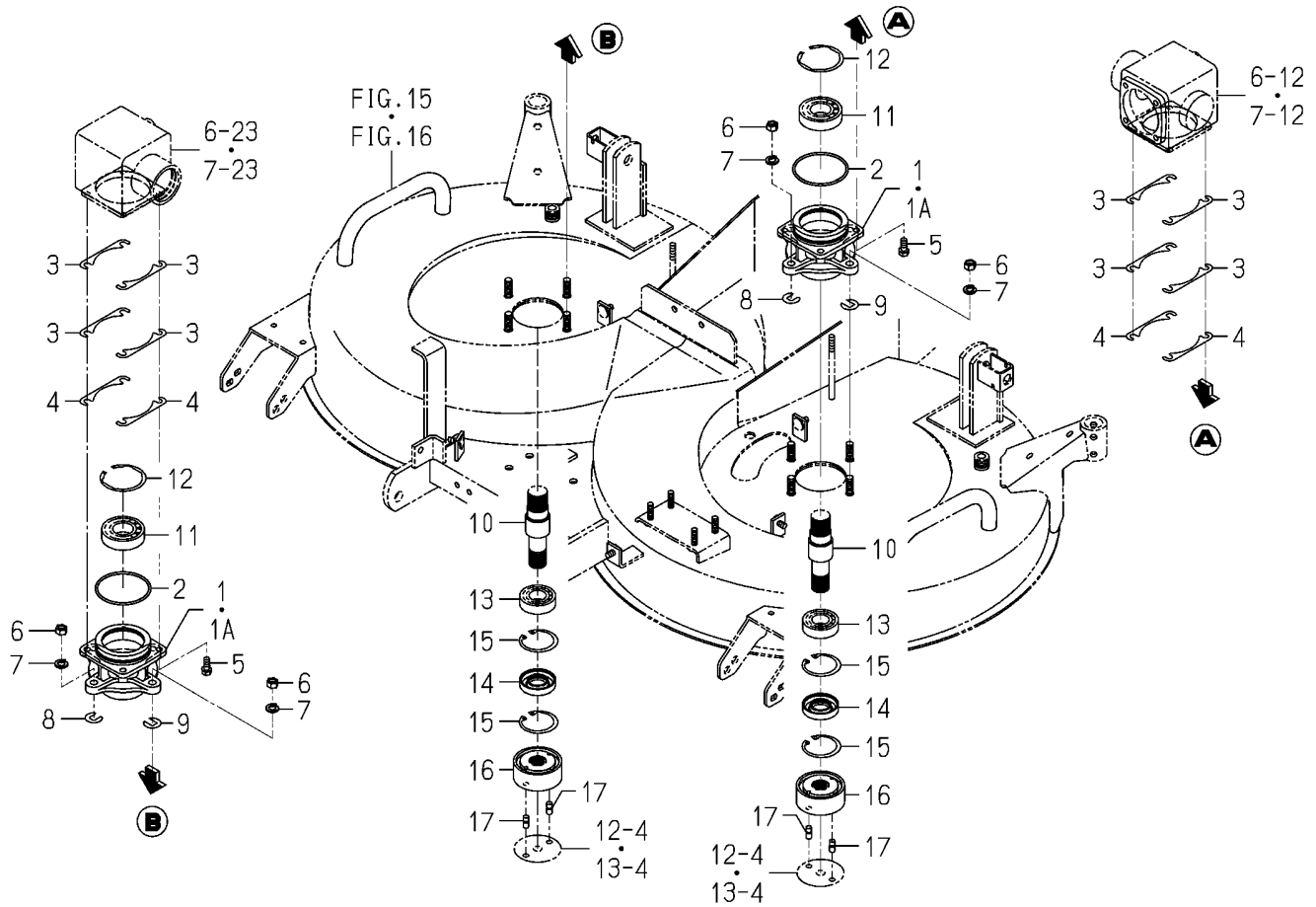

図番	部品コード	品名	仕様	型式				代替性	色番号	グループ	備考
				SCMA48 SXG22F	SCMA54 SXG22F						
1	8663-301-051-20	METAL/BLADE/B	*	2 -401174	2 -400325						
1A	8663-301-051-30	METAL/BLADE/B	*	2 401175-	2 -400725						
2	V721-103-107-50	O-RING/1A, G75	*	2	2 -400725						
3	8595-201-021-00	SHIM/O. 1	*	8	8 -400725						
4	8595-201-022-00	SHIM/O. 2	*	8	8 -400725						
5	V211-260-802-00	BOLT, S/M8X20	*	8	8 -400725						
6	V304-260-010-00	NUT/M10	*	8	8 -400725						
7	V401-160-010-00	WASHER, SP/M10	*	8	8 -400725						
8	2120-340-003-00	SHIM, PLANTING A/O. 1	*	2 401162-	2 -400725						
9	2120-340-004-00	SHIM, PLANTING B/O. 5	*	4 401162-	4 -400725						
10	8663-301-052-10	SHAFT/BLADE/B	*	2	2 -400725						
11	V600-110-620-60	BEARING, RB/6206	*	2	2 -400725						
12	V707-140-062-00	RING, SNAP/R62	*	2	2 -400725						
13	V600-110-620-50	BEARING, RB/6205	*	2	2 -400725						
14	V744-125-521-00	SEAL, OIL/TC255210	*	2	2 -400725						
15	V705-140-052-00	RING, SNAP/52 C	*	4	4 -400725						
16	8663-301-053-10	COLLAR/BLADE	*	2	2 -400725						
17	8663-301-004-00	PIN/08X18	*	4	4 -400725						

FIG.012 BLADE SYSTEM(SCMA48)

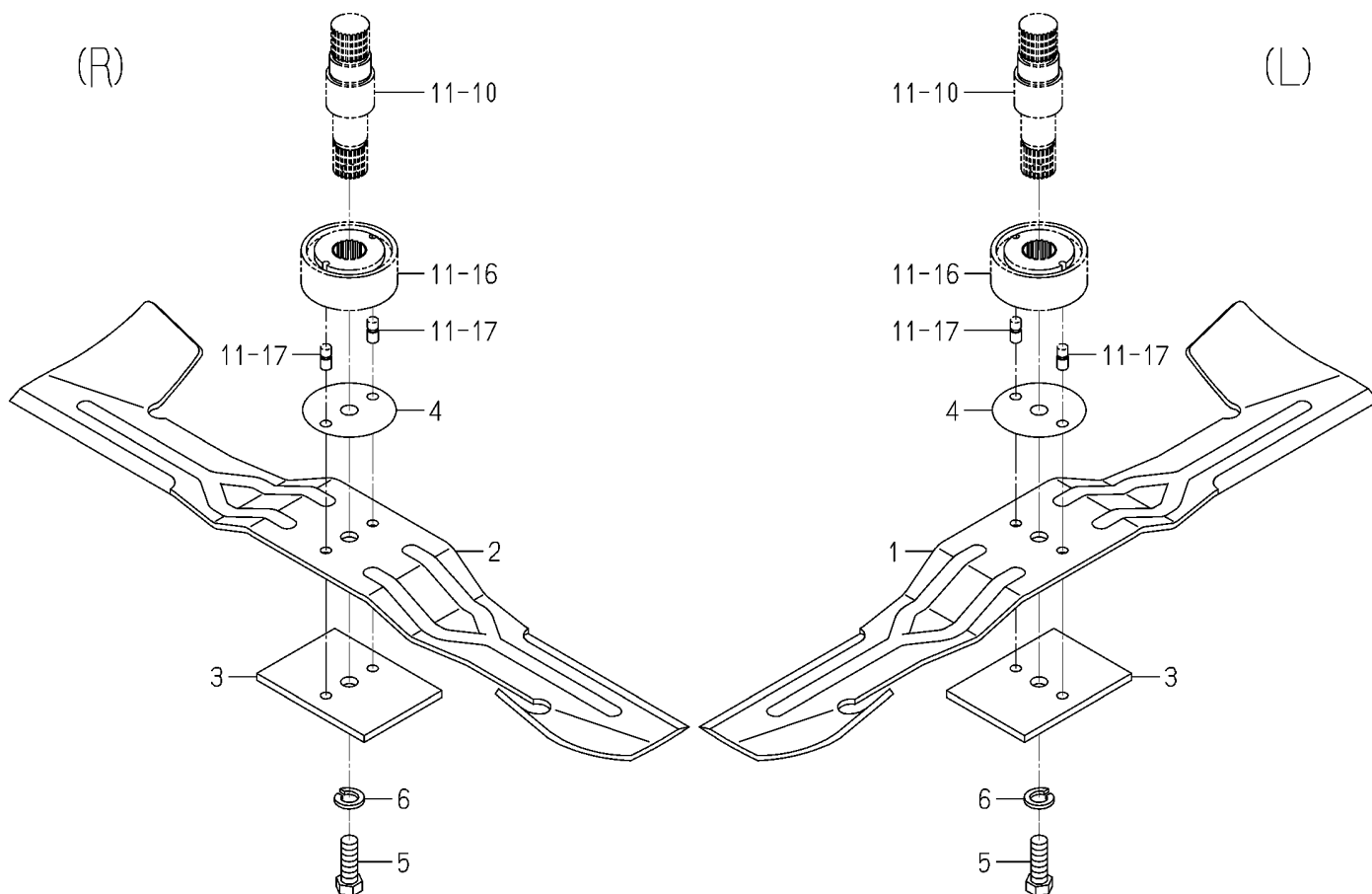

図番	部品コード	品名	仕様	型式				代替性	色番号	グループ	備考
				SCMA48 SXG22F	SCMA54 SXG22F						
1	8663-306-001-10	BLADE/60X640/C	*	1							
2	8663-306-002-10	BLADE/60X640/D	*	1							
3	8663-306-210-10	PLATE/I/80X110 COMP	*	2							
4	8663-306-004-00	SHIM/1.2	*	2							
5	V203-361-203-50	BOLT/M12X35/7T, P1. 25	*	2							
6	V401-160-012-00	WASHER, SP/M12	*	2							

FIG.013 BLADE SYSTEM(SCMA54)(NO.1-400725)

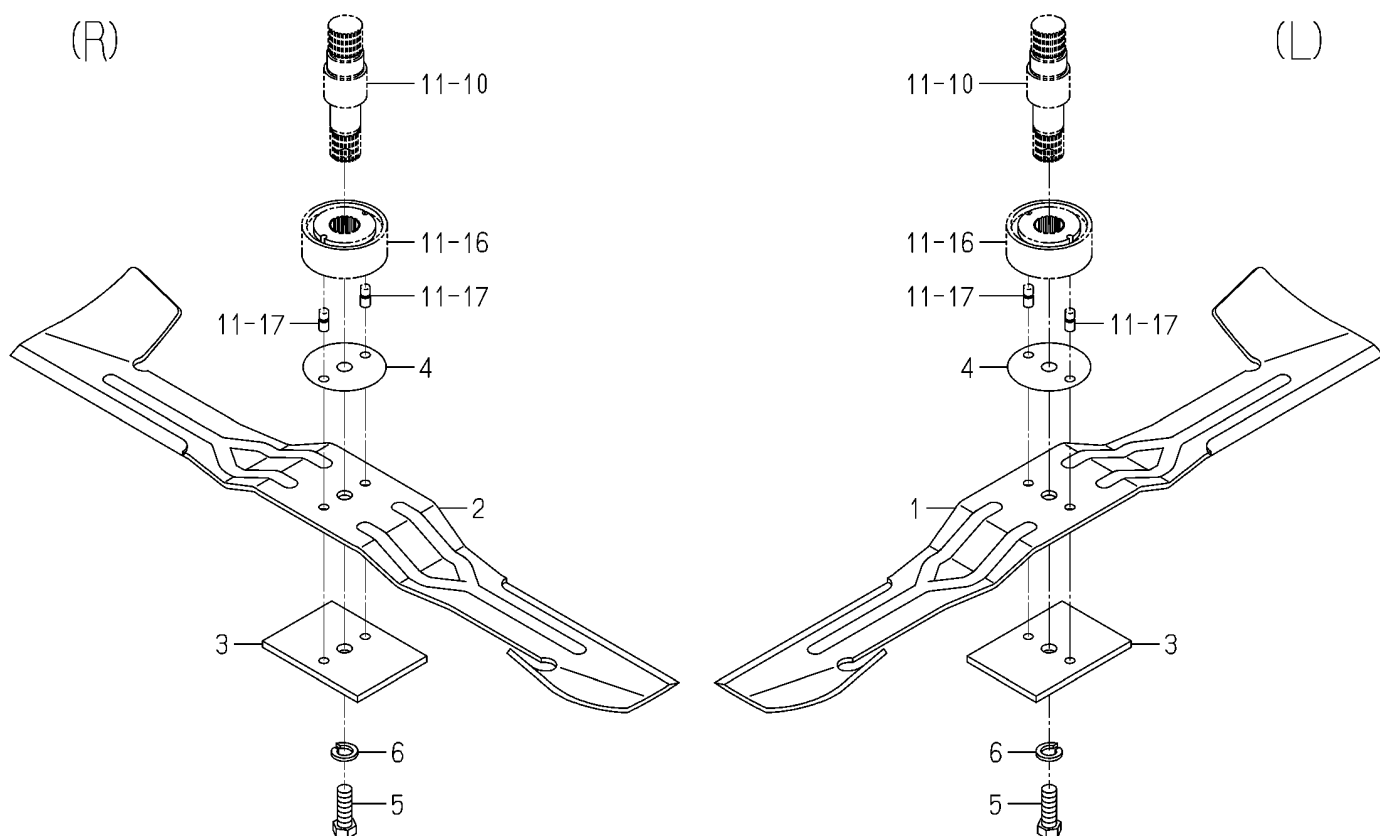

図番	部品コード	品名	仕様	型式					代替性	色番号	グループ	備考
				SCMA48 SXG22F	SCMA54 SXG22F							
1	8665-306-001-10	BLADE/60X716/C			1 -400725							
2	8665-306-002-10	BLADE/60X716/D			1 -400725							
3	8663-306-210-10	PLATE/I/80X110 COMP			2 -400725							
4	8663-306-004-00	SHIM/1.2			2 -400725							
5	V203-361-203-50	BOLT/M12X35/7T, P1. 25			2 -400725							
6	V401-160-012-00	WASHER, SP/M12			2 -400725							

FIG.014 BLADE SYSTEM(SCMA54)(NO.500001-)

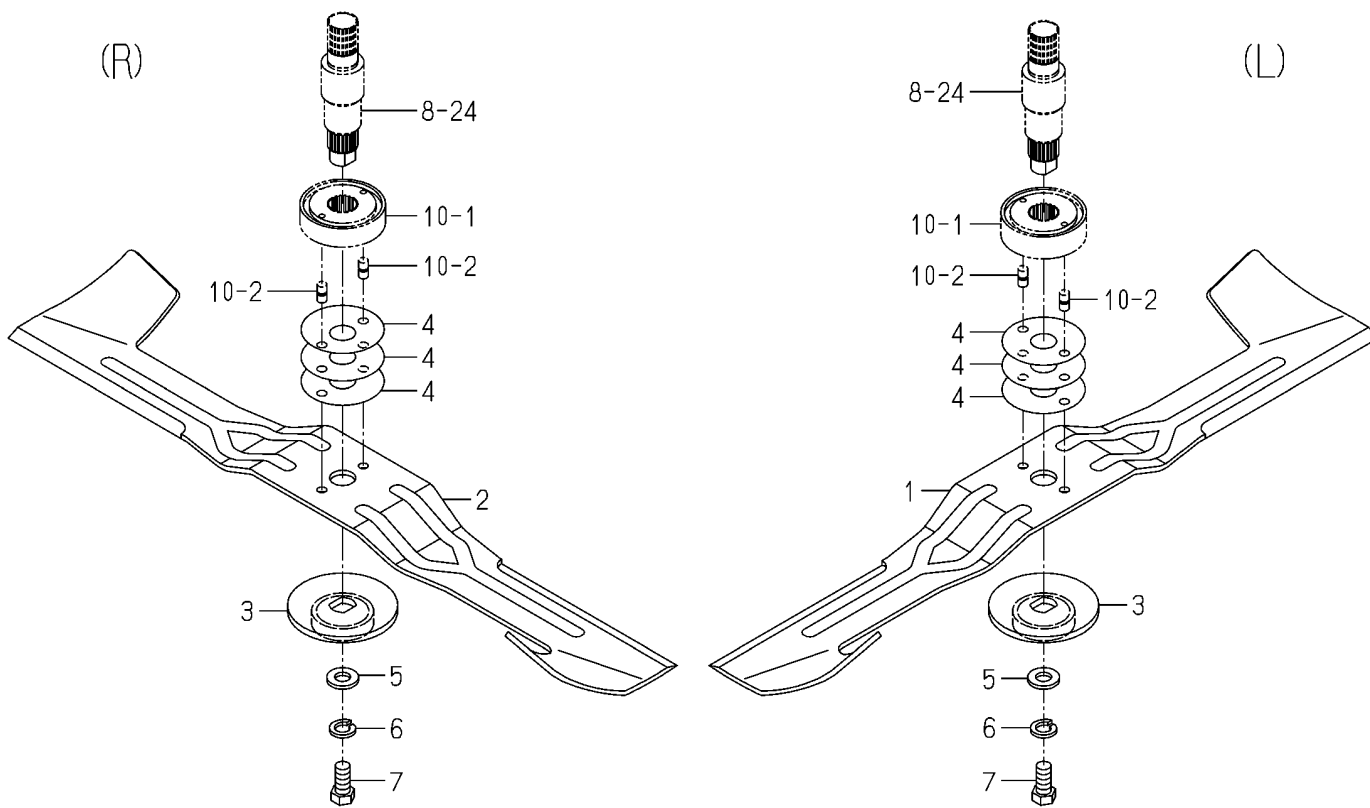

図番	部品コード	品名	仕様	型式				代替性	色番号	グループ	備考
				SCMA48 SXG22F	SCMA54 SXG22F						
1	8665-306-071-00	BLADE/60X716/E			1 500001-						
2	8665-306-072-00	BLADE/60X716/F			1 500001-						
3	8674-306-210-00	PLATE/BLADE COMP			2 500001-						
4	8674-306-003-00	SHIM/1.2			6 500001-						
5	8674-306-004-00	WASHER/11X22X03			2 500001-						
6	V401-160-012-00	WASHER, SP/M12			2 500001-						
7	V203-361-202-50	BOLT/M12X25/7T, P1.25			2 500001-						

FIG.015 DECK(MOWER)SYSTEM(SCMA48)

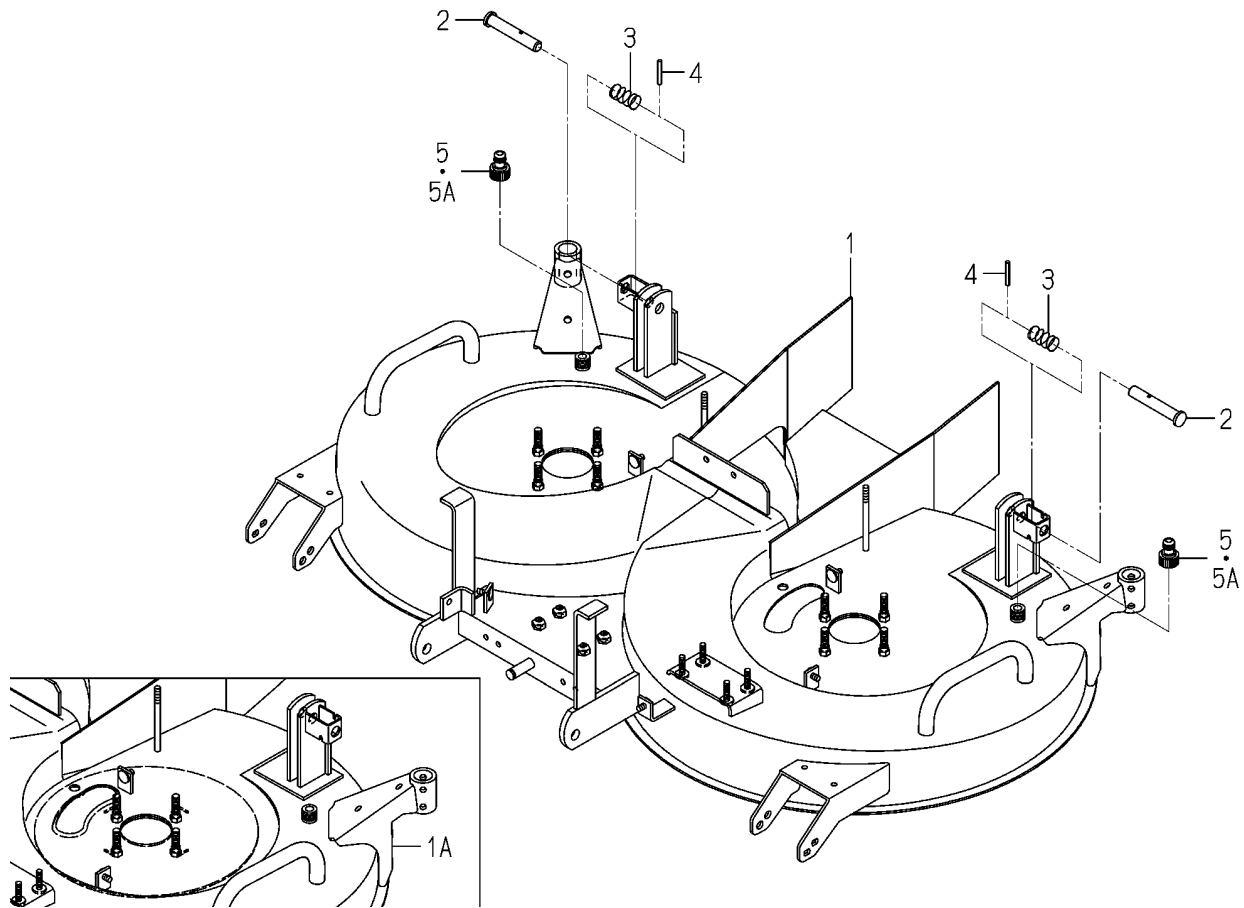

図番	部品コード	品名	仕様	型式					代替性	色番号	グループ	備考
				SCMA48 SXG22F	SCMA54 SXG22F							
1	8663-402-510-30	DECK/MOWER/48/B COMP	*	1 -401287						7F		
1A	8663-402-510-40	DECK/MOWER/48/B COMP	*	1 401288-						7F		
2	8595-608-082-10	PIN/16X96	*	2								
3	1560-601-028-00	SPRING/HCO42	*	2								
4	V580-140-504-00	PIN, SPRING/5X40 W	*	2								
5	8663-402-002-00	PLUG/HOSE/A	*	2 -400304								
5A	8663-402-002-10	PLUG/HOSE	*	2 400305-								

FIG.016 DECK(MOWER)SYSTEM (SCMA54)(NO.1-400725)

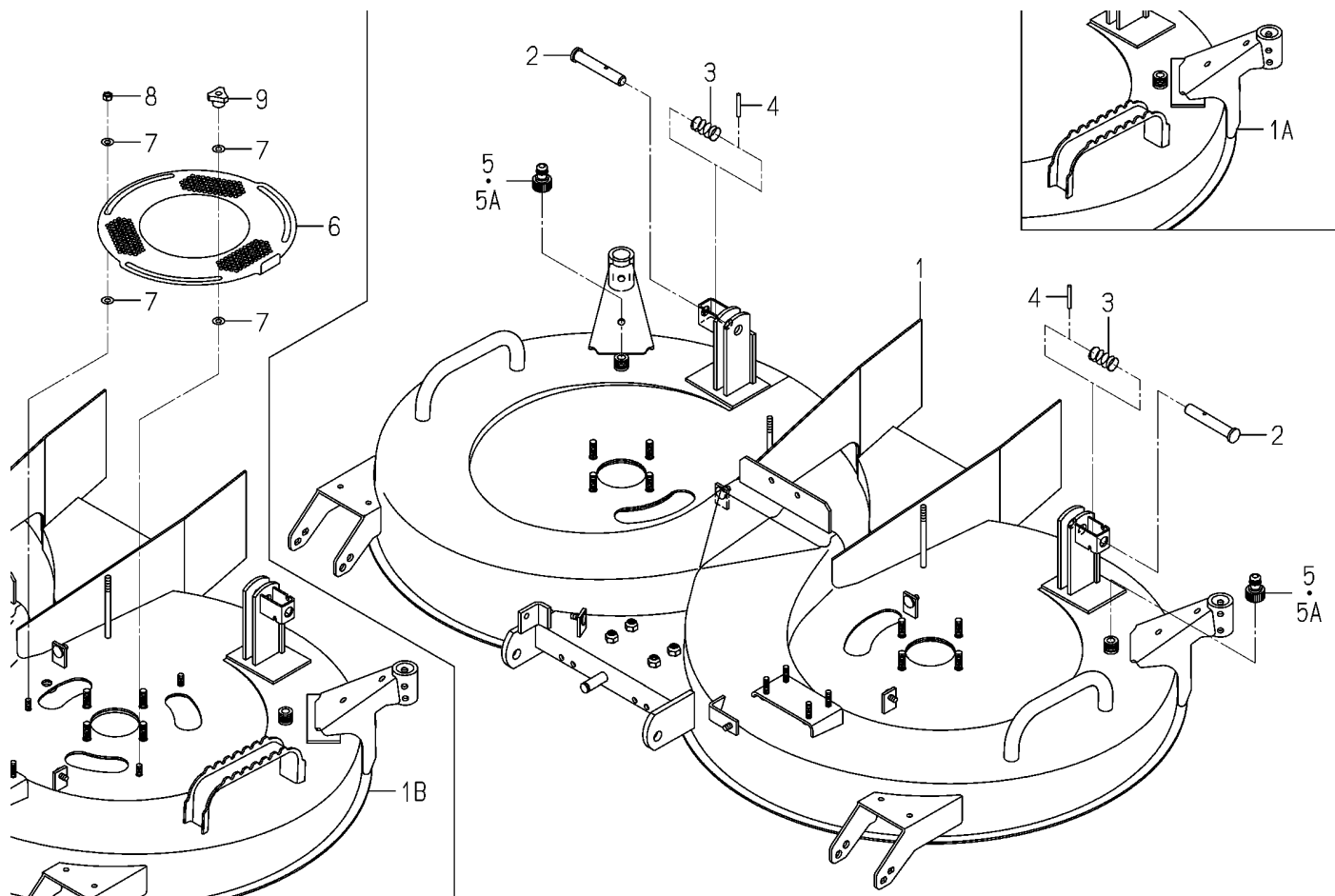

図番	部品コード	品名	仕様	型式				代替性	色番号	グループ	備考
				SCMA48 SXG22F	SCMA54 SXG22F						
1	8665-402-510-30	DECK/MOWER/54/B COMP			1				7F		
1A	8665-402-510-40	DECK/MOWER/54/B COMP			-400353				7F		
1B	8665-402-510-60	DECK/MOWER/54/B COMP			-400456				7F		
2	8595-608-082-10	PIN/16X96			2						
3	1560-601-028-00	SPRING/HCO42			-400725						
4	V580-140-504-00	PIN, SPRING/5X40 W			2						
5	8663-402-002-00	PLUG/HOSE/A			-400092						
5A	8663-402-002-10	PLUG/HOSE			2						
6	8674-402-001-00	COVER/METAL			-400725						
7	V411-260-008-00	WASHER, PL/M8			12						
8	1719-312-001-00	U-NUT			4						
9	3256-702-002-00	NUT, KNOB			2						
					-400725						

FIG.017 DECK(MOWER)SYSTEM (SCMA54)(NO.500001-)

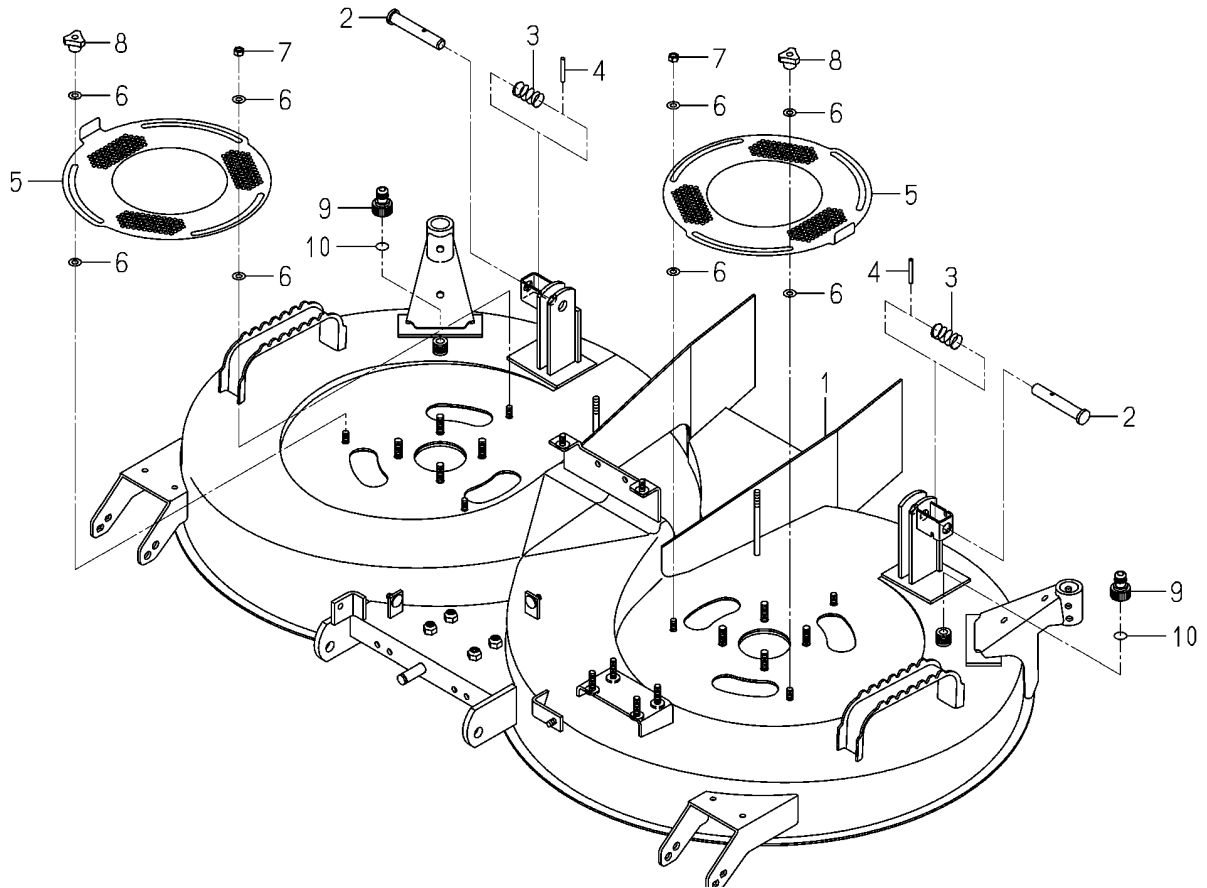

図番	部品コード	品名	仕様	型式					代替性	色番号	グループ	備考
				SCMA48 SXG22F	SCMA54 SXG22F							
1	8665-402-710-00	DECK/MOWER/54/326			1 500001-							
2	8595-608-082-10	PIN/16X96			2 500001-				7F			
3	1560-601-028-00	SPRING/HCO42			2 500001-							
4	V580-140-504-00	PIN, SPRING/5X40 W			2 500001-							
5	8674-402-001-00	COVER/METAL			2 500001-							
6	V411-260-008-00	WASHER, PL/M8			12 500001-							
7	1719-312-001-00	U-NUT			4 500001-							
8	3256-702-002-00	NUT, KNOB			2 500001-							
9	8663-402-002-10	PLUG/HOSE			2 500001-							
10	8674-402-002-00	PLATE/PIPE			2 501159-							

FIG.018 COVER(DISCHARGE)SYSTEM(SCMA48)

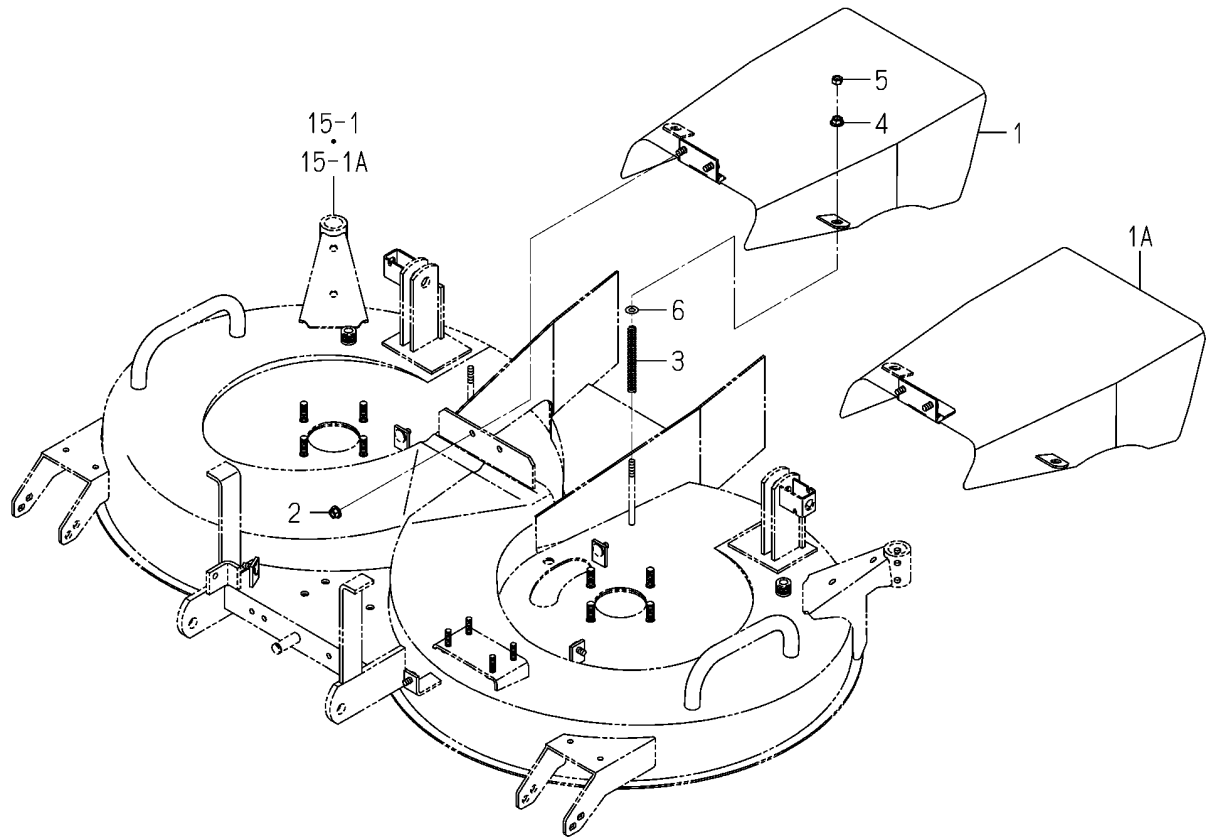

図番	部品コード	品名	仕様	型式					代替性	色番号	グループ	備考
				SCMA48 SXG22F	SCMA54 SXG22F							
1	8663-406-510-00	COVER/DISCHARGE/B	*	1						7F		
1A	8663-406-510-10	COVER/DISCHARGE/B	*	-401290						7F		
2	V363-260-008-00	NUT/WASHER/M8	*	1								
3	8663-406-001-00	SPRING/HC110	*	401291-								
4	V363-260-008-00	NUT/WASHER/M8	*	2								
5	V304-260-008-00	NUT/M8	*	2								
6	V411-260-008-00	WASHER, PL/M8	*	2								

FIG.019 COVER(DISCHARGE)SYSTEM(SCMA54)

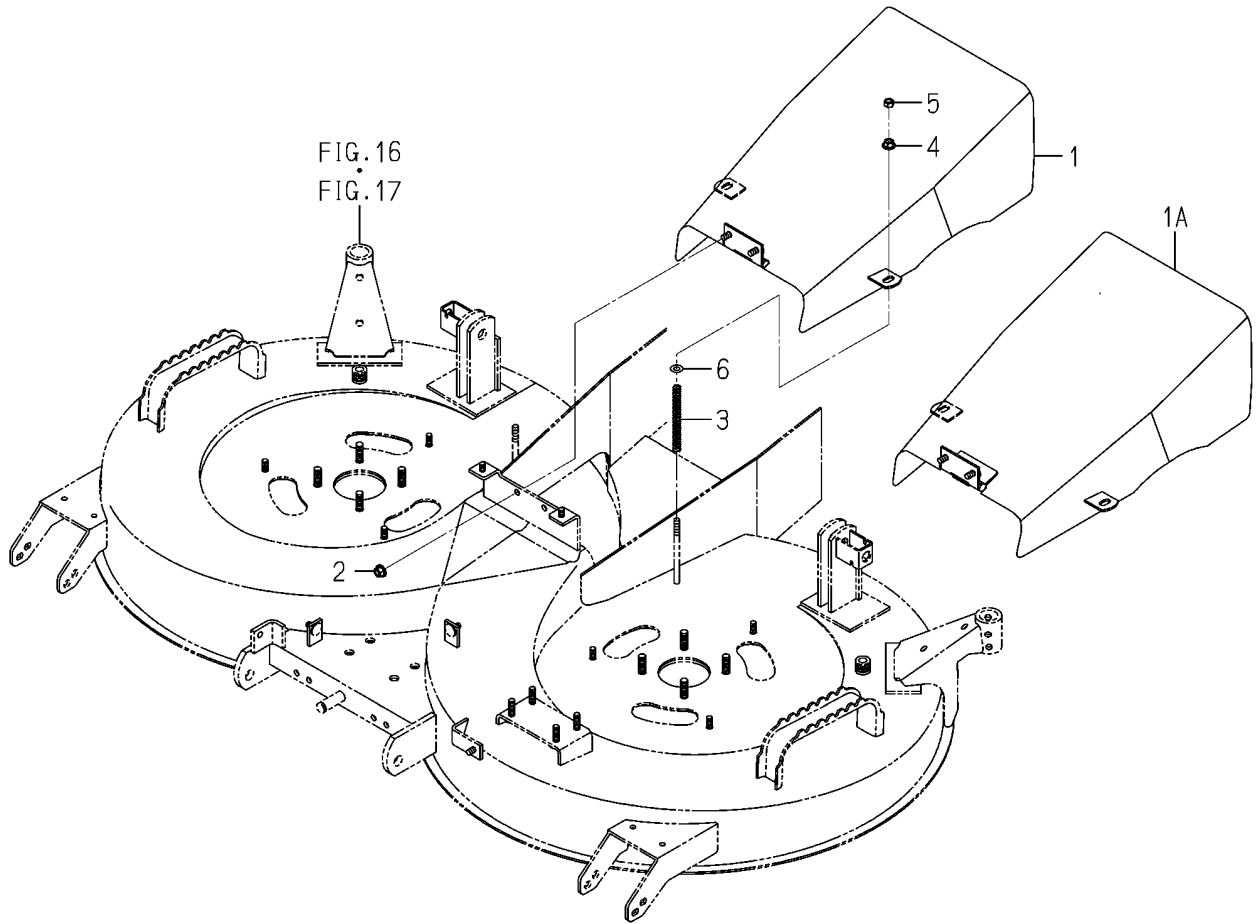

図番	部品コード	品名	仕様	型式				代替性	色番号	グループ	備考
				SCMA48 SXG22F	SCMA54 SXG22F						
1	8665-406-510-00	COVER/DISCHARGE/B			1 -500024				7F		
1A	8665-406-510-10	COVER/DISCHARGE/B			1 500025-				7F		
2	V363-260-008-00	NUT/WASHER/M8			2						
3	8663-406-001-00	SPRING/HC110			2						
4	V363-260-008-00	NUT/WASHER/M8			2						
5	V304-260-008-00	NUT/M8			2						
6	V411-260-008-00	WASHER, PL/M8			2						

FIG.020 COVER(BELT)SYSTEM(SCMA48)

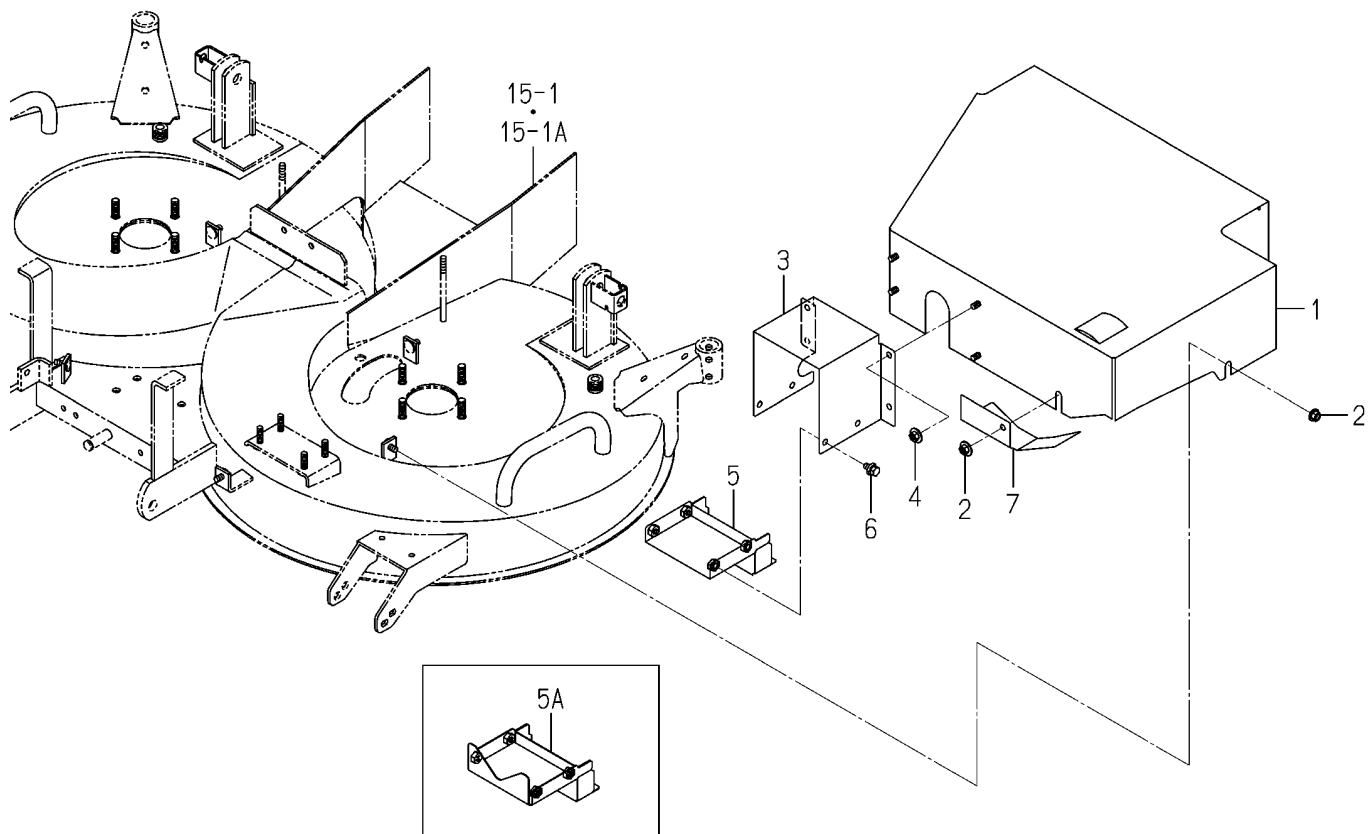

図番	部品コード	品名	仕様	型式					代替性	色番号	グループ	備考
				SCMA48 SXG22F	SCMA54 SXG22F							
1	8663-407-520-00	COVER/BELT/B	COMP	*	1						7F	
2	V363-260-008-00	NUT/WASHER/M8		*	5							
3	8663-407-052-00	COVER/JOINT		*	1						7F	
4	V363-260-008-00	NUT/WASHER/M8		*	4							
5	8663-407-540-00	COVER/YOKE	COMP	*	1 -300000						7F	
5A	8663-407-540-10	COVER/YOKE	COMP	*	1 300001-						7F	
6	V211-360-801-60	BOLT, SP/M8X16		*	4							
7	8663-407-053-00	COVER/UNDER/48		*	1 300001-							

FIG.021 COVER(BELT)SYSTEM (SCMA54)(NO.1-400725)

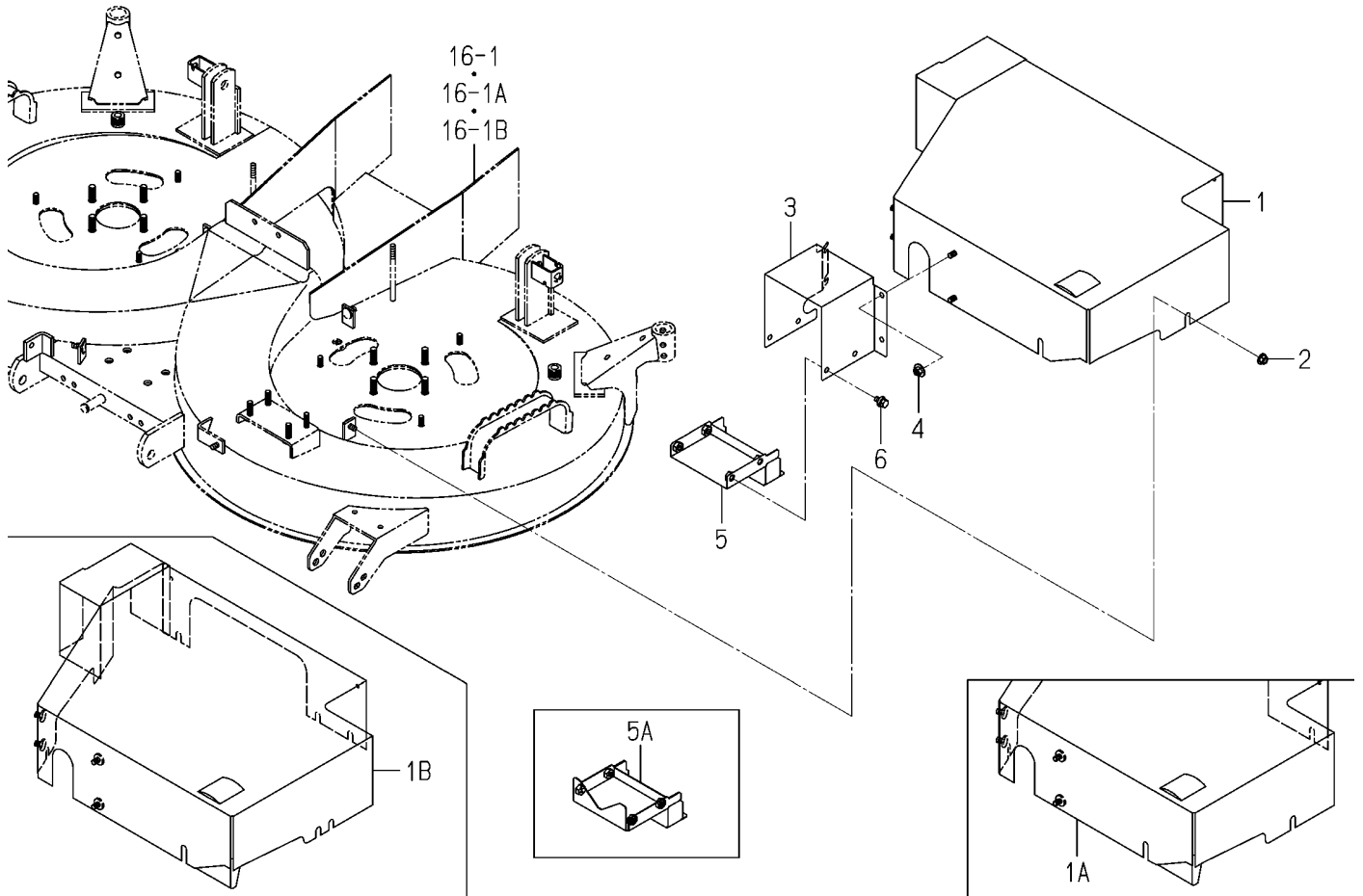

図番	部品コード	品名	仕様	型式				代替性	色番号	グループ	備考
				SCMA48 SXG22F	SCMA54 SXG22F						
1	8665-407-520-00	COVER/BELT/B	COMP		1 -300000				7F		
1A	8665-407-520-10	COVER/BELT/B	COMP		1 -400456				7F		
1B	8665-407-520-20	COVER/BELT/B	COMP		1 -400725				7F		
2	V363-260-008-00	NUT/WASHER/M8			5 -400725						
3	8665-407-051-00	COVER/JOINT			1 -400725			7F			
4	V363-260-008-00	NUT/WASHER/M8			4 -400725						
5	8663-407-540-00	COVER/YOKE	COMP		1 -300000			7F			
5A	8663-407-540-10	COVER/YOKE	COMP		1 -400725			7F			
6	V211-360-801-60	BOLT, SP/M8X16			4 -400725						

FIG.022 COVER SYSTEM(SCMA54)(NO.500001-)

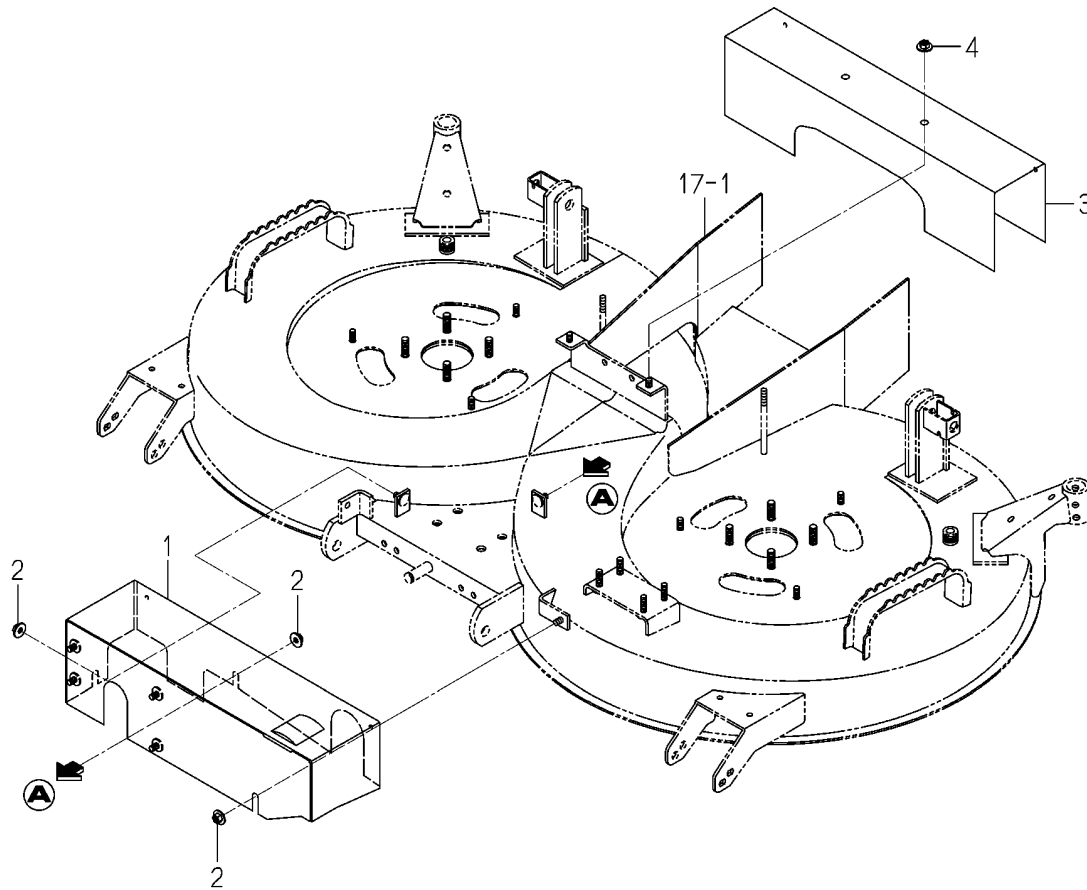

図番	部品コード	品名	仕様	型式					代替性	色番号	グループ	備考
				SCMA48 SXG22F	SCMA54 SXG22F							
1	8665-407-710-00	COVER/PULLEY COMP			1 500001-							
2	V363-260-008-00	NUT/WASHER/M8			3 500001-							
3	8665-407-071-00	COVER/SHAFT			1 500001-							
4	V363-260-008-00	NUT/WASHER/M8			2 500001-							

FIG.023 WHEEL(GAUGE)SYSTEM

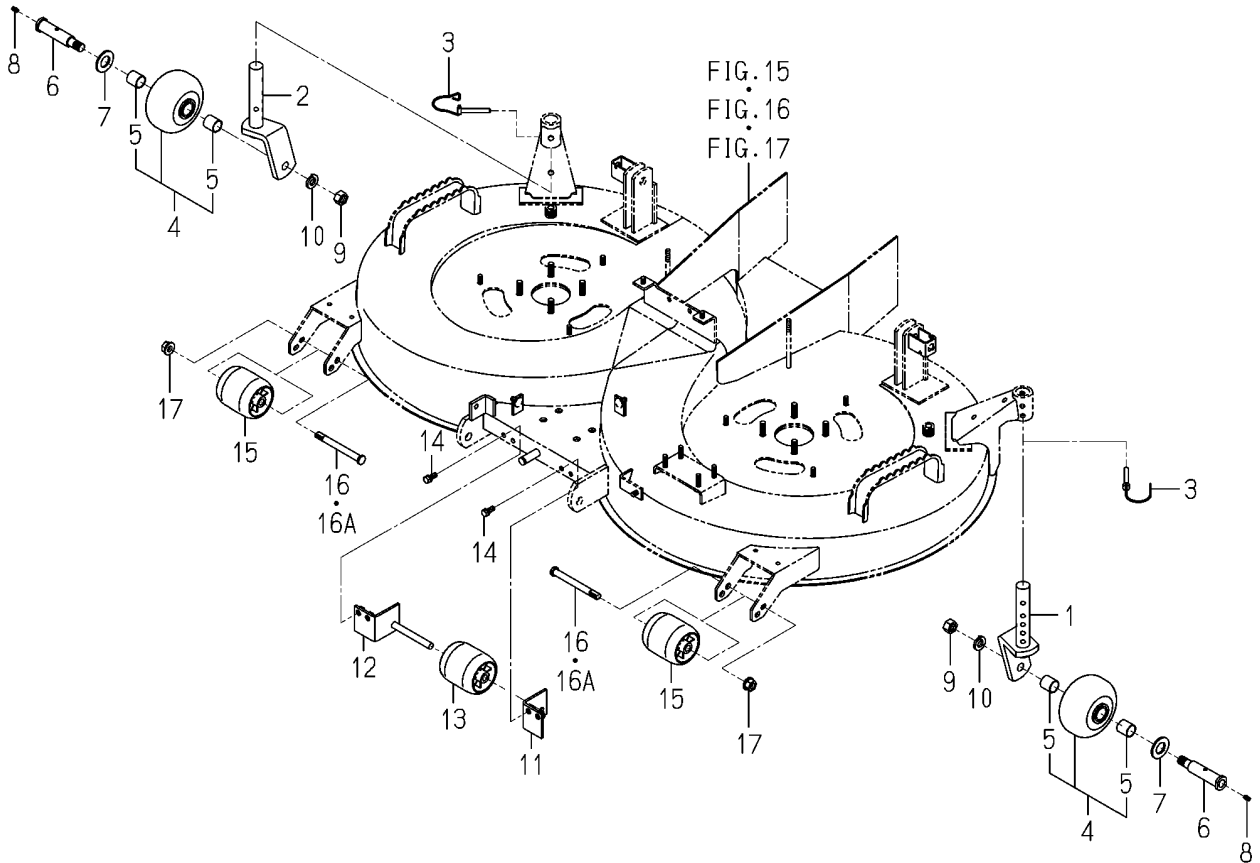

図番	部品コード	品名	仕様	型式				代替性	色番号	グループ	備考
				SCMA48 SXG22F	SCMA54 SXG22F						
1	8663-501-210-00	FORK/WHEEL/LH COMP	*	1	1						
2	8663-501-220-00	FORK/WHEEL/RH COMP	*	1	1						
3	8663-501-240-00	PIN/08X60 COMP	*	2	2						
4	8657-501-530-00	WHEEL/GAUGE ASSY	*	2	2						
5	8654-501-283-00	BUSH/22X25X25	*	4	4						
6	8663-501-001-10	PIN/22X106	*	2	2						
7	V411-260-022-00	WASHER, PL/M22	*	2	2						
8	V760-150-000-00	NIPPLE, GREASE	*	2	2						
9	V304-460-016-00	NUT/M16/7T	*	2	2						
10	V401-160-016-00	WASHER, SP/M16	*	2	2						
11	8663-501-510-00	STAY/GAUGE/LH COMP	*	1	1						
12	8663-501-520-00	STAY/GAUGE/RH COMP	*	1	1						
13	8595-501-001-20	WHEEL/GAUGE/FRONT	*	1	1						
14	V211-260-802-00	BOLT, S/M8X20	*	4	4						
15	8595-501-001-20	WHEEL/GAUGE/FRONT	*	2	2						
16	8595-505-051-30	PIN/12X117	*	2 -300799	2 -300240						
16A	8663-501-051-00	PIN/12X117	*	2 300800-	2 300241-						
17	V360-260-012-00	NUT/WASHER/M12	*	2	2						

FIG.024 LINK SYSTEM

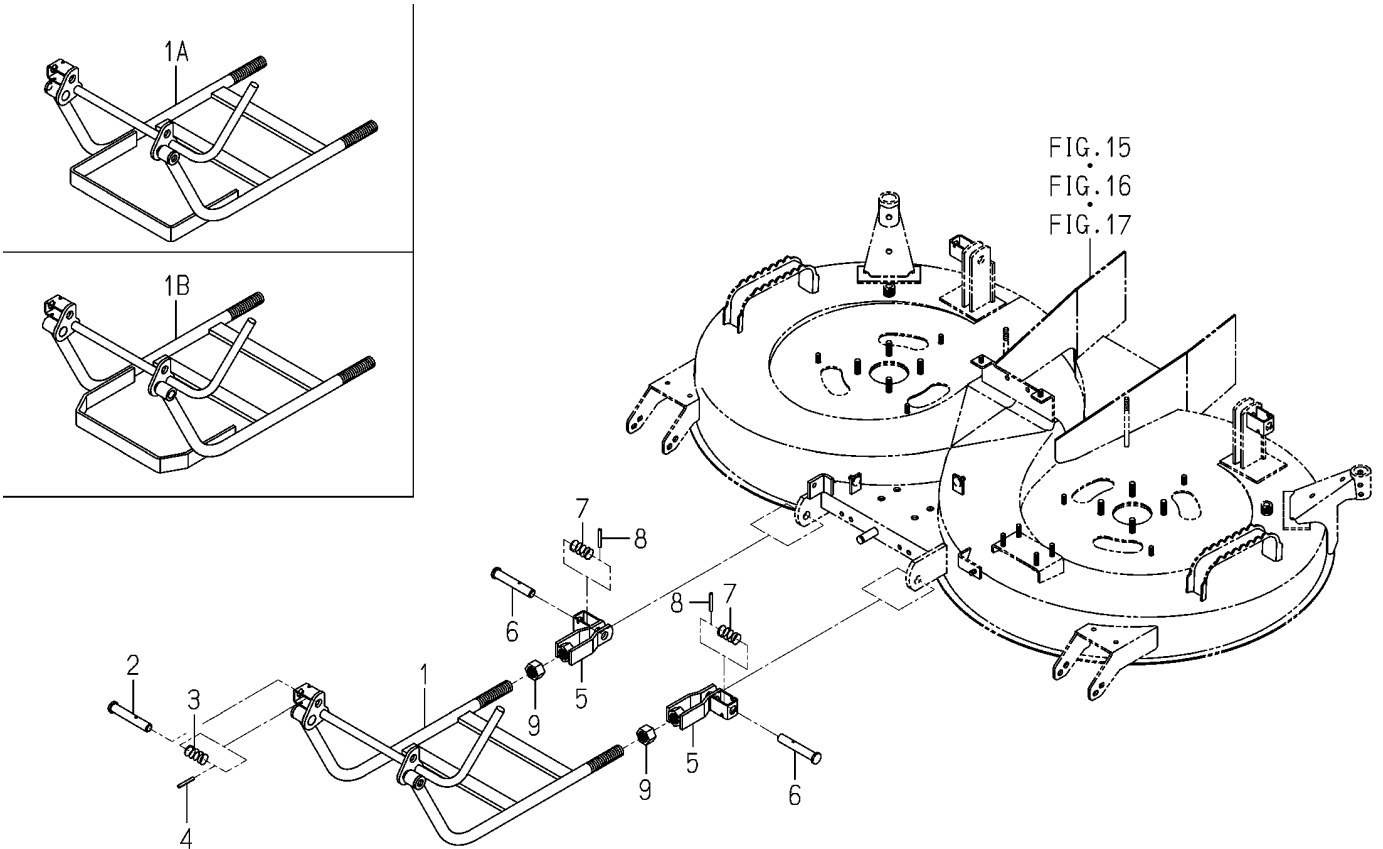

図番	部品コード	品名	仕様	型式		代替性	色番号	グループ	備考
				SCMA48 SXG22F	SCMA54 SXG22F				
1	8663-608-210-10	ARM/FRONT	COMP	* 1 -401287	1 -400353		7F		
1A	8663-608-210-20	ARM/FRONT	COMP	* 1 -401290	1 -500024		7F		
1B	8663-608-210-30	ARM/FRONT	COMP	* 1 401291-	1 500025-		7F		
2	8595-608-082-10	PIN/16X96		* 1	1				
3	1560-601-028-00	SPRING/HCO42		* 1	1				
4	V580-140-504-00	PIN, SPRING/5X40 W		* 1	1				
5	8657-608-720-00	FORK/M22	COMP	* 2	2				
6	8595-608-082-10	PIN/16X96		* 2	2				
7	1560-601-028-00	SPRING/HCO42		* 2	2				
8	V580-140-504-00	PIN, SPRING/5X40 W		* 2	2				
9	V334-460-022-00	NUT/M22		* 2	2				

FIG.025 LABEL(SCMA54)(NO.400347-)

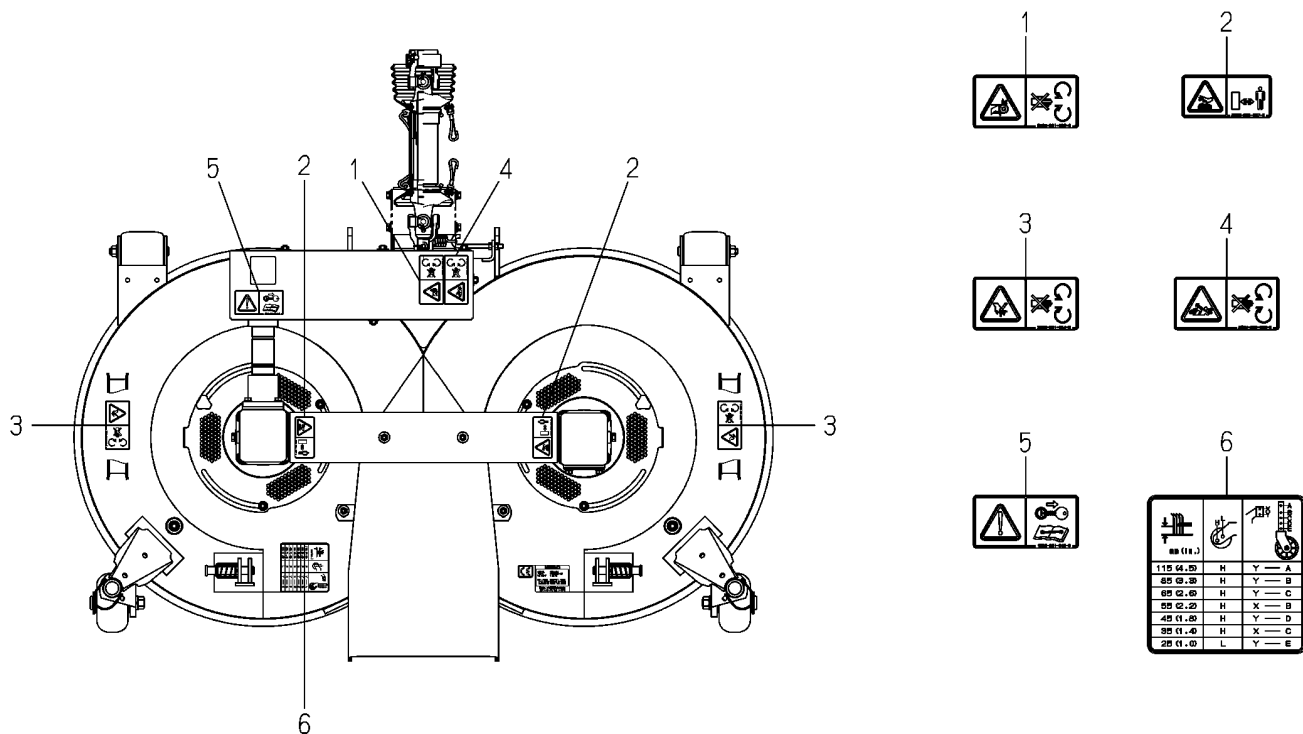

図番	部品コード	品名	仕様	型式				代替性	色番号	グループ	備考
				SCMA48 SXG22F	SCMA54 SXG22F						
1	8595-901-006-00	LABEL/WARNING/BELT			1 400347-						
2	8595-901-007-00	LABEL/WARNING/HOT			2 400347-						
3	2500-901-014-30	LABEL/DANGER			2 400347-						
4	8654-901-002-00	LABEL/PTO			1 400347-						
5	1593-901-015-00	LABEL/MAINTENANCE			1 400347-						
6	8674-901-001-00	LABEL/GAUGEWHEEL			1 400347-						

FIG.026 LABEL(SCMA54-NO.1-400346)

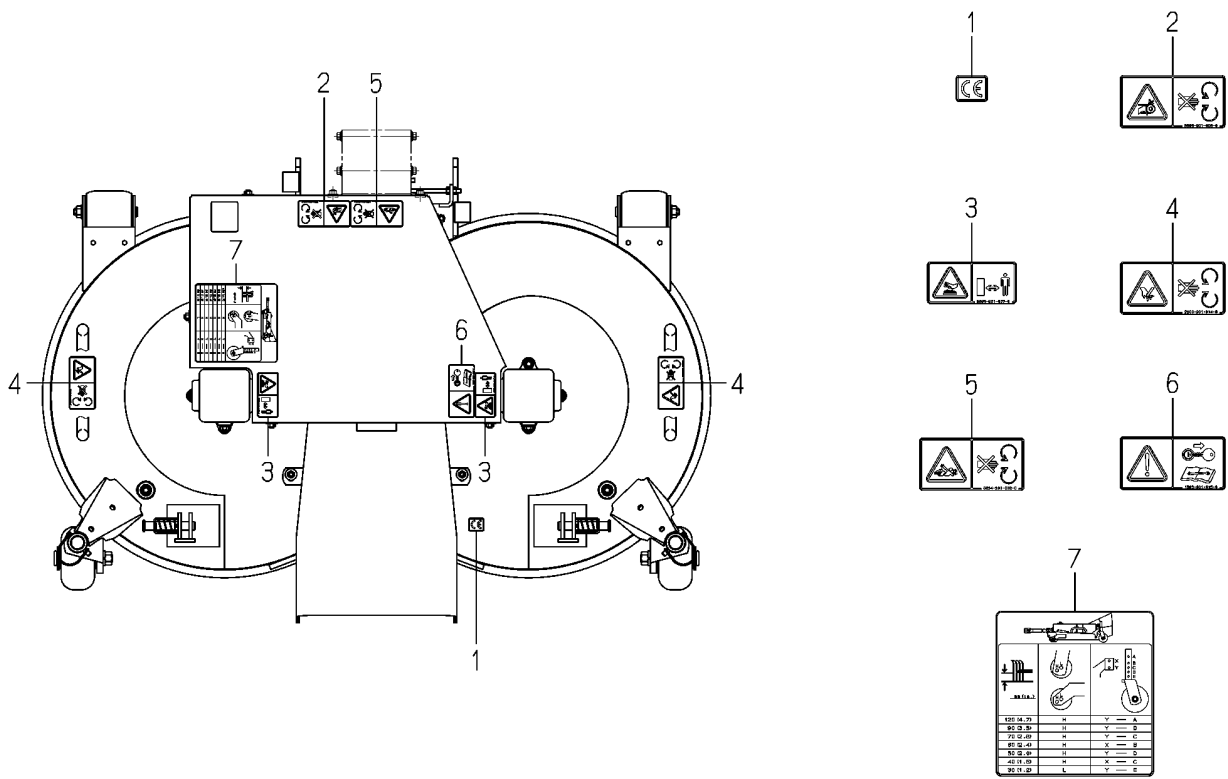

図番	部品コード	品名	仕様	型式				代替性	色番号	グループ	備考
				SCMA48 SXG22F	SCMA54 SXG22F						
1	2500-901-027-00	LABEL/CE	*	1	1 -400346						
2	8595-901-006-00	LABEL/WARNING/BELT	*	1	1 -400346						
3	8595-901-007-00	LABEL/WARNING/HOT	*	2	2 -400346						
4	2500-901-014-30	LABEL/DANGER	*	2	2 -400346						
5	8654-901-002-00	LABEL/PTO	*	1	1 -400346						
6	1593-901-015-00	LABEL/MAINTENANCE	*	1	1 -400346						
7	8663-901-001-00	LABEL/GAUGEWHEEL	*	1	1 -400346						

FIG.027 LABEL(CE)(SCMA54)(NO.400347-)

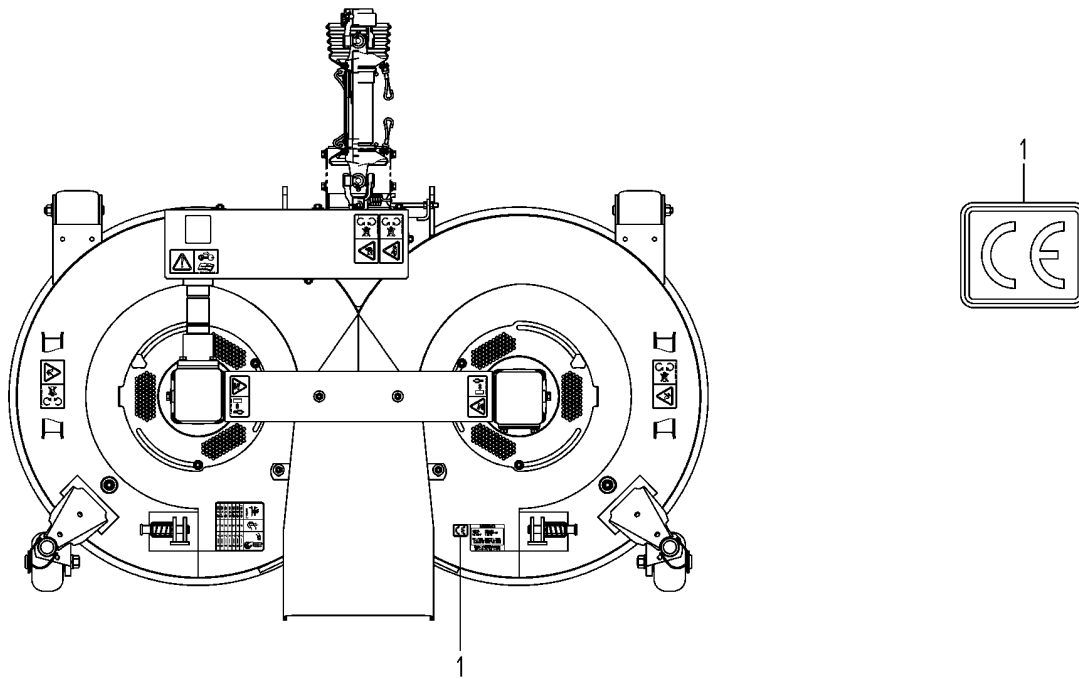

図番	部品コード	品名	仕様	型式					代替性	色番号	グループ	備考
				SCMA48 SXG22F	SCMA54 SXG22F							
1	2500-901-027-00	LABEL/CE			1 400347-							

FIG.028 GEAR(B/21-25-21),GEAR(BEVEL/25-21)SET (SCMA54)(NO.500001-) (1/2)

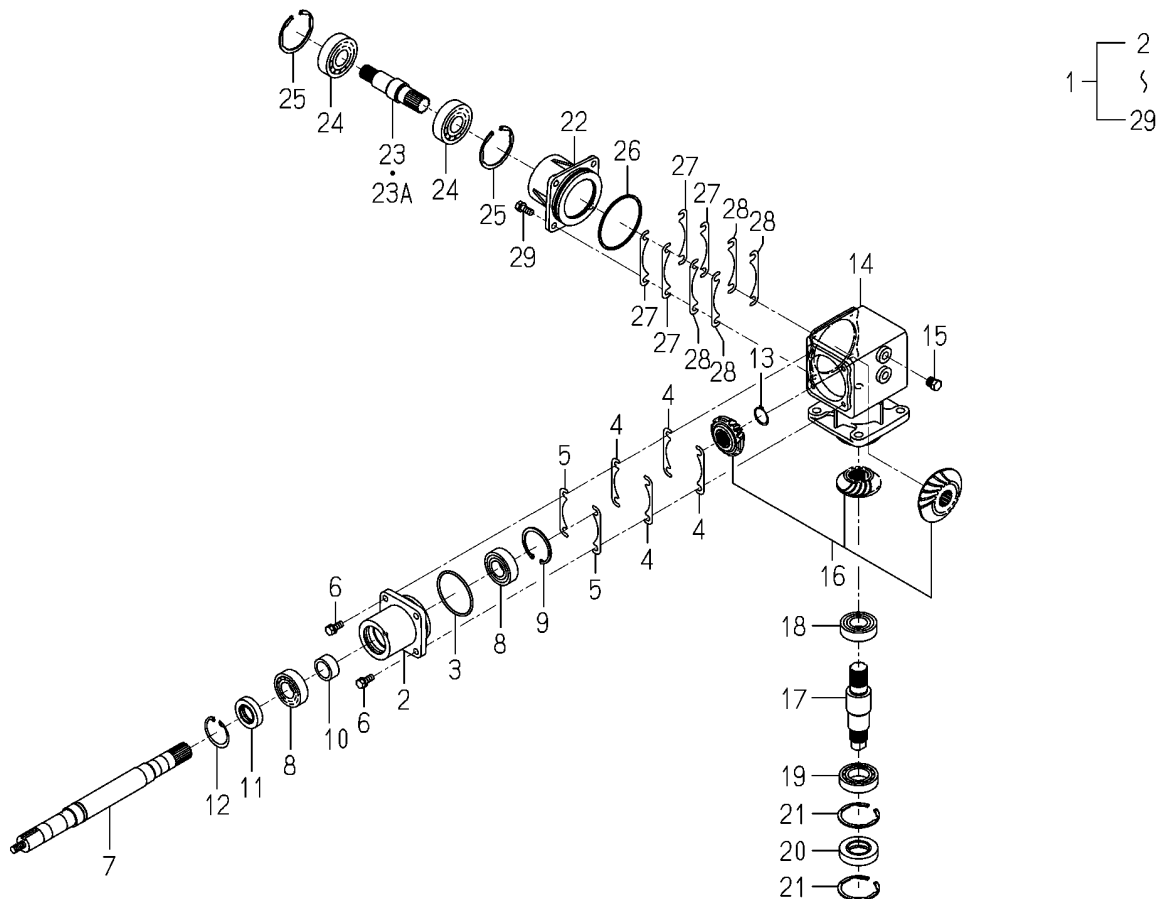

図番	部品コード	品名	仕様	型式				代替性	色番号	グループ	備考
				SCMA48 SXG22F	SCMA54 SXG22F						
1	8665-202-710-00	CASE/BEVEL/LH ASSY			1 500001-						
2	8674-202-001-20	METAL/CASE			1 500001-						
3	V721-103-106-50	O-RING/1A, G65			1 500001-						
4	8663-202-055-00	SHIM/O. 1			4 500001-						
5	8663-202-056-00	SHIM/O. 2			2 500001-						
6	V211-560-802-00	BOLT, S/M8X20/7T			4 500001-						
7	8665-202-071-00	SHAFT/LH/54			1 500001-						
8	1594-221-001-00	BEARING/BALL 6205SH2			2 500001-						
9	V705-140-052-00	RING, SNAP/52 C			1 500001-						
10	8674-202-003-00	COLLAR/25X34X15			1 500001-						
11	V744-128-451-10	SEAL, OIL/TC284511			1 500001-						
12	V705-140-045-00	RING, SNAP/45 C			1 500001-						
13	V704-140-025-00	RING, SNAP/25 C			1 500001-						
14	8674-202-004-00	CASE/BEVEL			1 500001-						
15	7955-201-026-00	PLUG, DRAIN (1/4)			2 500001-						
16	8674-202-210-00	GEAR/B/21-25-21 SET			1 500001-						
17	8674-202-007-00	SHAFT/BLADE			1 500001-						
18	1594-221-001-00	BEARING/BALL 6205SH2			1 500001-						
19	V600-110-600-60	BEARING, RB/6006			1 500001-						
20	V744-130-551-20	SEAL, OIL/TC305512			1 500001-						
21	V707-140-055-00	RING, SNAP/R55			2 500001-						
22	8667-201-002-02	METAL/INPUT			1 500001-			7F			
23	8674-202-009-00	SHAFT/CASE			1 500001-						
23A	8674-202-009-10	SHAFT/CASE			1 500001-						
24	1594-218-001-00	BEARING/BALL 6305SH2			2 500001-						
25	V707-140-062-00	RING, SNAP/R62			2 500001-						
26	V721-103-108-00	O-RING/1A, G80			1 500001-						
27	8595-201-021-00	SHIM/O. 1			4 500001-						
28	8595-201-022-00	SHIM/O. 2			4 500001-						
29	V211-560-802-00	BOLT, S/M8X20/7T			4 500001-						

FIG.028A GEAR(B/21-25-21),GEAR(BEVEL/25-21)SET (SCMA54)(NO.500001-) (2/2)

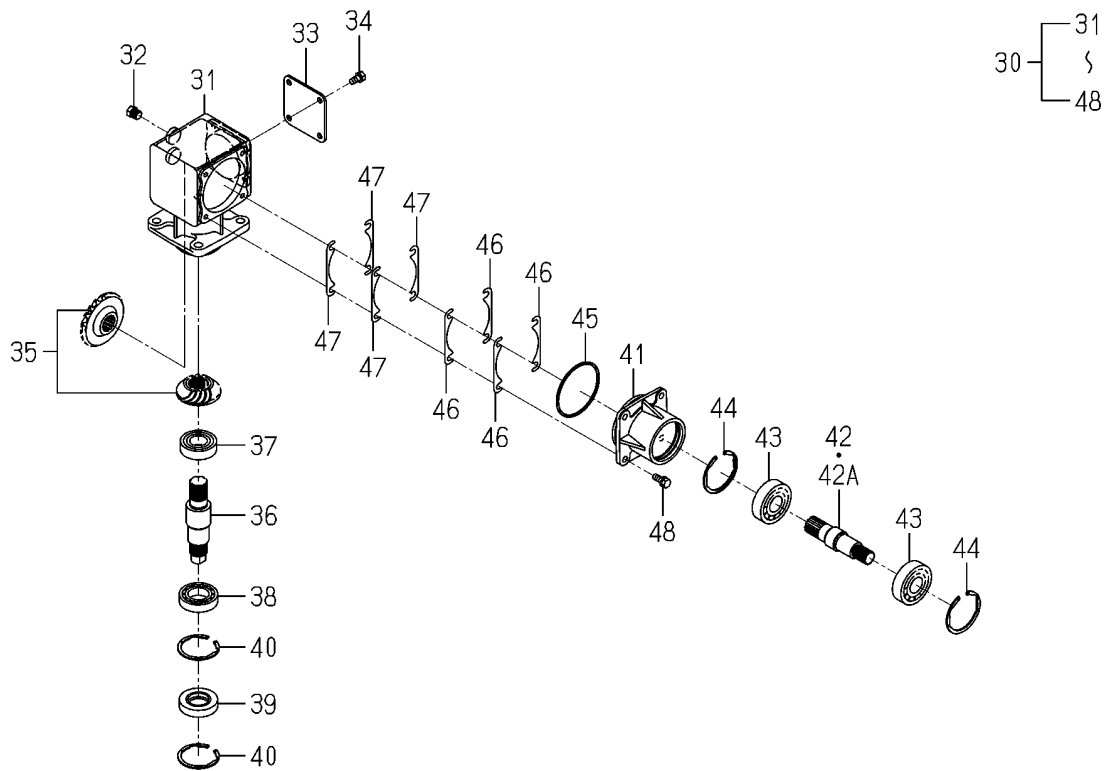

図番	部品コード	品名	仕様	型式				代替性	色番号	グループ	備考
				SCMA48 SXG22F	SCMA54 SXG22F						
30	8674-202-320-00	CASE/BEVEL/RH ASSY			1 500001-						
31	8674-202-004-00	CASE/BEVEL			1 500001-						
32	7955-201-026-00	PLUG, DRAIN (1/4)			2 500001-						
33	8674-202-006-00	COVER/CASE			1 500001-						
34	V211-260-801-60	BOLT, S/M8X16			4 500001-						
35	8674-202-220-00	GEAR/BEVEL/25-2 SET			1 500001-						
36	8674-202-007-00	SHAFT/BLADE			1 500001-						
37	1594-221-001-00	BEARING/BALL 6205SH2			1 500001-						
38	V600-110-600-60	BEARING, RB/6006			1 500001-						
39	V744-130-551-20	SEAL, OIL/TC305512			1 500001-						
40	V707-140-055-00	RING, SNAP/R55			2 500001-						
41	8667-201-002-02	METAL/INPUT			1 500001-			7F			
42	8674-202-009-00	SHAFT/CASE			1 -500482						
42A	8674-202-009-10	SHAFT/CASE			1 500483-						
43	1594-218-001-00	BEARING/BALL 6305SH2			2 500001-						
44	V707-140-062-00	RING, SNAP/R62			2 500001-						
45	V721-103-108-00	O-RING/1A, G80			1 500001-						
46	8595-201-021-00	SHIM/O. 1			4 500001-						
47	8595-201-022-00	SHIM/O. 2			4 500001-						
48	V211-560-802-00	BOLT, S/M8X20/7T			4 500001-						

FIG.029 GEAR(B/21-25-21),GEAR(BEVEL/25-21)SET (SCMA54-NO.1-400725) (1/2)

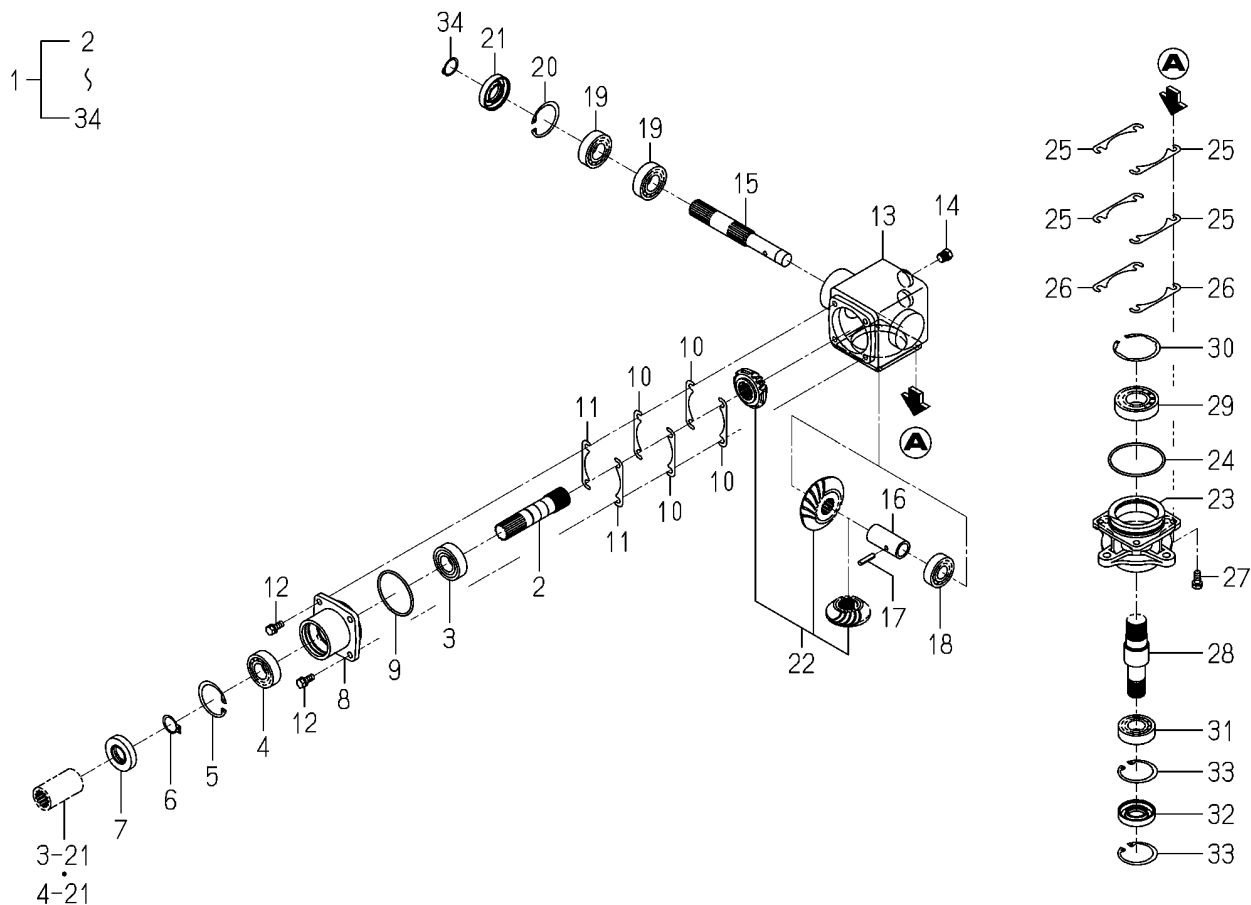

図番	部品コード	品名	仕様	型式				代替性	色番号	グループ	備考
				SCMA48 SXG22F	SCMA54 SXG22F						
1	8663-202-560-10	CASE/BEVEL/LH ASSY	R	1	1 -400725						
2	8663-202-051-00	SHAFT/LH/REAR	R	1	1 -400725						
3	1594-221-001-00	BEARING/BALL 6205SH2	R	1	1 -400725						
4	V600-110-620-50	BEARING, RB/6205	R	1	1 -400725						
5	V705-140-052-00	RING, SNAP/52 C	R	1	1 -400725						
6	V704-140-025-00	RING, SNAP/25 C	R	1	1 -400725						
7	V744-125-521-00	SEAL, OIL/TC255210	R	1	1 -400725						
8	8663-202-052-10	METAL/BEVELCASE	R	1	1 -400725						
9	V721-103-106-50	O-RING/1A, G65	R	1	1 -400725						
10	8663-202-055-00	SHIM/0.1	R	4	4 -400725						
11	8663-202-056-00	SHIM/0.2	R	2	2 -400725						
12	V211-260-802-00	BOLT, S/M8X20	R	4	4 -400725						
13	8663-202-057-10	CASE/BEVEL/LH	R	1	1 -400725						
14	7955-201-026-00	PLUG, DRAIN (1/4)	R	2	2 -400725						
15	8663-202-058-10	SHAFT/CASE	R	1	1 -400725						
16	8663-202-059-00	HUB/SPACER	R	1	1 -400725						
17	V580-140-602-80	PIN, SPRING/6X28 W	R	1	1 -400725						
18	V600-110-620-40	BEARING, RB/6204	R	1	1 -400725						
19	V600-110-620-50	BEARING, RB/6205	R	2	2 -400725						
20	V705-140-052-00	RING, SNAP/52 C	R	1	1 -400725						
21	V744-125-521-00	SEAL, OIL/TC255210	R	1	1 -400725						
22	8663-202-610-00	GEAR/B/21-25-21 SET	R	1	1 -400725						
23	8663-301-051-30	METAL/BLADE/B	R	1	1 -400725						
24	V721-103-107-50	O-RING/1A, G75	R	1	1 -400725						
25	8595-201-021-00	SHIM/0.1	R	4	4 -400725						
26	8595-201-022-00	SHIM/0.2	R	2	2 -400725						
27	V211-260-802-00	BOLT, S/M8X20	R	4	4 -400725						
28	8663-301-052-10	SHAFT/BLADE/B	R	1	1 -400725						
29	V600-110-620-60	BEARING, RB/6206	R	1	1 -400725						
30	V707-140-062-00	RING, SNAP/R62	R	1	1 -400725						

FIG.029A GEAR(B/21-25-21),GEAR(BEVEL/25-21)SET (SCMA54-NO.1-400725) (2/2)

31~34-PLEASE SEE 1/2 PAGE

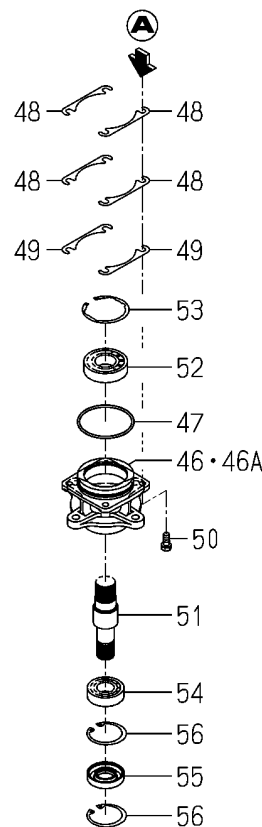
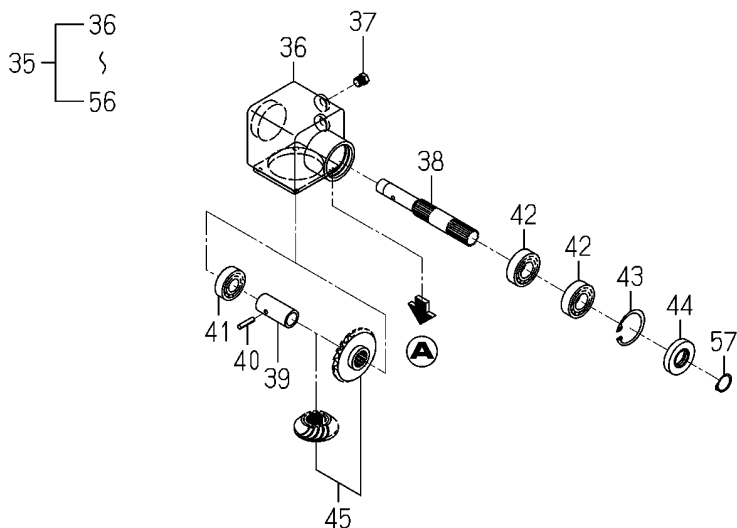

図番	部品コード	品名	仕様	型式				代替性	色番号	グループ	備考
				SCMA48 SXG22F	SCMA54 SXG22F						
31	V600-110-620-50	BEARING, RB/6205	R	1	1 -400725						
32	V744-125-521-00	SEAL, OIL/TC255210	R	1	1 -400725						
33	V705-140-052-00	RING, SNAP/52 C	R	2	2 -400725						
34	1725-218-006-00	RING/SNAP/CS25	R	1	1 -400725						
35	8663-202-570-10	CASE/BEVEL/RH ASSY	R	1	1 -400725						
36	8663-202-062-10	CASE/BEVEL/RH	R	1	1 -400725			7F			
37	7955-201-026-00	PLUG, DRAIN (1/4)	R	2	2 -400725						
38	8663-202-058-10	SHAFT/CASE	R	1	1 -400725						
39	8663-202-059-00	HUB/SPACER	R	1	1 -400725						
40	V580-140-602-80	PIN, SPRING/6X28 W	R	1	1 -400725						
41	V600-110-620-40	BEARING, RB/6204	R	1	1 -400725						
42	V600-110-620-50	BEARING, RB/6205	R	2	2 -400725						
43	V705-140-052-00	RING, SNAP/52 C	R	1	1 -400725						
44	V744-125-521-00	SEAL, OIL/TC255210	R	1	1 -400725						
45	8663-202-620-00	GEAR/BEVEL/25-2 SET	R	1	1 -400725						
46	8663-301-051-20	METAL/BLADE/B	R	1	1 -400725						
46A	8663-301-051-30	METAL/BLADE/B	R	1	1 -400725						
47	V721-103-107-50	O-RING/1A, G75	R	1	1 -400725						
48	8595-201-021-00	SHIM/O. 1	R	4	4 -400725						
49	8595-201-022-00	SHIM/O. 2	R	2	2 -400725						
50	V211-260-802-00	BOLT, S/M8X20	R	4	4 -400725						
51	8663-301-052-10	SHAFT/BLADE/B	R	1	1 -400725						
52	V600-110-620-60	BEARING, RB/6206	R	1	1 -400725						
53	V707-140-062-00	RING, SNAP/R62	R	1	1 -400725						
54	V600-110-620-50	BEARING, RB/6205	R	1	1 -400725						
55	V744-125-521-00	SEAL, OIL/TC255210	R	1	1 -400725						
56	V705-140-052-00	RING, SNAP/52 C	R	2	2 -400725						
57	1725-218-006-00	RING/SNAP/CS25	R	1	1 -400725						

FIG.030 COMPONENT PARTS FOR 8663-101-510-00 ON Fig.1

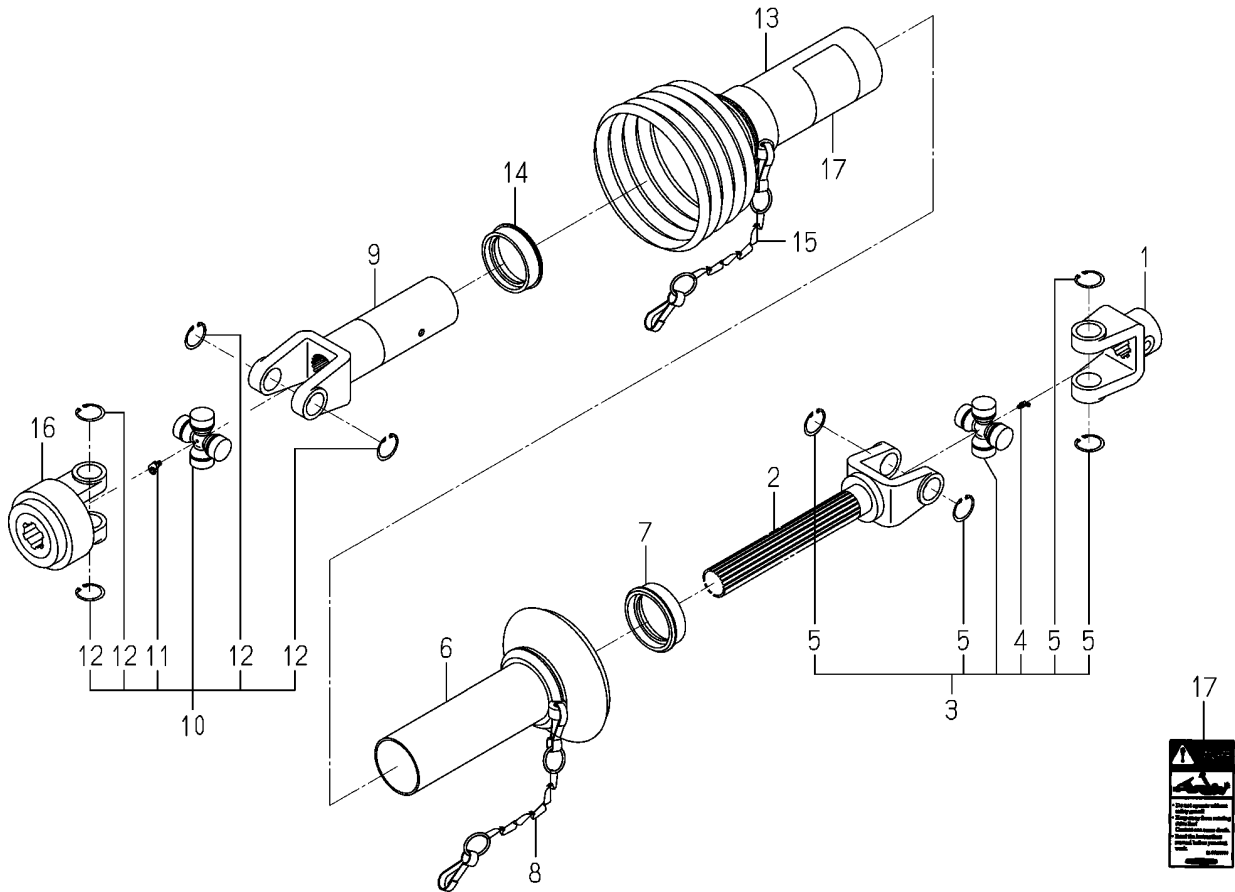

図番	部品コード	品名	仕様	型式				代替性	色番号	グループ	備考
				SCMA48 SXG22F	SCMA54 SXG22F						
1	8654-101-221-00	FITTINGYOKE	*	1	1						
2	8663-101-211-00	SHAFTYOKE	*	1	1						
3	8654-101-230-00	JOURNALCROSSE ASSY	*	1	1						
4	8654-101-232-00	GREASENIPPLE	*	1	1						
5	8654-101-233-00	SURCLIP/HOLE	*	4	4						
6	8663-101-521-00	SAFETYGUARD/IN	*	1	1						
7	7821-102-008-00	RING/SLIDE	*	1	1						
8	7821-102-220-00	CHAIN ASSY	*	1	1						
9	8595-101-731-00	SLEEVEYOKE	*	1	1						
10	8654-101-230-00	JOURNALCROSSE ASSY	*	1	1						
11	8654-101-232-00	GREASENIPPLE	*	1	1						
12	8654-101-233-00	SURCLIP/HOLE	*	4	4						
13	8663-101-531-00	SAFETYGUARD/OUT	*	1	1						
14	7821-102-008-00	RING/SLIDE	*	1	1						
15	7821-102-220-00	CHAIN ASSY	*	1	1						
16	8657-101-501-00	AS YOKE ASSY	*	1	1						
17	8658-101-674-00	LABEL/DANGER/JOINT/G	*	1	1						