

Directions for use of Parts Catalogue

1. Applicable model of machines

All component and option parts used for SW621 Mower are listed in this parts catalogue.

Description of type of machines and particulars

Type of Machines	Section	Engines	
		FC180V AA00 BA00 CA00	FC180V AB00 BB00
SW621	E01		○
	BE01	○	

Note: When you place an order for spare parts, please check and specify the Engine Model of your machine.

2. Explanation for head paragraph

K500-101

KEY Ref.	PART CODE Pièces No.	DESCRIPTION	Désignation	QTY Quant.	TYPE OF MODEL			Modél FC150V GB03	I T C	C O L	G R P	REMARKS Remarques
					FC150V AB03	FC150V FB03						
1	5130-702-077-XX	GUIDE	Guide	1	*	*	*					130702077
2	5510-012-214-XX	TANK-COMP-FUEL	Reservoir	1	*	*	*					510012214
3	5510-482-069-XX	CAP-ASSY-TANK	Ens. bouchon	1	*	*	*					510482069
4	5110-092-831-XX	GASKET	Joint	1	*	*	*					110092831
		NET BREATHER	Element	1	*							318292665600
			Element	1		*	*					491092054
				1	*	*	*					490192091
				1	*	*	*					490192094
					*	*	*					1316823

- ① KEY shows the location of parts diagramed in the illustration.
- ② Parts numbers begin with `V` and `W` are standard parts of the market.
- ③ `LH` and `RH` on the parts name are described against the moving direction of the machine or are described on the condition how to install parts on the machines.
- ④ QTY shows the number of parts to be used for one unit of machine.
 - `M` is indicated for parts supplied by a meter long.
 - `ℓ` is indicated for parts supplied by liter.
 - `AR` is indicated for parts need to be adjusted or regulated.

- ⑤ The following symbol classifies parts to be used for machines.
- ` * ` means standard parts.
 - ` T ` shows that the parts can be installed as optional parts.
 - ` R ` shows that the parts can be used as applicable parts to replace originally equipped parts.
- ⑥ Serial number : upper row shows the serial number for the first product and lower row for the last product.
- Example : Serial no. 1 through to serial no. 1999.
- ⑦ ITC : Interchangeability
- ` 1 ` ...OLD ← NEW
New parts can be used in place of the old parts.
 - ` 2 ` ...OLD → NEW
Old parts can be used in place of the new parts.
 - ` 3 ` ...OLD NEW
Old parts and new parts can not be replaced each other.
- ⑧ COL : Color code
- Color is signified with color code number for colored parts.
Please see the color list shown in the next page.
- ⑨ GRP : Parts shown in this column can be replaced by SET parts.
- Exsample : Parts marked Ⓐ can be replaced by parts marked Ⓑ, and Ⓓ for Ⓒ, so the rest follow in the same alphabetical order.
- ⑩ Remarks
- * Other maker's part code number is shown in this column.
 - * When Fig. No. is shown in the Remark column of SET parts or ASSY parts, each of their component parts are listed in said Fig. No.

3. Color :

The following colors are used for color parts.

COLOR CODE	COLOR	SPRAY TYPE CODE NUMBER	PAINTS 4K DRUM	PAINTS 16K DRUM
7 F	MIRROR BLACK	1300-954-001-10	1300-954-003-00	1300-954-004-00
8 E	SILVER MIST	1300-968-001-10	1300-968-003-00	1300-968-004-00

NOTE : Color code is signified only for the parts assigned by the maker as color parts.

4. Serial Numbers:

- 1) For engines serial number is stamped on CRANKCASE – COMP.

Please see FC180VAA00,BA00,CA00 Fig.No.1-14, 33, FC180VAB00,BB00 Fig.No.1-14

- 2) For chassies serial number is shown on the LABEL.

Please see



5. Parts Order

- 1) Parts numbers listed in the parts catalogue are all registered in "ISEKI on-line computer".
- 2) When you order parts, please make sure of correct numbers.
- 3) When substitute parts is available, the part number ordered will be automatically turned to a new part number.
- 4) Please be sure to use "ISEKI GENUINE PARTS".

Any other similar parts other than ISEKI parts when used may cause a trouble that makes us unable to repair or guarantee the warrant.

MODE D'EMPLOI DE CE CATALOGUE

1. Machine concernée

Toutes les pièces et composants utilisés pour la tondeuse SW519 sont repris dans ce manuel.

Explication du modèle et particularités de la machine

Machine	Modèle	Deutsch	English	Nederlands	Français	Moteur
---------	--------	---------	---------	------------	----------	--------

2. Explication du tableau principal

- 1) Réf. n° : C'est un numéro de référence pour trouver les pièces dans les plans.
- 2) Pièces n° : Chaque pièce possède son propre numéro de code à 12 chiffres avec lequel elle peut être contrôlée par ordinateur. Les pièces comportant un "V" ou un "W" dans leur numéro de code en tête sont procurable sur le marché.
- 3) "Gauche" et "Droite" dans la désignation de pièce se repère selon la direction de marche avant de la machine ou explique comment monter la pièce sur la machine.
- 4) Quant. : Cette colonne spécifie les quantités d'une pièce requise pour chaque section donnée.

"M" est utilisé pour des pièces fournies au mètre.
 "l" est utilisé pour des pièces fournies au litre.
 "AR" signifie "suivant les besoins".
- 5) Les symboles suivants classifient les pièces utilisées sur la machine.

"*" indique des pièces standards.
 "T" indique des pièces pouvant être utilisées en option.
 "R" indique des pièces pouvant remplacer des pièces montées d'origine.
- 6) Numéro de série : la ligne supérieure indique le numéro série de la première machine, la ligne inférieure le numéro de série de la dernière machine montée avec la pièce concernée.
 Exemple : du n° de série 1 jusqu'au n° 1999.

7) ITC : Interchangeabilité

"1" : indique que la nouvelle pièce (modifiée) peut remplacer l'ancienne.

"2" : indique qu'une ancienne pièce peut remplacer la nouvelle pièce.

"3" : indique que l'ancienne et la nouvelle pièce ne sont pas interchangeable.

8) Col : Code couleur

Indique le numéro de code couleur pour les pièces peintes. Veuillez vous référer à la liste sur la page suivante.

9) GRP :

Indique que la pièce peut être remplacée par un kit de pièces.

Ex. : les pièces marquées par un B remplacent des pièces marquées d'un A, D remplace C, etc....

10) Remarques :

* N° des pièces utilisées par d'autres fabricants.

* Si le numéro de figure (fig. n°) suit des pièces reprises dans un kit ou dans un ensemble de pièces, les vues éclatées de ces pièces sont reprises sous la fig. mentionnée.

3. Peinture

Les peintures suivantes sont utilisées :

Code couleur	Peinture	N° de code flacon	Peinture spray 4 kg	Peinture 16 kg
4 G	Crystal blue	1300-957-001-10	1300-957-003-00	1300-957-004-00
5 I	Sunset gray	1300-959-001-10	1300-959-003-00	1300-959-004-00
6 G	Summer white	1300-958-001-10	1300-958-003-00	1300-958-004-00
7 F	Mirror black	1300-954-001-10	1300-954-003-00	1300-954-004-00

Note : ne s'applique que si la pièce est indiquée comme étant peinte par le fabricant.

4. Numéro de série

- 1) Le numéro moteur est estampé sur le bloc moteur.
Réf. fig. n° 5-1.
- 2) Le numéro de châssis est indiqué sur l'étiquette.
Réf.

5. Commande de pièces

- 1) Les numéros des pièces indiqués dans le catalogue de pièces sont repris dans "l'ordinateur en ligne" d'Iseki.
- 2) Veuillez vous assurer que les numéros des pièces commandées sont exacts.
- 3) Si une pièce a été substituée, le numéro de pièce est automatiquement remplacé par le nouveau numéro.
- 4) Utilisez des pièces d'origine Iseki. Toutes autres pièces utilisées semblables mais différentes des pièces Iseki peuvent causer une anomalie que nous ne pourrions plus réparer ou garantir.

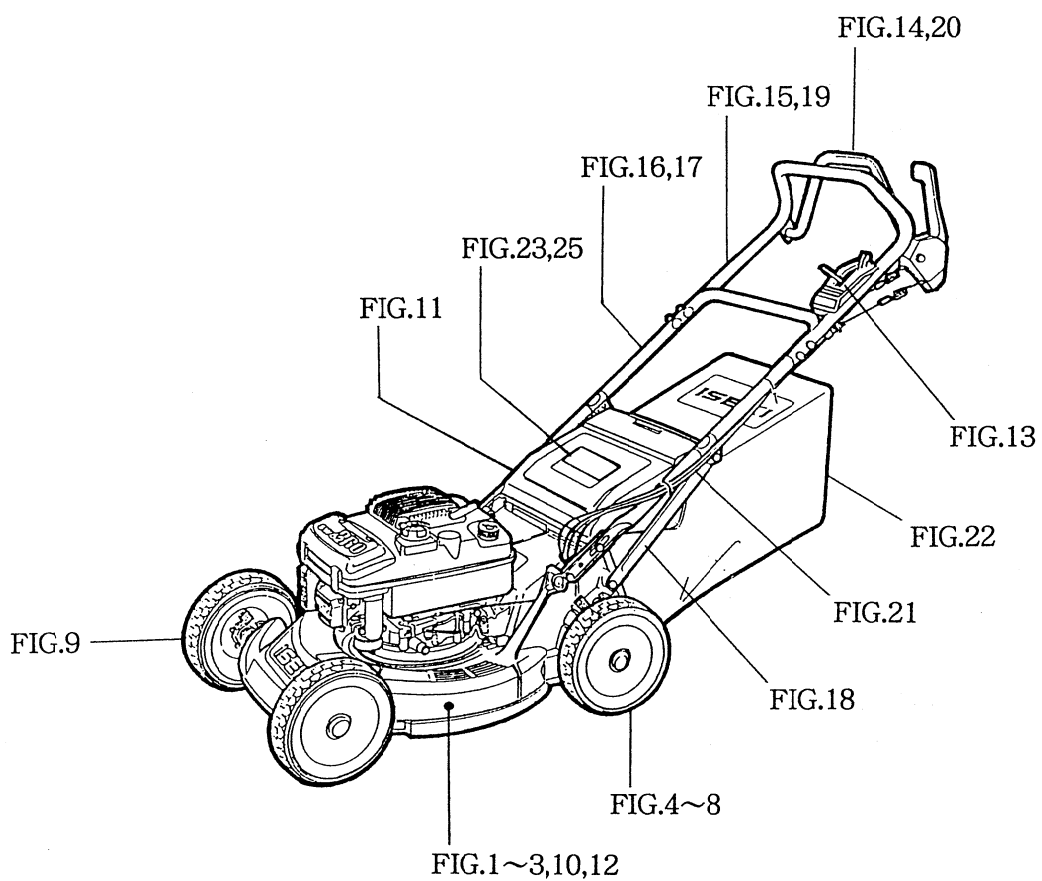

CONTENTS

ENGINE (FC180V – AA00,BA00,CA00)

Moteur

CYLINDER/CRANKCASE	Fig. 1
Cylindre/Carter	
PISTON/CRANKSHAFT	Fig. 2
Piston/Vilebrequin	
VALVE/CRANKSHAFT	Fig. 3
Soupape/Arbre a cames	
LUBRICATION – EQUIPMENT	Fig. 4
Lubrification	
COOLING – EQUIPMENT	Fig. 5
Refroidissement	
ELECTRIC – EQUIPMENT	Fig. 6
Électricité	
CONTROL – EQUIPMENT	Fig. 7
Commandes	
CARBURETOR	Fig. 8
Carburateur	
AIR – FILTER/MUFFLER	Fig. 9
Filtre à air/Echappement	
FUEL – TANK/FUEL – VALVE	Fig. 10
Reservoir/Robinet à acrburant	
STARTER	Fig. 11
Démarrreur	
LABEL	Fig. 12
Étiquette	
ACCESSORY	Fig. 13
Accessoire	

CONTENTS

ENGINE (FC180V – AB00,BB00)

Moteur

CYLINDER/CRANKCASE	Fig. 1
Cylindre/Carter	
PISTON/CRANKSHAFT	Fig. 2
Piston/Vilebrequin	
VALVE/CRANKSHAFT	Fig. 3
Soupape/Arbre à cames	
LUBRICATION – EQUIPMENT	Fig. 4
Lubrification	
COOLING – EQUIPMENT	Fig. 5
Refroidissement	
ELECTRIC – EQUIPMENT	Fig. 6
Électricité	
CONTROL – EQUIPMENT	Fig. 7
Commandes	
CARBURETOR	Fig. 8
Carburateur	
AIR – FILTER/MUFFLER	Fig. 9
Filtre à air/Echappement	
FUEL – TANK/FUEL – VALVE	Fig. 10
Resservoir/Robinet à carburant	
STARTER	Fig. 11
Démarreur	
BRAKE/COVER	Fig. 12
Frein de couvercle	
LABEL	Fig. 13
Étiquette	
ACCESSORY	Fig. 14
Accessoire	

CONTENTS

CHASSIS

ENGINE/BRAKE SYSTEM	Fig. 1
Système de freinage	
BLADE SYSTEM (EXCEPT B TYPE)	Fig. 2
Lame (excepté modèle B)	
BLADE SYSTEM (B TYPE)	Fig. 3
Lame (modèle B)	
RACHET SYSTEM	Fig. 4
Cliquet	
JOINT SYSTEM	Fig. 5
Cardan	
CASE SYSTEM	Fig. 6
Boitier	
GEAR SYSTEM	Fig. 7
Pignonnerie	
WHEEL/REAR SYSTEM	Fig. 8
Roue arrière	
WHEEL/FRONT SYSTEM	Fig. 9
Roue avant	
DECK FAN SYSTEM	Fig. 10
Carter de coupe	
COVER/DISCHARGE SYSTEM	Fig. 11
Déflecteur	
DECK SYSTEM	Fig. 12
Carter de coupe	
CONTROL LEVER SYSTEM	Fig. 13
Lever de contrôle	
LEVER SYSTEM (EXCEPT B TYPE)	Fig. 14
Lever (excepté modèle B)	
HANDLE SYSTEM (B TYPE)	Fig. 15
Mancheron (modèle B)	
HANDLE SYSTEM (B TYPE)	Fig. 16
Mancheron (modèle B)	
HANDLE SYSTEM (EXCEPT B TYPE)	Fig. 17
Mancheron (excepté modèle B)	

STAY/BAR/HANDLE SYSTEM.....	Fig. 18
Support	
HANDLE (B/E) SYSTEM (EXCEPT B TYPE)	Fig. 19
Mancheron (B/E) (excepté modèle B)	
LEVER SYSTEM (B TYPE).....	Fig. 20
Levier (modèle B)	
CABLE/BRAKE SYSTEM.....	Fig. 21
Câble de Frein	
COLLECTOR SYSTEM.....	Fig. 22
Collecteur	
MARK • LABEL SYSTEM.....	Fig. 23
Etiquettes	
SPECIAL TOOLS SYSTEM.....	Fig. 24
Outils	
ORNAMENT SYSTEM.....	Fig. 25
Enjoliveur	
TOOLS, MANUAL SYSTEM.....	Fig. 26
Outils/manuel	

ENGINE

FC180V – AA00,BA00,CA00

FIG. 1 CYLINDER/CRANKCASE
Cylindre/Carter

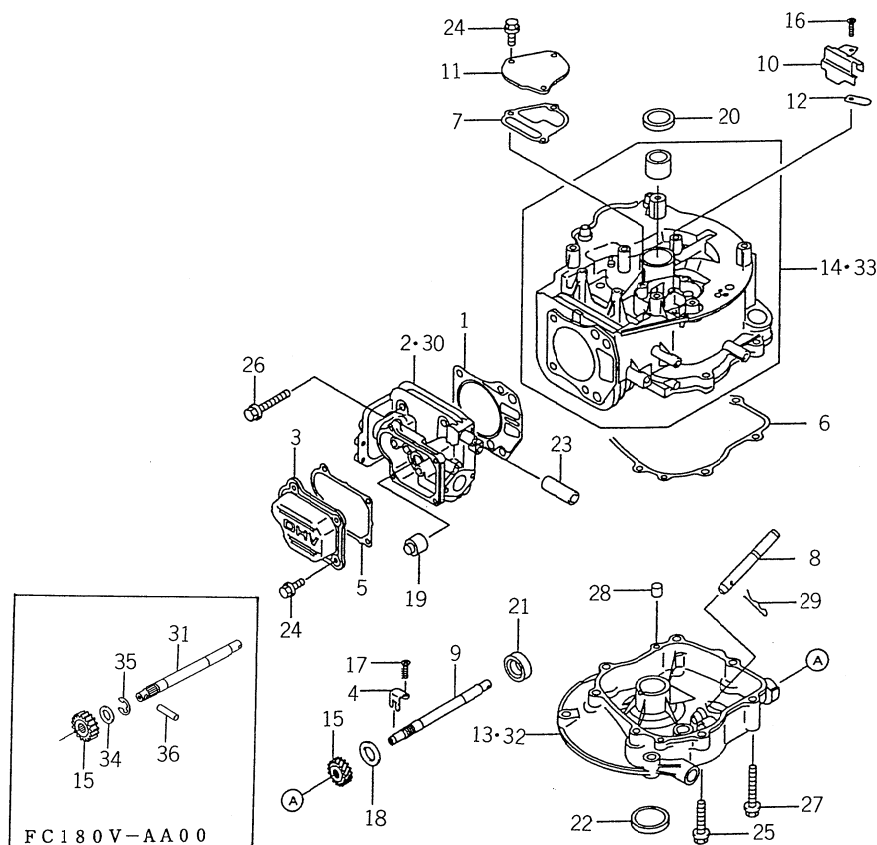

K621-0010

KEY Réf.	PART CODE Pièces No.	DESCRIPTION	Désignation	QTY Quant.	TYPE OF MODEL			Modél	I T C	C O L	G R P	REMARKS Remarques
					FC180V AA00	FC180V BA00	FC180V CA00					
1	5110-042-117-XX	GASKET-HEAD	Joint de cylindre	1	*	*	*					110042117
2	5110-082-117-XX	HEAD-COMP-CYLINDER	Culasse	1		*	*					110082117
3	5110-222-067-XX	CASE-ROCKER	Boitier	1	*	*	*					110222067
4	5110-492-019-XX	BRACKET	Support	1		*	*					110492019
5	5110-602-139-XX	GASKET-ROCKER CASE	Joint	1	*	*	*					110602139
6	5110-602-142-XX	GASKET-CRANKCASE	Joint	1	*	*	*					110602142
7	5110-602-143-XX	GASKET	Joint	1	*	*	*					110602143
8	5131-072-255-XX	SHAFT	Arbre	1	*	*	*					131072255
9	5131-072-272-XX	SHAFT	Arbre	1		*	*					131072272
10	5131-832-504-XX	PLATE	Praque	1	*	*	*					131832504
11	5140-902-032-XX	COVER	Capot	1	*	*	*					140902032
12	5161-262-146-XX	VALVE	Suupape	1	*	*	*					161262146
13	5490-152-338-XX	COVER-CRANKCASE	Carter	1		*	*					490152338
14	5491-206-112-XX	CRANKCASE-COMP	Carter	1		*	*					491206112
15	5590-562-790-XX	GEAR-HERICAL	Pignon	1	*	*	*					590562790
16	5920-092-166-XX	SCREW-5X8	Vis	1	*	*	*					920092166
17	5920-092-308-XX	SCREW	Vis	1		*	*					920092308
18	5920-222-69X-XX	WASHER	Rondelle	1		*	*					92022269
19	5920-491-062-XX	SEAL-OIL	Joint SPI	1	*	*	*					920491062
20	5920-492-199-XX	SEAL-OIL	Joint SPI	1	*	*	*					920492199
21	5920-492-204-XX	SEAL-OIL	Joint SPI	1	*	*	*					920492204
22	5920-492-210-XX	SEAL-OIL	Joint SPI	1	*	*	*					920492210
23	5921-902-112-XX	TUBE-12X16X46	Tuyau	1	*	*	*					921902112
24	5130-B06-12X-XX	BOLT-FLANGED	Vis	7	*	*	*					130B0612
25	5130-608-35X-XX	BOLT-FLANGED	Vis	4	*	*	*					130G0835

FIG. 7 CONTROL – EQUIPMENT

Commandes

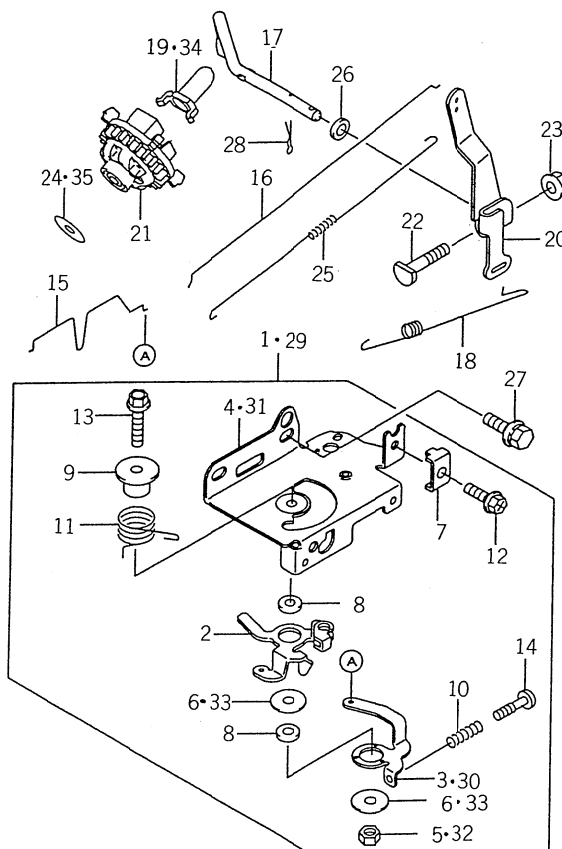

K621-0070

KEY Réf.	PART CODE Pièces No.	DESCRIPTION	Désignation	QTY Quant.	TYPE OF MODEL			I T C	C O L	G R P	REMARKS Remarques
					FC180V AA00	FC180V BAC0	Modél FC180V CA00				
1	5391-802-895-XX	PANEL-ASSY-CONTROL	Ens. panneau de commande	1		*	*				391802895
2	5131-682-352-XX	LEVER	Levier	1	*	*	*				131682352
3	5131-682-388-XX	LEVER	Levier	1		*	*				131682388
4	5592-262-291-XX	PANEL-CONTROL	Panneau de commande	1		*	*				592262291
5	5920-152-051-XX	NUT	Ecrou	1		*	*				920152051
6	5920-222-372-XX	WASHER-6X19X1.2	Rondelle	2		*	*				920222372
7	5920-372-209-XX	CLAMP	Attach	1	*	*	*				920372209
8	5921-432-135-XX	COLLAR-6X13X2.3	Entretoise	2	*	*	*				921432135
9	5921-432-148-XX	COLLAR	Entretoise	1	*	*	*				921432148
10	5921-442-266-XX	SPRING	Ressort	1	*	*	*				921442266
11	5921-442-316-XX	SPRING	Ressort	1	*	*	*				921442316
12	5921-502-182-XX	BOLT-5X18	Vis	1	*	*	*				921502182
13	5130-B06-30X-XX	BOLT-FLANGED	Vis	1	*	*	*				130B0630
14	5214-B04-20X-XX	SCREW-PAN	Vis	1	*	*	*				214B0420
15	5161-692-111-XX	LINK-CHOKE	Tige	1	*	*	*				161692111
16	5161-712-068-XX	LINK	Tige	1	*	*	*				161712068
17	5390-032-077-XX	ARM-PIVOT	Bras	1	*	*	*				390032077
18	5391-292-054-XX	SPRING-GOVERNOR	Ressort de regulateur	1	*	*	*				391292054
19	5420-362-051-XX	SLEEVE	Bague	1		*	*				420362051
20	5491-032-127-XX	ARM-GOVERNOR	Bras de regulateur	1	*	*	*				491032127
21	5491-102-080-XX	GOVERNOR-ASSY	Ens. regulateur	1	*	*	*				491102080
22	5920-022-269-XX	BOLT	Vis	1	*	*	*				920022269
23	5920-151-193-XX	NUT	Ecrou	1	*	*	*				920151193
24	5920-222-019-XX	WASHER	Rondelle	1		*	*				920222019
25	5921-442-329-XX	SPRING	Ressort	1	*	*	*				921442329

AFIG. 8 CARBURETOR

Carburateur

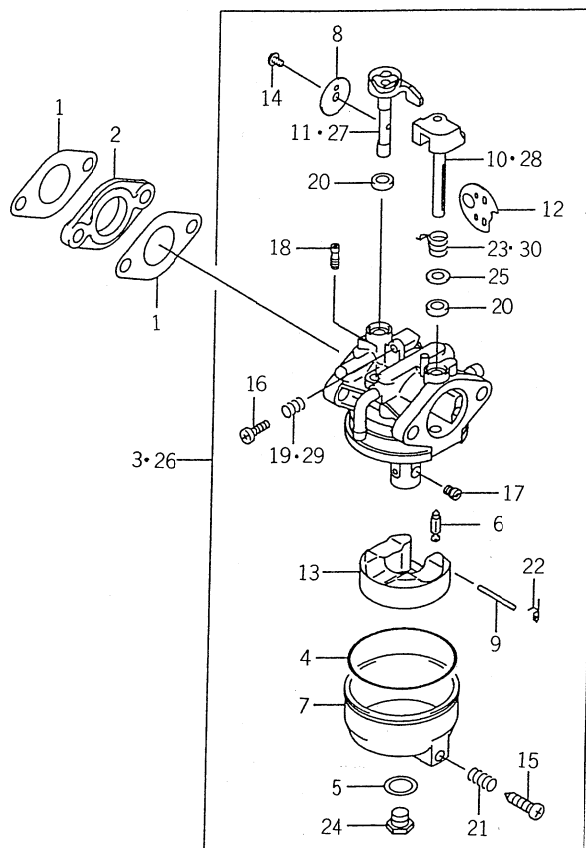

X621-0080

KEY Réf.	PART CODE Pièces No.	DESCRIPTION	Désignation	QTY Quant.	TYPE OF MODEL			I T C	C O L	G R P	REMARKS Remarques
					FC180V AA00	FC180V BA00	Modél FC180V CA00				
1	5110-602-144-XX	GASKET-CARBURETOR	Joint	2	*	*	*				110602144
2	5160-732-164-XX	INSULATOR	Ecran thermique	1	*	*	*				160732164
3	5150-032-351-XX	CARBURETOR-ASSY	Ens. carburateur	1		*	*				150032351
4	5110-602-190-XX	GASKET	Joint	1	*	*	*				110602190
5	5110-602-191-XX	GASKET	Joint	1	*	*	*				110602191
6	5160-092-136-XX	NEEDLE-JET	Pointeau de buse	1	*	*	*				160092136
7	5160-202-129-XX	CHAMBER-FLOAT	Chambre du flotteur	1	*	*	*				160202129
8	5160-252-166-XX	VALVE-THROTTLE	Boisseau	1	*	*	*				160252166
9	5160-412-224-XX	SHAFT-CARBURETOR	Axe papillon	1	*	*	*				160412224
10	5160-412-231-XX	SHAFT-CARBURETOR	Axe papillon	1		*	*				160412231
11	5160-412-244-XX	SHAFT-CARBURETOR	Axe papillon	1		*	*				160412244
12	5161-262-191-XX	VALVE-CHOKE	Volet d'air	1	*	*	*				161262191
13	5161-832-002-XX	FLOAT-ASSY	Flotteur	1	*	*	*				161832002
14	5230-132-058-XX	SCREW-ASSY	Vis	1	*	*	*				230132058
15	5920-092-348-XX	SCREW	Vis	1	*	*	*				920092348
16	5920-092-349-XX	SCREW	Vis	1	*	*	*				920092349
17	5920-632-242-XX	JET-MAIN 92	Gicleur principal	1	*	*	*				920632242
18	5920-642-094-XX	JET-PILOT 44	Vis de melange	1	*	*	*				920642094
19	5920-812-234-XX	SPRING	Ressort	1		*	*				920812234
20	5920-932-100-XX	SEAL	Joint	2	*	*	*				920932100
21	5921-442-333-XX	SPRING	Ressort	1	*	*	*				921442333
22	5921-442-335-XX	SPRING	Ressort	1	*	*	*				921442335
23	5921-442-364-XX	SPRING	Ressort	1		*	*				921442364
24	5921-502-263-XX	BOLT	Vis	1	*	*	*				921502263
25	5922-002-061-XX	WASHER-9.8X5.5X1.0	Rondelle	1	*	*	*				922002061

ENGINE

FC180V – AB00, BB00

FIG. 1 CYLINDER/CRANKCASE
Cylindre/Carter

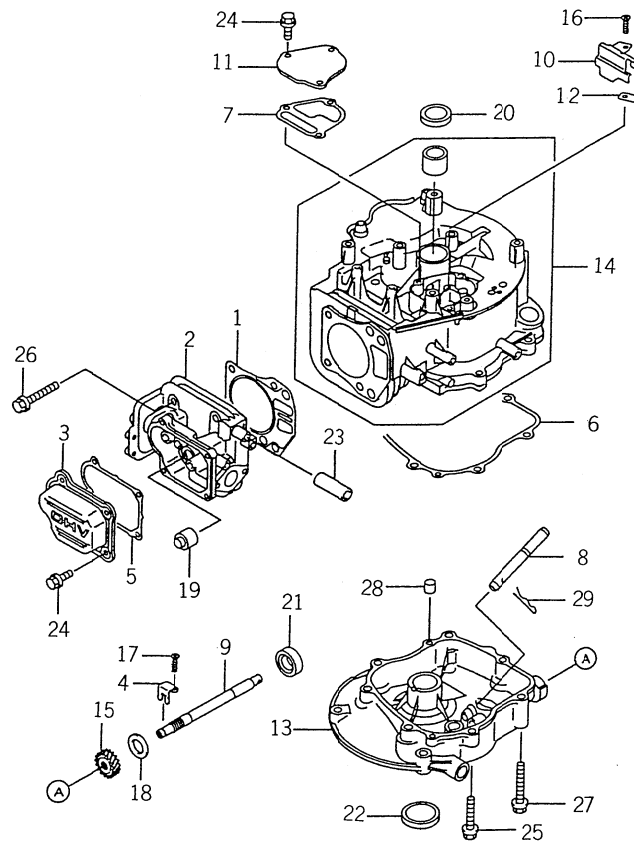

K621-0010

KEY Réf.	PART CODE Pièces No.	DESCRIPTION	Désignation	QTY Quant.	TYPE OF MODEL		Modél	I T C	C O L	G R P	REMARKS Remarques
					FC180V AB00	FC180V BB00					
1	5110-042-117-XX	GASKET-HEAD	Joint de cylindre	1	*	*					110042117
2	5110-082-117-XX	HEAD-COMP-CYLINDER	Culasse	1	*	*					110082117
3	5110-222-067-XX	CASE-ROCKER	Boitier	1	*	*					110222067
4	5110-492-019-XX	BRACKET	Support	1	*	*					110492019
5	5110-602-139-XX	GASKET-ROCKER CASE	Joint	1	*	*					110602139
6	5110-602-142-XX	GASKET-CRANKCASE	Joint	1	*	*					110602142
7	5110-602-143-XX	GASKET	Joint	1	*	*					110602143
8	5131-072-255-XX	SHAFT	Arbre	1	*	*					131072255
9	5131-072-272-XX	SHAFT	Arbre	1	*	*					131072272
10	5131-832-504-XX	PLATE	Praque	1	*	*					131832504
11	5140-902-032-XX	COVER	Capot	1	*	*					140902032
12	5161-262-146-XX	VALVE	Soupape	1	*	*					161262146
13	5490-152-338-XX	COVER-CRANKCASE	Carter	1	*	*					490152338
14	5491-206-112-XX	CRANKCASE-COMP	Carter	1	*	*					491206112
15	5590-562-790-XX	GEAR-HERICAL	Pignon	1	*	*					590562790
16	5920-092-166-XX	SCREW-5X8	Vis	1	*	*					920092166
17	5920-092-308-XX	SCREW	Vis	1	*	*					920092308
18	5920-222-69X-XX	WASHER	Rondelle	1	*	*					92022269
19	5920-491-062-XX	SEAL-OIL	Joint SPI	1	*	*					920491062
20	5920-492-199-XX	SEAL-OIL	Joint SPI	1	*	*					920492199
21	5920-492-204-XX	SEAL-OIL	Joint SPI	1	*	*					920492204
22	5920-492-210-XX	SEAL-OIL	Joint SPI	1	*	*					920492210
23	5921-902-112-XX	TUBE-12X16X46	Tuyau	1	*	*					921902112
24	5130-B06-12X-XX	BOLT-FLANGED	Vis	7	*	*					130B0612
25	5130-G08-35X-XX	BOLT-FLANGED	Vis	4	*	*					130G0835

FIG. 6 ELECTRIC – EQUIPMENT Électricité

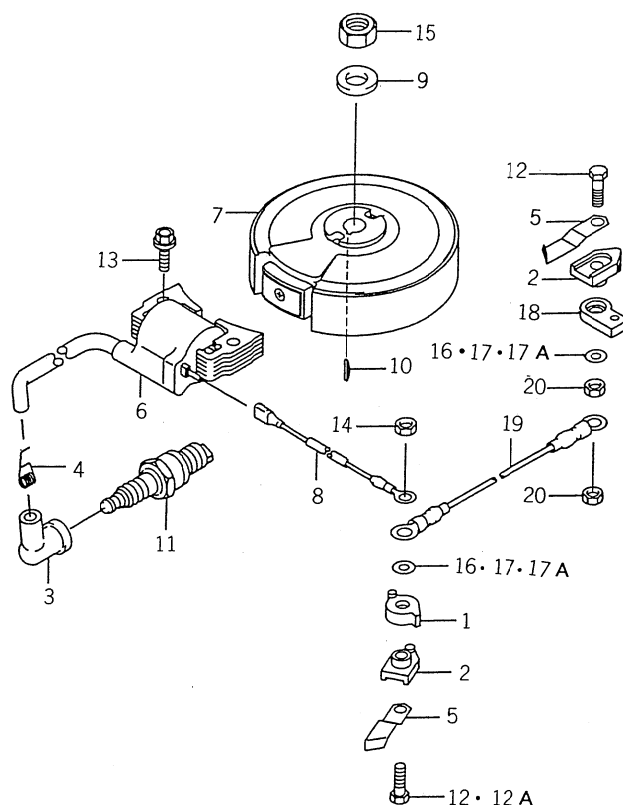

K621-0060

KEY Réf.	PART CODE Pièces No.	DESCRIPTION	Désignation	QTY Quant.	TYPE OF MODEL		Modél	I T C	C O L	G R P	REMARKS Remarques
					FC180V AB00	FC180V BB00					
1	5140-242-183-XX	COVER	Capot	1	*	*					140242183
2	5160-732-165-XX	INSULATOR	Ecran thermique	2	*	*					160732165
3	5211-302-066-XX	CAP-SPARK PLUG	Capuchon	1	*	*					211302066
4	5211-692-004-XX	TERMINAL	Borne	1	*	*					211692004
5	5211-692-066-XX	TERMINAL	Borne	2	*	*					211692066
6	5211-712-200-XX	COIL-ASSY-IGNITION	Ens. bobine d'allumage	1	*	*					211712200
7	5211-942-292-XX	FLYWHEEL-COMP	Ens. volant	1	*	*					211942292
8	5260-112-306-XX	WIRE-LEAD	Fil	1	*	*					260112306
9	5920-222-102-XX	WASHER	Rondelle	1	*	*					920222102
10	5920-382-077-XX	KEY	Clavette	1	*	*					920382077
11	5920-701-167-XX	PLUG-SPARK-BP5ES	Bougie	1	*	*					920701167
12	5921-502-300-XX	BOLT-4X20	Vis	1	*	1- -017986 017987-					921502300
12A	5112-B05-22X-XX	BOLT-UPSET	Vis	1							112B0522
13	5130-G06-25X-XX	BOLT-FLANGED	Vis	2	*	*					130G0625
14	5311-B04-00X-XX	NUT-HEX	Ecrou	1		*					311B0400
15	5314-G14-00X-XX	NUT-HEX-FINE	Ecrou	1	*	*					314G1400
16	5410-B04-00X-XX	W-PLAIN-S	Rondelle	1	*	*					410B0400
17	5410-B05-00X-XX	W-PLAIN-S	Rondelle	1	*	1- -017986 017987-					410B0500
17A	5411-B04-00X-XX	WASHER-PLAIN	Rondelle	1							411B0400
18	5160-732-123-XX	INSULATOR	Ecran thermique	1	*	*					160732123
19	5260-112-323-XX	WIRE-LEAD	Fil	1	*	*					260112323
20	5311-B05-00X-XX	NUT-HEX	Ecrou	2	*	*					311B0500

FIG. 7 CONTROL – EQUIPMENT

Commandes

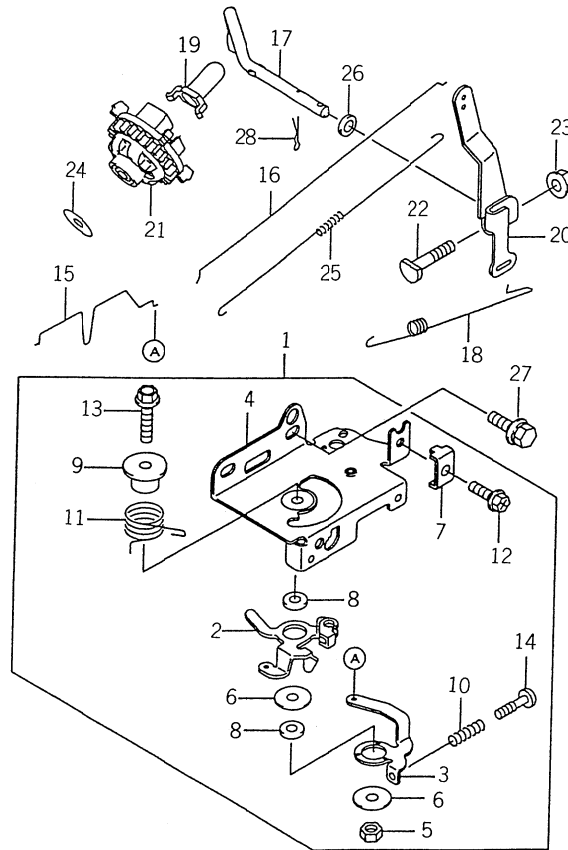

K621-0070

KEY Réf.	PART CODE Pièces No.	DESCRIPTION	Désignation	QTY Quant.	TYPE OF MODEL		Modél	I T C	C O L	G R P	REMARKS Remarques
					FC180V AB00	FC180V BB00					
1	5391-802-895-XX	PANEL-ASSY-CONTROL	Ens. panneau de commande	1	*	*					391802895
2	5131-682-352-XX	LEVER	Levier	1	*	*					131682352
3	5131-682-388-XX	LEVER	Levier	1	*	*					131682388
4	5592-262-291-XX	PANEL-CONTROL	Panneau de commande	1	*	*					592262291
5	5920-152-051-XX	NUT	Ecrou	1	*	*					920152051
6	5920-222-372-XX	WASHER-6X19X1.2	Rondelle	2	*	*					920222372
7	5920-372-209-XX	CLAMP	Attache	1	*	*					920372209
8	5921-432-135-XX	COLLAR-6X13X2.3	Entretoise	2	*	*					921432135
9	5921-432-148-XX	COLLAR	Entretoise	1	*	*					921432148
10	5921-442-266-XX	SPRING	Ressort	1	*	*					921442266
11	5921-442-316-XX	SPRING	Ressort	1	*	*					921442316
12	5921-502-182-XX	BOLT-5X18	Vis	1	*	*					921502182
13	5130-B06-30X-XX	BOLT-FLANGED	Vis	1	*	*					130B0630
14	5214-B04-20X-XX	SCREW-PAN	Vis	1	*	*					214B0420
15	5161-692-111-XX	LINK-CHOKE	Tige	1	*	*					161692111
16	5161-712-068-XX	LINK	Tige	1	*	*					161712068
17	5390-032-077-XX	ARM-PIVOT	Bras	1	*	*					390032077
18	5391-292-054-XX	SPRING-GOVERNOR	Ressort de regulateur	1	*	*					391292054
19	5420-362-051-XX	SLEEVE	Bague	1	*	*					420362051
20	5491-032-127-XX	ARM-GOVERNOR	Bras de regulateur	1	*	*					491032127
21	5491-102-080-XX	GOVERNOR-ASSY	Ens. regulateur	1	*	*					491102080
22	5920-022-269-XX	BOLT	Vis	1	*	*					920022269
23	5920-151-193-XX	NUT	Ecrou	1	*	*					920151193
24	5920-222-019-XX	WASHER	Rondelle	1	*	*					920222019
25	5921-442-329-XX	SPRING	Ressort	1	*	*					921442329

FIG. 8 CARBURETOR

Carburateur

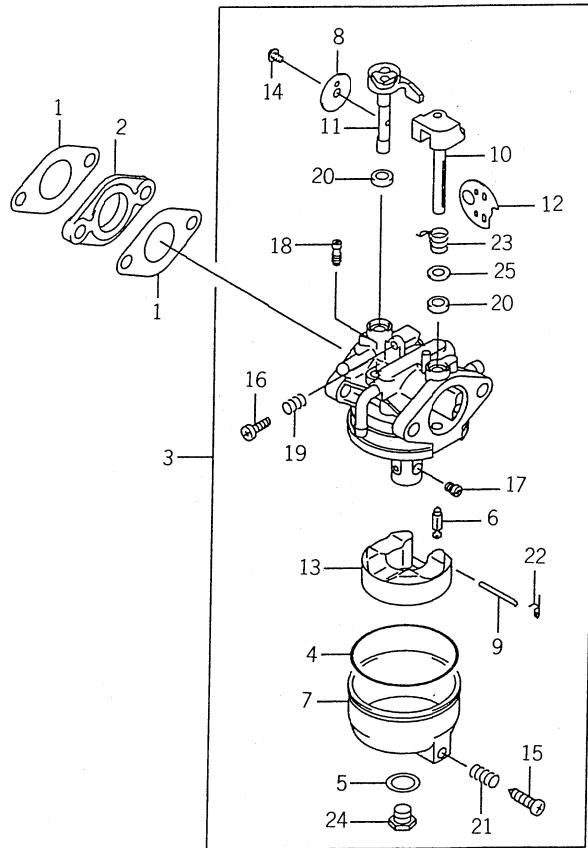

K621-0080

KEY Réf.	PART CODE Pièces No.	DESCRIPTION	Désignation	QTY Quant.	TYPE OF MODEL			I T C	C O L	G R P	REMARKS Remarques
					FC180V AB00	FC180V BB00	Modél				
1	5110-602-144-XX	GASKET-CARBURETOR	Joint	2	*	*					110602144
2	5160-732-164-XX	INSULATOR	Ecran thermique	1	*	*					160732164
3	5150-032-351-XX	CARBURETOR-ASSY	Ens. carburateur	1	*	*					150032351
4	5110-602-190-XX	GASKET	Joint	1	*	*					110602190
5	5110-602-191-XX	GASKET	Joint	1	*	*					110602191
6	5160-092-136-XX	NEEDLE-JET	Pointeau de buse	1	*	*					160092136
7	5160-202-129-XX	CHAMBER-FLOAT	Chambre du flotteur	1	*	*					160202129
8	5160-252-166-XX	VALVE-THROTTLE	Boisseau	1	*	*					160252166
9	5160-412-224-XX	SHAFT-CARBURETOR	Axe papillon	1	*	*					160412224
10	5160-412-231-XX	SHAFT-CARBURETOR	Axe volet d'air	1	*	*					160412231
11	5160-412-244-XX	SHAFT-CARBURETOR	Axe volet d'air	1	*	*					160412244
12	5161-262-191-XX	VALVE-CHOKE	Volet d'air	1	*	*					161262191
13	5161-832-002-XX	FLOTT-ASSY	Flotteur	1	*	*					161832002
14	5230-132-058-XX	SCREW-ASSY	Vis	1	*	*					230132058
15	5920-092-348-XX	SCREW	Vis	1	*	*					920092348
16	5920-092-349-XX	SCREW	Vis	1	*	*					920092349
17	5920-632-242-XX	JET-MAIN 92	Gicleur principal	1	*	*					920632242
18	5920-642-094-XX	JET-PILOT 44	Vis de melange	1	*	*					920642094
19	5920-812-234-XX	SPRING	Ressort	1	*	*					920812234
20	5920-932-100-XX	SEAL	Joint	2	*	*					920932100
21	5921-442-333-XX	SPRING	Ressort	1	*	*					921442333
22	5921-442-335-XX	SPRING	Ressort	1	*	*					921442335
23	5921-442-364-XX	SPRING	Ressort	1	*	*					921442364
24	5921-502-263-XX	BOLT	Vis	1	*	*					921502263
25	5922-002-061-XX	WASHER-9. 8X5. 5X1. 0	Rondelle	1	*	*					922002061

CHASSIS

FIG. 6 CASE SYSTEM
Boitier

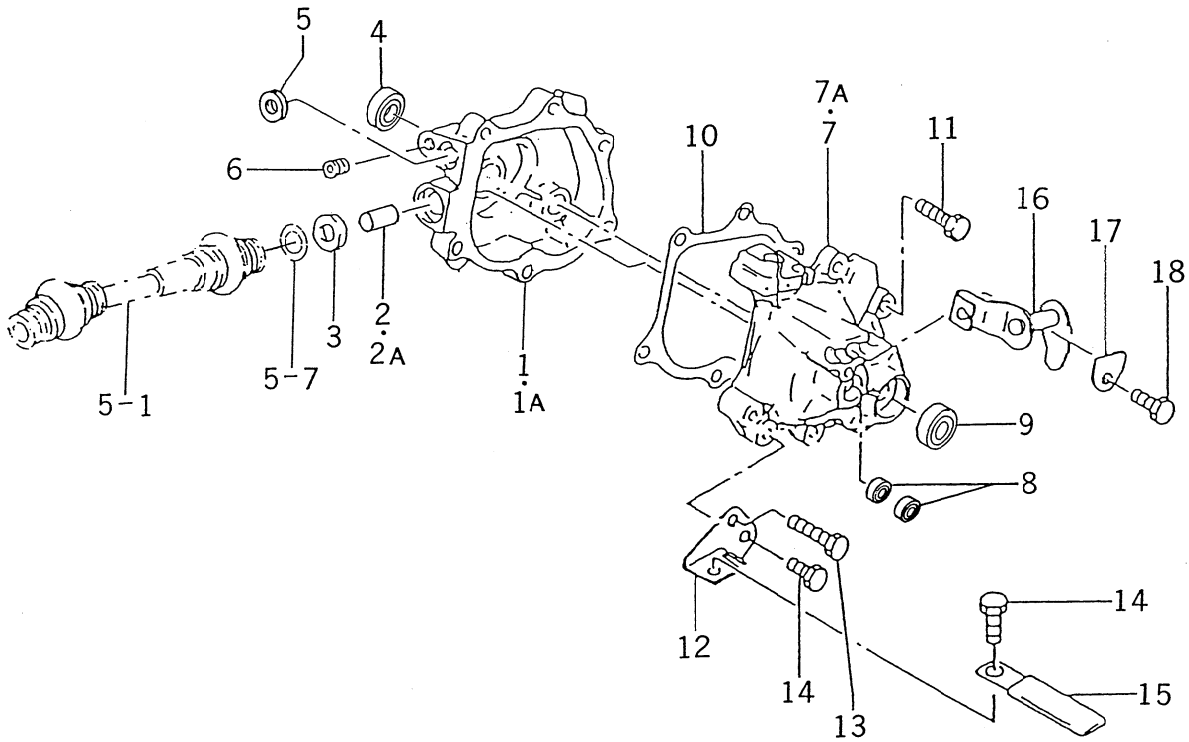

2500-360

KEY Réf.	PART CODE Pièces No.	DESCRIPTION	Désignation	QTY Quant.	TYPE OF MODEL			Modél	I T C	C O L	G R P	REMARKS Remarques
					BE01	E01						
1	2500-360-002-00	CASE, MISSION/RH	Ensemble boitier	1	1- -102704	1- -104712						
1A	2500-360-002-10	CASE, MISSION/RH	Ensemble boitier	1	102705-	104713-						
2	2500-360-004-10	BEARING, NEEDLL	Roulement	1	1- -102704	1- -104712						
2A	V653-410-172-00	BEARING, NEEDLL	Roulement	1	102705-	104713-						
3	2500-310-008-00	SEAL, OIL	Joint SPI	1	*	*						
4	V744-112-220-70	SEAL, OIL	Joint SPI	1	*	*						
5	2500-310-009-10	SEAL, OIL	Joint SPI	1	*	*						
6	V780-140-000-2B	BOLT, RAPPING, PT1/8	Vis	1	*	*						
7	2500-310-001-00	CASE, MISSION/LH	Boitier	1	1- -102704	1- -104712						
7A	2500-310-001-10	CASE, MISSION/LH	Boitier	1	102705-	104713-						
8	2500-310-009-10	SEAL, OIL	Joint SPI	3	*	*						
9	V744-112-220-70	SEAL, OIL	Joint SPI	1	*	*						
10	2500-310-003-00	GASKET	Joint	1	*	*						
11	2500-310-006-00	BOLT, TA00ING/06X25	Vis	5	*	*						
12	2500-310-005-10	PLATE	Plaque	1	*	*						
13	2500-310-012-00	BOLT, TAPPING/06X35	Vis	1	*	*						
14	2500-210-005-00	BOLT, TAPPING/06X16	Vis	2	*	*						
15	3768-172-008-00	CLAMP/7	Attache	1		*						
16	2500-310-200-00	SHIFTER	Fouchette complet	1	*	*						
17	2500-310-007-00	HOLDER	Support	1	*	*						
18	2500-210-005-00	BPLT, TAPPING/06X16	Vis	1	*	*						

FIG. 7 GEAR SYSTEM
Pignonnerie

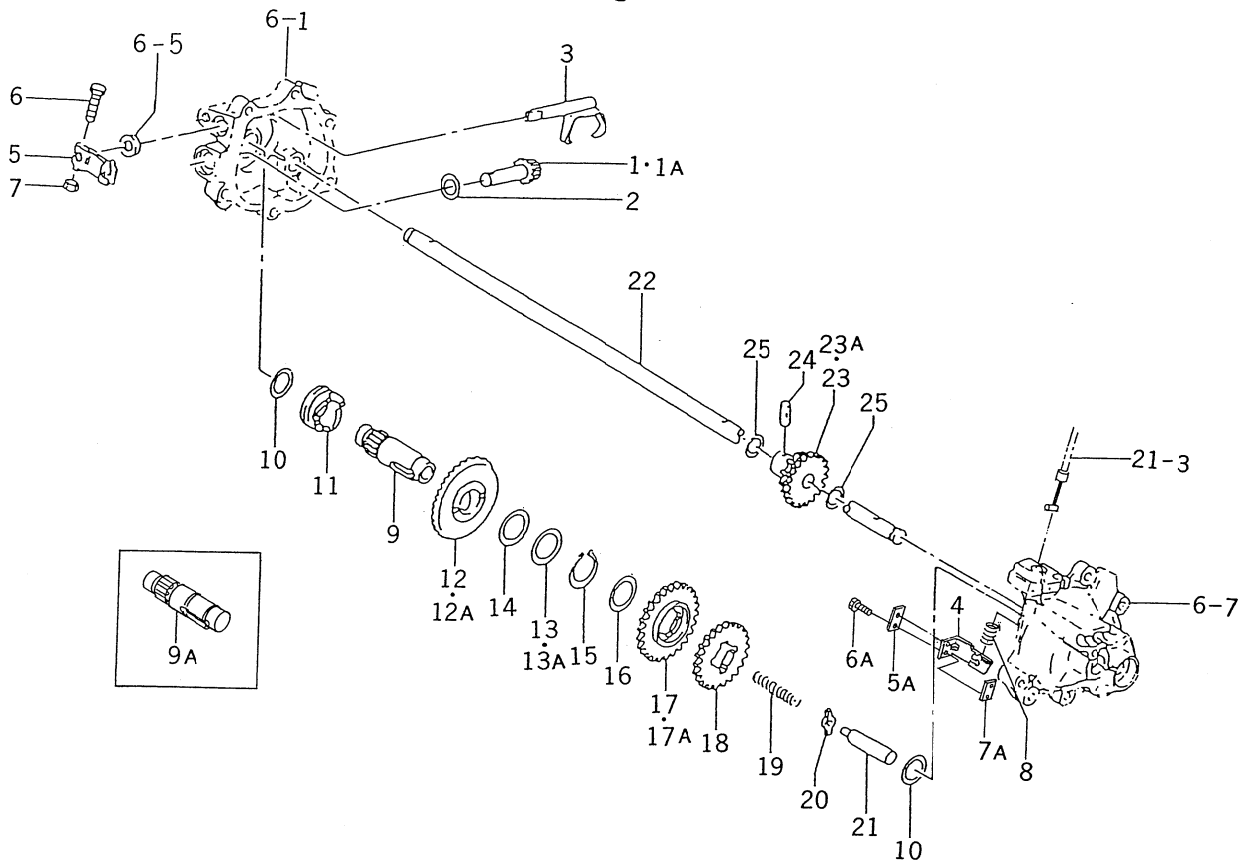

2500-361

KEY Réf.	PART CODE Pièces No.	DESCRIPTION	Désignation	QTY Quant.	TYPE OF MODEL		Modél	I T C	C O L	G R P	REMARKS Remarques
					BE01	E01					
1	2500-311-001-00	GEAR, BEVEL/14	Pignon	1	1- -300150 300151-	1- -300150 300151-					
1A	2500-311-001-10	GEAR, BEVEL/14	Pignon	1	*	*					
2	2500-510-006-00	WASHER/11X20X01	Rondelle	1	*	*					
3	2500-311-200-00	SHIFTER	Fouchette complet	1	*	*					
4	2500-361-021-00	ARM, CLUTCH	Bras	1	*	*					
5	2500-311-021-00	ARM, CLUTCH	Bras	1	1- -300150 300151-	1- -300150 300151-					
5A	2500-361-023-00	PLATE, I/13X22	Plaque	1	*	*					
6	2500-311-022-00	BOLT/M05X20	Vis	1	1- -300150 300151-	1- -300150 300151-					
6A	V200-260-501-60	BOLT/M05X20	Vis	2	*	*					
7	V301-260-005-00	NUT/M5	Ecrou	1	1- -300150 300151-	1- -300150 300151-					
7A	2500-361-024-00	PLATE, I/13X22	Plaque	1	*	*					
8	2500-311-015-10	SPRING/HC039	Ressort	1	*	*					
9	2500-311-005-10	SHAFT, INPUT	Arbre	1	1- -300000 300001-	1- -300000 300001-					
9A	2500-311-005-20	SHAFT, INPUT	Arbre	1	*	*					
10	2500-311-013-00	WASHER/17X24X01	Rondelle	2	*	*					
11	2500-311-003-00	CAM, DRIVE CLUTCH	Cames	1	*	*					
12	2500-311-002-00	GEAR, BEVEL/55	Pignon	1	1- -300000 300001-	1- -300000 300001-					
12A	2500-311-002-10	GEAR, BEVEL/55	Pignon	1	*	*					
13	2500-311-018-00	SHIM/0.5	Rondelle	1	1- -300000 300001-	1- -300000 300001-					
13A	2500-311-019-00	SHIM/0.3X20X30	Rondelle	1	*	*					
14	1365-224-002-00	WASHER	Rondelle	2	*	*					
15	V704-140-020-00	RING, SNAP/20	Circrrips	1	*	*					
16	1365-224-002-00	WASHER	Rondelle	1	*	*					
17	2500-361-006-10	GEAR, SPUR/31	Pignon	1	1- -102904 120995-	1- -104712 104713-					
17A	2500-361-006-20	GEAR, SPUR/31	Pignon	1	*	*					

FIG. 7 GEAR SYSTEM

Pignonnerie

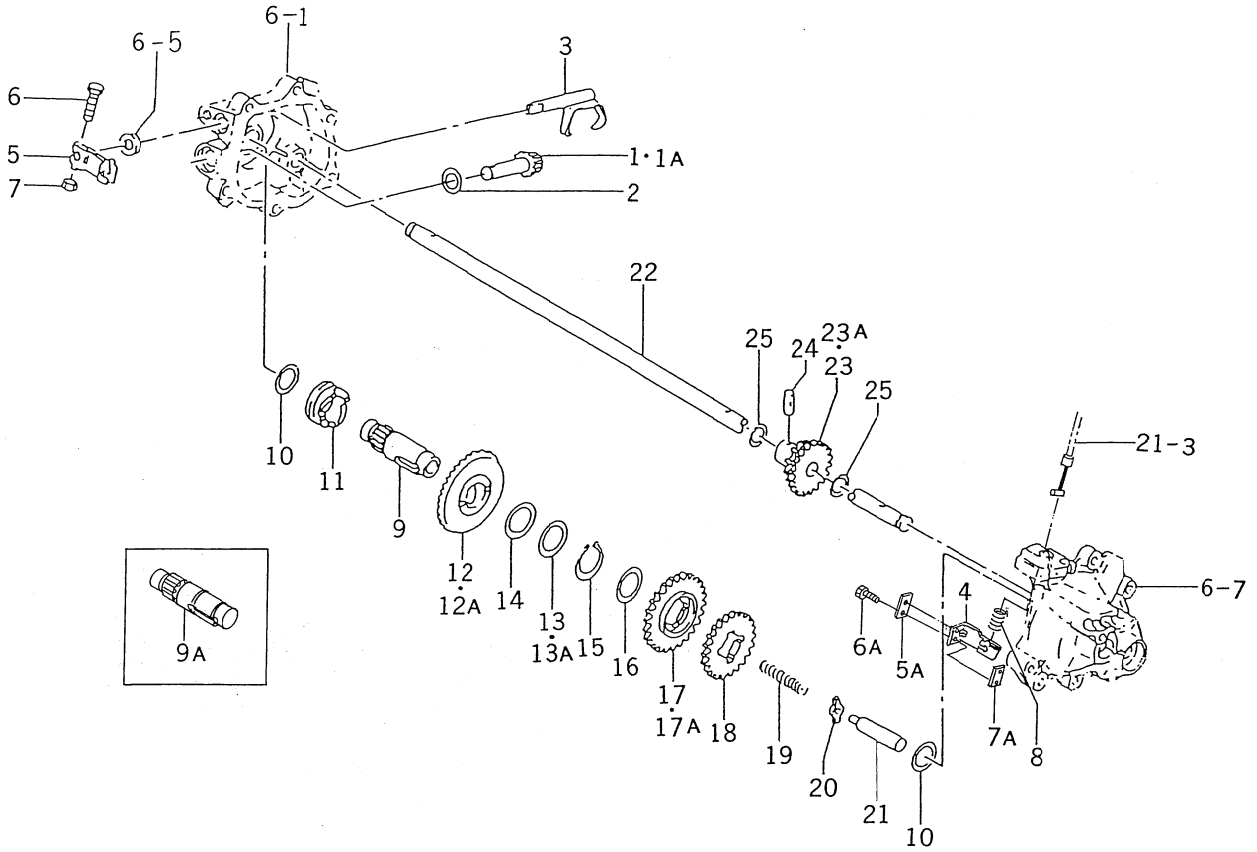

2500-361

KEY Réf.	PART CODE Pièces No.	DESCRIPTION	Désignation	QTY Quant.	TYPE OF MODEL			Modél	I T C	C O L	G R P	REMARKS Remarques
					BE01	E01						
18	2500-311-007-00	GEAR, SPUR/26	Pignon	1	*	*						
19	2500-311-016-00	SPRING/HC048	Ressort	1	*	*						
20	2500-311-017-00	CAM, SHIFT	Cames	1	*	*						
21	2500-311-008-00	PIN,/08X49	Axe	1	*	*						
22	2500-311-009-10	SHAFT, WHEEL	Arbre	1	*	*						
23	2500-361-011-00	GEAR, OUTPUT	Pignon	1	1- -102904 102905-	1- -104712 104713-						
23A	2500-361-011-10	GEAR, OUTPUT	Pignon	1								
24	2500-311-004-00	PIN, /05X22	Axe	1	*	*						
25	2500-311-012-00	WASHER,/12X21X01	Rondelle	2	*	*						

FIG. 8 WHEEL/REAR SYSTEM
Roue arrière

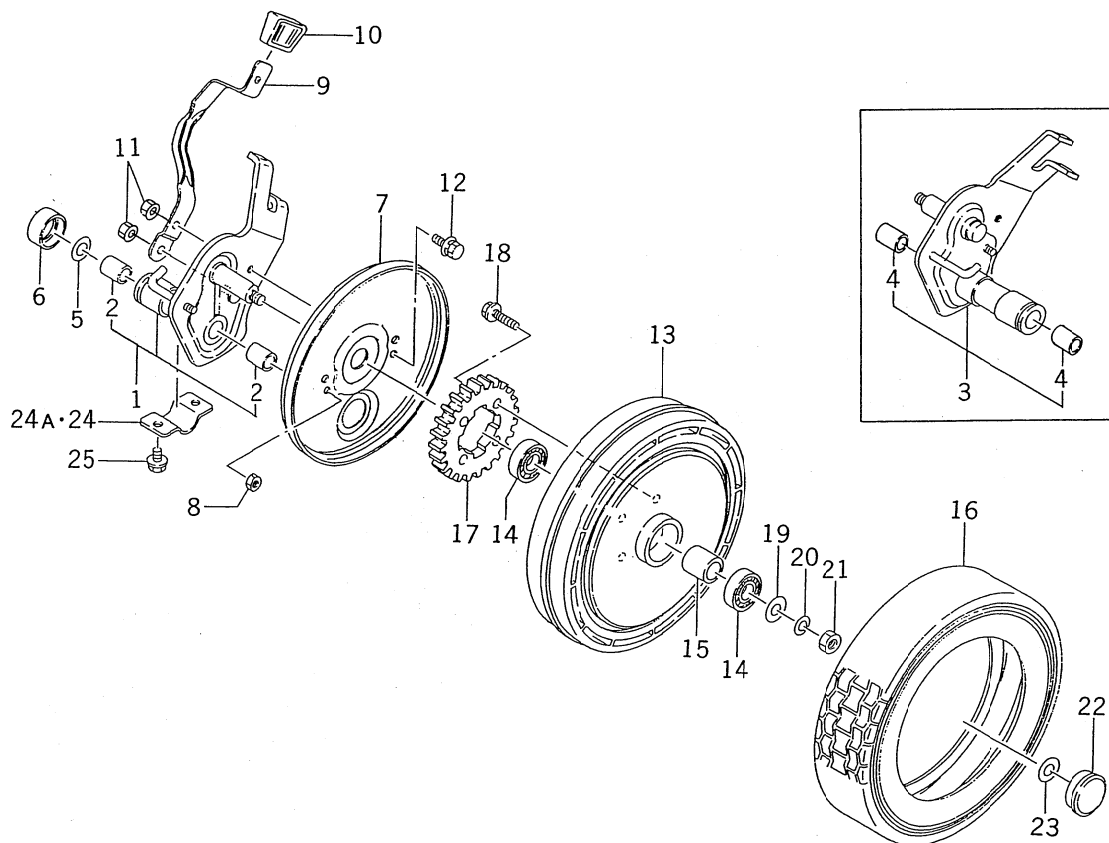

2500-376

KEY Réf.	PART CODE Pièces No.	DESCRIPTION	Désignation	QTY Quant.	TYPE OF MODEL		Modél	I T C	C O L	G R P	REMARKS Remarques
					BE01	E01					
1	2500-376-230-00	BRACKET, R WHEEL	Support	1	*	*					
2	2500-376-008-20	BUSH/12X15X20	Douille	2	*	*					
3	2500-376-240-00	BRACKET, R WHEEL	Support	1	*	*					
4	2500-376-008-20	BUSH/12X15X20	Douille	2	*	*					
5	2500-311-012-00	WASHER/12X21X01	Rondelle	4	*	*					
6	2500-326-021-00	CAP	Capuchon	2	*	*					
7	2500-376-012-10	COVER, WHEEL	Couvercle	2	*	*					
8	2500-326-017-00	NUT, FLANGE/M06	Ecrou	2	*	*					
9	2500-376-013-20	LEVER, SPRING, REAR	Leiver	2	*	*					
10	2500-326-014-00	GRIP	Poignee	2	*	*					
11	2500-326-017-00	NUT, FLANGE/M06	Ecrou	4	*	*					
12	V210-360-601-60	BOLT, SP/M6X16	Vis	2	*	*					
13	2500-376-001-20	WHEEL	Ens. roue arriere	2	*	*					
14	V600-150-600-20	R. B. B	Roulement a billes	4	*	*					
15	2500-376-004-00	COLLAR/16X22X22	Douille	2	*	*					
16	2500-376-006-20	TIER/9X2.5	Pneu	2	*	*					
17	2500-326-002-00	GEAR, SPUR/42	Pignon	2	*	*					
18	2500-310-006-00	BOLT, TAPPING/06X25	Vis	8	*	*					
19	1373-121-001-00	WASHER/9X22X2	Rondelle	2	*	*					
20	V401-160-008-00	S. W	Rondelle	2	*	*					
21	V304-260-008-00	NUT/M8	Ecrou	2	*	*					
22	2706-301-020-00	CAP, WHEEL	Capuchon	2	*	*					
23	3747-342-002-00	WASHER	Rondelle	2	*	*					
24	2500-326-009-00	HOLDER, BRACKET,	Support	2	1- -102704	1- -104712					
24A	2500-326-009-10	HOLDER, BRACKET,	Support	2	102705-	104713-					

FIG. 9 WHEEL/FRONT SYSTEM
Roue avant

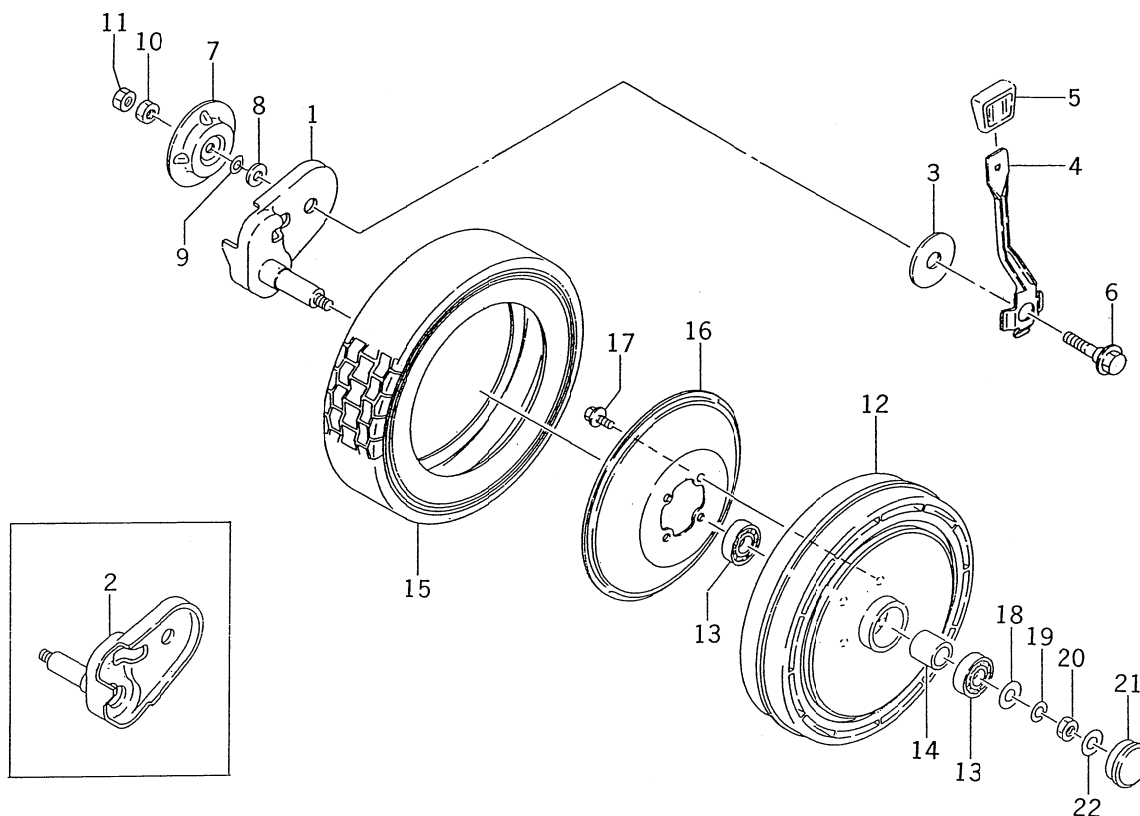

2500-386

KEY Réf.	PART CODE Pièces No.	DESCRIPTION	Désignation	QTY Quant.	TYPE OF MODEL		Modél	I T C	C O L	G R P	REMARKS Remarques
					BE01	E01					
1	2500-386-200-30	BRACKET, F WHEEL	Support, roue AV. G.	1	*	*					
2	2500-386-210-30	BRACKET, F WHEEL	Support, roue AV. D.	1	*	*					
3	2500-386-007-10	WASHER/13X46X01	Rondelle	2	*	*					
4	2500-386-004-40	LEVER, SPRING, FRONT	Levier	2	*	*					
5	2500-326-014-00	GRIP	Poignee	2	*	*					
6	2500-386-002-30	BOLT/M08X45	Vis	2	*	*					
7	2500-386-005-10	PLATE, CAP	Plaque	2	*	*					
8	1105-712-004-00	WASHER/08X18X2	Rondelle	2	*	*					
9	1338-301-005-00	WASHER	Rondelle	2	*	*					
10	2500-386-001-00	NUT/M08	Ecrou	2	*	*					
11	V304-260-008-00	NUT/M8	Ecrou	2	*	*					
12	2500-376-001-20	WHEEL	Ens. roue avant	2	*	*					
13	V600-150-600-20	R. B. B	Roulement a dilles	4	*	*					
14	2500-376-004-00	COLLAR/16X22X22	Douille	2	*	*					
15	2500-376-006-20	TIAR/9X2.5	Pneu	2	*	*					
16	2500-386-012-10	COVER, WHEEL, FRONT	Couvercle	2	*	*					
17	2500-401-006-00	BOLT, TAPPING/06X12	Vis	8	*	*					
18	1373-121-001-00	WASHER/9X22X2	Rondelle	2	*	*					
19	V401-160-008-00	S. W	Rondelle	2	*	*					
20	V304-260-008-00	NUT/M8	Ecrou	2	*	*					
21	2706-301-020-00	CAP, WHEEL	Capuchon	2	*	*					
22	3747-342-002-00	WASHER	Rondelle	2	*	*					

FIG. 14 LEVER SYSTEM (EXCEPT B TYPE)
Levier (excepté modèle B)

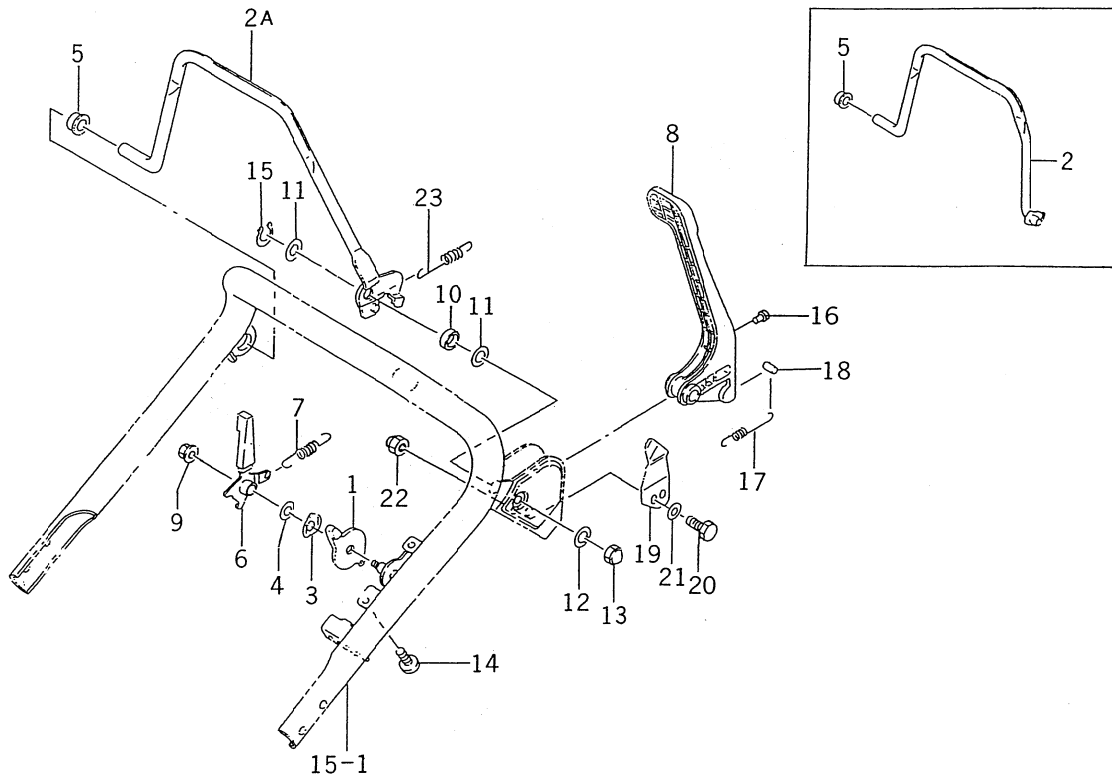

2500-515

KEY Réf.	PART CODE Pièces No.	DESCRIPTION	Désignation	QTY Quant.	TYPE OF MODEL			I T C	C O L	G R P	REMARKS Remarques
					BE01	E01	Modél				
1	2500-510-011-00	LEVER, AXLE	Levier	1	*						
2	2500-515-230-10	LEVER, PIPE/E	Levier	1	1- -300000						
2A	2500-560-230-20	LEVER	Levier	1	300001-						
3	2500-510-005-00	SPRING, DISK/10	Ressort	1	*						
4	2500-510-006-00	WASHER/11X20X01	Rondelle	1	*						
5	2500-510-013-00	BUSH/14X20X11	Douille	1	*						
6	2500-510-220-00	LEVER, CHANGE	Levier	1	*						
7	2500-510-051-10	SPRING/HE077	Ressort	1	*						
8	2500-510-240-10	LEVER, BBC	Levier	1	*						
9	2500-326-017-00	NUT, FLANGE/M06	Ecrou	1	*						
10	2503-510-004-20	COLLAR/15X20X08	Rondelle	1	*						
11	1427-601-003-00	WASHER/15X24X2	Rondelle	2	*						
12	V401-160-008-00	S. W	Rondelle	1	*						
13	V341-120-008-00	NUT/M8	Ecrou	1	*						
14	2500-510-002-00	SCREW, TAPPING/05X16	Vis	2	*						
15	V704-140-014-00	RING, SNAP/14	Circrips	1	*						
16	1527-604-002-00	CLIP, TRIM/8	Attache	1	*						
17	2500-515-001-00	SPRING/HE145	Ressort	1	*						
18	2500-210-008-00	PIN/08X14	Axe	1	*						
19	2500-501-002-10	PLATE, SPRING	Plaque	1	*						
20	V200-260-601-00	BOLT/M6X10	Vis	2	*						
21	V411-260-006-00	WASHER/M6	Rondelle	2	*						
22	V340-120-006-00	NUT, CAP/M6	Ecrou	2	*						
23	2500-510-051-10	SPRING/HE077	Ressort	1	*						

FIG. 23 MARK • LABEL SYSTEM Etiquettes

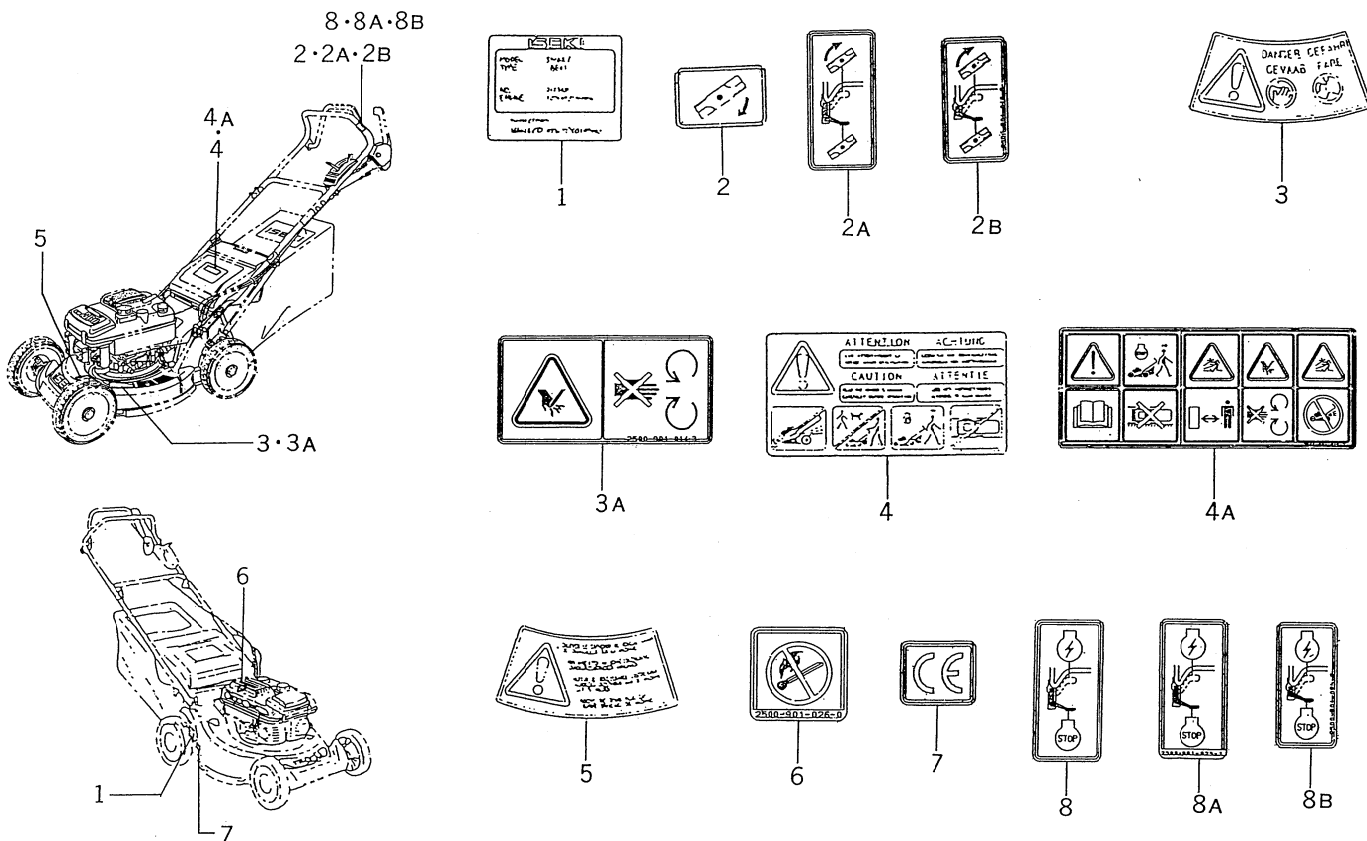

2500-901A

KEY Réf.	PART CODE Pièces No.	DESCRIPTION	Désignation	QTY Quant.	TYPE OF MODEL		Modél	I T C	C O L	G R P	REMARKS Remarques
					BE01	E01					
1	J910-000-200-00	LABEL, MODEL	Etiquette	1	*	*					
2	2500-901-018-00	LABEL/BBC	Etiquette	1		1- -300000					
2A	2500-901-018-10	LABEL/BBC	Etiquette	1		300001- -300390					
2B	2500-901-018-30	LABEL/BBC	Etiquette	1		300391-					
3	2500-901-014-20	LABEL, DANBER	Etiquette	2	*	1- -300000					
3A	2500-901-014-30	LABEL, DANGER	Etiquette	2	*	300001-					
4	2500-901-015-20	LABEL, CAUTION	Etiquette	1	*	1- -300000					
4A	2500-901-015-30	LABEL, CAUTION	Etiquette	1	*	300001-					
5	2500-901-016-20	LABEL, PLUG	Etiquette	1	*	*					
6	2500-901-026-00	LABEL, FIRE	Etiquette	1	*	*					
7	2500-901-027-00	LABEL/CE	Etiquette	1	*	*					
8	2500-901-025-00	LABEL, START	Etiquette	1		1- -300000					
8A	2500-901-025-10	LABEL, START	Etiquette	1		300001- -300390					
8B	2500-901-025-20	LABEL, START	Etiquette	1		300391-					

NUMERICAL INDEX

FC180V-AA00, BA00, CA00

PART CODE Pièces No.	FIG. KEY Réf No.	PART CODE Pièces No.	FIG. KEY Réf No.	PART CODE Pièces No.	FIG. KEY Réf No.
5110-042-117-XX	1 1	5131-072-272-XX	1 9	5230-132-058-XX	8 14
5110-082-097-XX	1 30	5131-162-065-XX	3 7	5241-B04-08X-XX	6 25
5110-082-117-XX	1 2	5131-652-082-XX	11 5	5260-112-297-XX	6 22
5110-092-346-XX	4 1	5131-682-352-XX	7 2	5260-112-306-XX	6 8
5110-122-255-XX	11 2	5131-682-353-XX	7 30	5311-B04-00X-XX	6 14A
5110-122-327-XX	9 1	5131-682-388-XX	7 3	5311-B05-00X-XX	6 14
5110-132-151-XX	9 2	5131-832-504-XX	1 10	5314-401-348-2A	6 23
5110-132-152-XX	9 3	5131-832-505-XX	10 3	5314-401-512-1B	7 34
5110-222-067-XX	1 3	5132-516-052-XX	2 9	5314-401-513-5A	7 35
5110-462-053-XX	9 4	5140-242-183-XX	6 1	5314-401-538-5A	7 32
5110-492-019-XX	1 4	5140-372-127-XX	11 13	5314-G14-00X-XX	6 15
5110-602-139-XX	1 5	5140-902-032-XX	1 11	5315-013-122-AX	2 13
5110-602-141-XX	9 5	5140-902-033-XX	5 7	5316-677-681-2A	10 8
5110-602-142-XX	1 6	5140-902-063-XX	5 1	5317-270-841-9A	6 19
5110-602-143-XX	1 7	5150-032-227-XX	8 26	5390-032-077-XX	7 17
5110-602-144-XX	8 1	5150-032-351-XX	8 3	5391-292-054-XX	7 18
5110-602-145-XX	10 2	5156-R06-80X-XX	9 16	5391-802-796-XX	7 29
5110-602-185-XX	9 6	5160-092-136-XX	8 6	5391-802-895-XX	7 1
5110-602-190-XX	8 4	5160-202-129-XX	8 7	5410-B04-00X-XX	6 16
5110-602-191-XX	8 5	5160-252-166-XX	8 8	5410-B05-00X-XX	6 17
5110-B05-22X-XX	6 24	5160-412-222-XX	8 27	5411-B04-00X-XX	6 17A
5112-B05-22X-XX	6 12	5160-412-223-XX	8 28	5411-B05-00X-XX	9 19
5120-042-101-XX	3 1	5160-412-224-XX	8 9	5420-362-051-XX	7 19
5120-052-089-XX	3 2	5160-412-231-XX	8 10	5460-752-082-XX	11 6
5120-092-062-XX	3 3	5160-412-244-XX	8 11	5482-J90-00X-XX	1 35
5120-162-057-XX	3 4	5160-602-171-XX	9 7	5490-152-291-XX	1 32
5120-322-065-XX	3 5	5160-732-164-XX	8 2	5490-152-338-XX	1 13
5130-012-134-XX	2 1	5160-732-165-XX	6 2	5490-702-491-XX	9 8
5130-021-004-XX	2 5	5161-262-146-XX	1 12	5490-782-064-XX	3 8
5130-086-029-XX	2 3	5161-262-191-XX	8 12	5490-802-166-XX	11 14
5130-252-099-XX	2 4	5161-692-111-XX	7 15	5490-882-423-XX	11 1
5130-292-121-XX	2 2	5161-712-068-XX	7 16	5491-032-127-XX	7 20
5130-312-062-XX	2 6	5161-832-002-XX	8 13	5491-062-446-XX	9 9
5130-702-088-XX	11 3	5172-G06-80X-XX	9 17	5491-092-054-XX	10 4
5130-702-091-XX	3 6	5187-B06-14X-XX	7 27	5491-102-080-XX	7 21
5130-702-092-XX	4 2	5211-192-139-XX	6 18	5491-182-110-XX	3 14
5130-912-129-XX	11 4	5211-302-066-XX	6 3	5491-182-126-XX	3 9
5130-B06-12X-XX	1 24	5211-692-004-XX	6 4	5491-206-074-XX	1 33
5130-B06-30X-XX	7 13	5211-692-066-XX	6 5	5491-206-112-XX	1 14
5130-G06-25X-XX	6 13	5211-712-176-XX	6 20	5510-232-160-XX	10 5
5130-G08-35X-XX	1 25	5211-712-200-XX	6 6	5510-482-072-XX	10 1
5130-G08-45X-XX	1 26	5211-942-249-XX	6 21	5520-052-094-XX	4 3
5130-G08-50X-XX	1 27	5211-942-292-XX	6 7	5520-052-124-XX	4 4
5131-072-255-XX	1 8	5214-B04-20X-XX	7 14	5551-A03-06X-XX	2 8
5131-072-256-XX	1 31	5214-B05-10X-XX	9 18	5551-A06-12X-XX	1 28

PART CODE Pièces No.	FIG. KEY Réf No.	PART CODE Pièces No.	FIG. KEY Réf No.	PART CODE Pièces No.	FIG. KEY Réf No.
5554-A06-00X-XX	1 29	5920-382-077-XX	6 10		
	7 28	5920-491-062-XX	1 19		
5555-A05-16X-XX	1 36	5920-492-199-XX	1 20		
5560-072-118-XX	13 1	5920-492-204-XX	1 21		
5560-312-375-XX	12 1	5920-492-210-XX	1 22		
5560-312-447-XX	12 2	5920-632-242-XX	8 17		
5560-312-470-XX	12 2A	5920-642-094-XX	8 18		
5590-412-083-XX	5 2	5920-662-180-XX	4 6		
5590-512-330-XX	2 7	5920-701-167-XX	6 11		
5590-562-790-XX	1 15	5920-812-234-XX	8 19		
5591-012-095-XX	11 7	5920-932-100-XX	8 20		
5591-062-126-XX	11 8	5921-072-057-XX	13 2		
5592-262-256-XX	7 31	5921-102-093-XX	13 3		
5592-262-291-XX	7 4	5921-432-135-XX	7 8		
5592-312-077-XX	4 5	5921-432-148-XX	7 9		
5670-B30-32X-XX	9 20	5921-442-177-XX	11 11		
5670-D20-15X-XX	4 7	5921-442-266-XX	7 10		
5670-D20-16X-XX	4 8	5921-442-272-XX	11 12		
5920-022-269-XX	7 22	5921-442-315-XX	3 10		
5920-042-135-XX	5 3	5921-442-316-XX	7 11		
5920-092-166-XX	1 16	5921-442-329-XX	7 25		
	9 10	5921-442-332-XX	8 30		
5920-092-308-XX	1 17	5921-442-333-XX	8 21		
	9 11	5921-442-334-XX	8 29		
5920-092-341-XX	3 12	5921-442-335-XX	8 22		
5920-092-347-XX	11 9	5921-442-364-XX	8 23		
5920-092-348-XX	8 15	5921-502-122-XX	2 10		
5920-092-349-XX	8 16	5921-502-152-XX	9 14		
5920-151-170-XX	5 4	5921-502-182-XX	7 12		
5920-151-193-XX	7 23	5921-502-248-XX	3 13		
	9 12	5921-502-263-XX	8 24		
5920-152-051-XX	7 5	5921-502-300-XX	6 12A		
5920-152-253-XX	3 11	5921-902-112-XX	1 23		
5920-221-236-XX	1 34	5921-902-113-XX	10 7		
5920-222-019-XX	7 24	5922-002-029-XX	7 26		
5920-222-102-XX	6 9	5922-002-032-XX	9 15		
5920-222-372-XX	7 6	5922-002-037-XX	5 6		
	7 33	5922-002-058-XX	2 14		
5920-222-69X-XX	1 18	5922-002-061-XX	8 25		
5920-262-272-XX	9 13	5922-002-069-XX	2 12		
5920-262-273-XX	5 5				
5920-332-053-XX	2 11				
5920-332-160-XX	11 10				
5920-372-113-XX	10 6				
5920-372-209-XX	7 7				

NUMERICAL INDEX

FC180V-AB00, BB00

PART CODE Pièces No.	FIG. KEY Réf No.	PART CODE Pièces No.	FIG. KEY Réf No.	PART CODE Pièces No.	FIG. KEY Réf No.
5110-042-117-XX	1 1	5131-652-082-XX	11 5	5391-292-054-XX	7 18
5110-082-117-XX	1 2	5131-682-352-XX	7 2	5391-802-895-XX	7 1
5110-092-346-XX	4 1	5131-682-388-XX	7 3	5391-872-053-XX	12 12
5110-122-255-XX	11 2	5131-682-400-XX	12 2	5410-352-051-XX	12 1
5110-122-327-XX	9 1	5131-832-504-XX	1 10	5410-B04-00X-XX	6 16
5110-132-151-XX	9 2	5131-832-505-XX	10 3	5410-B05-00X-XX	6 17
5110-132-152-XX	9 3	5132-516-052-XX	2 9		12 16
5110-222-067-XX	1 3	5140-242-183-XX	6 1	5411-B04-00X-XX	6 17A
5110-462-053-XX	9 4	5140-372-127-XX	11 13	5411-B05-00X-XX	9 19
5110-492-019-XX	1 4	5140-902-032-XX	1 11	5420-362-051-XX	7 19
5110-602-139-XX	1 5	5140-902-063-XX	5 1	5430-012-056-XX	12 13
5110-602-141-XX	9 5	5150-032-351-XX	8 3	5460-752-091-XX	11 6
5110-602-142-XX	1 6	5156-R06-80X-XX	9 16	5482-L40-00X-XX	12 17
5110-602-143-XX	1 7	5160-092-136-XX	8 6	5490-152-338-XX	1 13
5110-602-144-XX	8 1	5160-202-129-XX	8 7	5490-702-491-XX	9 8
5110-602-145-XX	10 2	5160-252-166-XX	8 8	5490-782-064-XX	3 8
5110-602-185-XX	9 6	5160-412-224-XX	8 9	5490-802-166-XX	11 14
5110-602-190-XX	8 4	5160-412-231-XX	8 10	5490-882-458-XX	11 1
5110-602-191-XX	8 5	5160-412-244-XX	8 11	5491-032-127-XX	7 20
5112-B05-22X-XX	6 12A	5160-602-171-XX	9 7	5491-062-446-XX	9 9
5120-042-101-XX	3 1	5160-732-123-XX	6 18	5491-092-054-XX	10 4
5120-052-089-XX	3 2	5160-732-164-XX	8 2	5491-102-080-XX	7 21
5120-092-062-XX	3 3	5160-732-165-XX	6 2	5491-182-126-XX	3 9
5120-162-057-XX	3 4	5161-262-146-XX	1 12	5491-206-112-XX	1 14
5120-322-065-XX	3 5	5161-262-191-XX	8 12	5510-232-160-XX	10 5
5130-012-134-XX	2 1	5161-692-111-XX	7 15	5510-482-072-XX	10 1
5130-021-004-XX	2 5	5161-712-068-XX	7 16	5520-052-094-XX	4 3
5130-086-029-XX	2 3	5161-712-076-XX	12 11	5520-052-124-XX	4 4
5130-252-099-XX	2 4	5161-832-002-XX	8 13	5550-D20-10X-XX	12 18
5130-292-121-XX	2 2	5172-G06-80X-XX	9 17	5551-A03-06X-XX	2 8
5130-312-062-XX	2 6	5187-B06-14X-XX	7 27	5551-A06-12X-XX	1 28
5130-702-088-XX	11 3	5211-302-066-XX	6 3	5554-A06-00X-XX	1 29
5130-702-091-XX	3 6	5211-692-004-XX	6 4		7 28
5130-702-092-XX	4 2	5211-692-066-XX	6 5	5560-072-118-XX	14 1
5130-912-129-XX	11 4	5211-712-200-XX	6 6	5560-312-375-XX	13 1
5130-B06-12X-XX	1 24	5211-942-292-XX	6 7	5560-312-447-XX	13 2
5130-B06-14X-XX	12 8	5214-B04-20X-XX	7 14	5560-312-470-XX	13 2A
5130-B06-30X-XX	7 13	5214-B05-10X-XX	9 18	5590-412-083-XX	5 2
5130-G06-25X-XX	6 13	5230-132-058-XX	8 14	5590-512-330-XX	2 7
5130-G08-35X-XX	1 25	5260-112-306-XX	6 8	5590-562-790-XX	1 15
5130-G08-45X-XX	1 26	5260-112-323-XX	6 19	5591-012-095-XX	11 7
5130-G08-50X-XX	1 27	5311-B04-00X-XX	6 14	5591-062-131-XX	11 8
5131-072-255-XX	1 8	5311-B05-00X-XX	6 20	5592-262-291-XX	7 4
5131-072-272-XX	1 9	5314-G14-00X-XX	6 15	5592-262-296-XX	12 3
5131-162-065-XX	3 7	5390-032-077-XX	7 17	5592-312-077-XX	4 5

PART CODE Pièces No.	FIG. KEY Réf No.	PART CODE Pièces No.	FIG. KEY Réf No.	PART CODE Pièces No.	FIG. KEY Réf No.
5670-B30-32X-XX	9 20	5921-102-093-XX	14 3		
5670-D20-15X-XX	4 7	5921-432-135-XX	7 8		
5670-D20-16X-XX	4 8	5921-432-148-XX	7 9		
5920-022-269-XX	7 22	5921-432-208-XX	12 6		
5920-042-135-XX	5 3	5921-442-177-XX	11 11		
5920-042-139-XX	5 4	5921-442-266-XX	7 10		
5920-092-166-XX	1 16	5921-442-272-XX	11 12		
	9 10	5921-442-315-XX	3 10		
5920-092-308-XX	1 17	5921-442-316-XX	7 11		
	9 11	5921-442-329-XX	7 25		
5920-092-341-XX	3 12	5921-442-333-XX	8 21		
5920-092-347-XX	11 9	5921-442-335-XX	8 22		
5920-092-348-XX	8 15	5921-442-362-XX	12 15		
5920-092-349-XX	8 16	5921-442-364-XX	8 23		
5920-151-170-XX	5 5	5921-502-122-XX	2 10		
5920-151-193-XX	7 23	5921-502-152-XX	9 14		
	9 12	5921-502-182-XX	7 12		
5920-152-051-XX	7 5		12 10		
	12 4	5921-502-248-XX	3 13		
5920-152-253-XX	3 11	5921-502-263-XX	8 24		
5920-222-019-XX	7 24	5921-502-300-XX	6 12		
5920-222-102-XX	6 9	5921-902-112-XX	1 23		
5920-222-372-XX	7 6	5921-902-113-XX	10 7		
	12 5	5922-002-029-XX	7 26		
5920-222-69X-XX	1 18	5922-002-032-XX	9 15		
5920-262-272-XX	9 13	5922-002-036-XX	12 7		
5920-262-273-XX	5 6	5922-002-037-XX	5 7		
5920-332-053-XX	2 11	5922-002-061-XX	8 25		
5920-332-160-XX	11 10	5922-002-069-XX	2 12		
5920-372-113-XX	10 6				
5920-372-209-XX	7 7				
	12 9				
5920-382-077-XX	6 10				
5920-432-170-XX	12 14				
5920-491-062-XX	1 19				
5920-492-199-XX	1 20				
5920-492-204-XX	1 21				
5920-492-210-XX	1 22				
5920-632-242-XX	8 17				
5920-642-094-XX	8 18				
5920-662-180-XX	4 6				
5920-701-167-XX	6 11				
5920-812-234-XX	8 19				
5920-932-100-XX	8 20				
5921-072-057-XX	14 2				

NUMERICAL INDEX

2500-098-200-10

PART CODE Pièces No.	FIG. KEY Réf No.	PART CODE Pièces No.	FIG. KEY Réf No.	PART CODE Pièces No.	FIG. KEY Réf No.
1105-712-004-00	9 8	2500-265-008-20	2 6	2500-312-008-10	4 2
1328-601-004-00	3 2	2500-265-009-10	2 3	2500-312-200-00	4 6
1338-301-005-00	9 9	2500-265-013-00	2 7	2500-326-002-00	8 17
1365-224-002-00	7 14	2500-265-014-00	2 8A	2500-326-009-00	8 24
	7 16		24 5	2500-326-009-10	8 24A
1373-121-001-00	8 19	2500-302-051-00	5 7	2500-326-014-00	8 10
	9 18	2500-310-001-00	6 7		9 5
1376-402-003-00	21 4	2500-310-001-10	6 7A	2500-326-017-00	8 8
	21 7	2500-310-003-00	6 10		8 11
1425-621-004-00	16 3	2500-310-005-10	6 12		13 7
1427-601-003-00	17 3	2500-310-006-00	6 11		14 9
	14 11		8 18	2500-326-021-00	8 6
	20 4	2500-310-007-00	6 17	2500-352-200-10	5 1
1527-604-002-00	14 16	2500-310-008-00	6 3	2500-352-202-00	5 3
2500-151-001-00	1 1	2500-310-009-10	6 5	2500-360-002-00	6 1
2500-210-001-00	1 3		6 8	2500-360-002-10	6 1A
	2 1	2500-310-012-00	6 13	2500-360-004-10	6 2
2500-210-002-00	1 12	2500-310-200-00	6 16	2500-361-006-10	7 17
2500-210-004-20	1 11	2500-311-001-00	7 1	2500-361-006-20	7 17A
2500-210-005-00	1 13	2500-311-001-10	7 1A	2500-361-011-00	7 23
	6 14	2500-311-002-00	7 12	2500-361-011-10	7 23A
	6 18	2500-311-002-10	7 12A	2500-361-021-00	7 4
	8 25	2500-311-003-00	7 11	2500-361-023-00	7 5A
	11 5	2500-311-004-00	7 24	2500-361-024-00	7 7A
	12 5	2500-311-005-10	7 9	2500-376-001-20	8 13
2500-210-006-10	12 7	2500-311-005-20	7 9A		9 12
	12 11	2500-311-007-00	7 18	2500-376-004-00	8 15
	1 14	2500-311-008-00	7 21		9 14
2500-210-008-00	1 15	2500-311-009-10	7 22	2500-376-006-20	8 16
	14 18	2500-311-012-00	4 8		9 15
2500-210-016-00	1 9		7 25	2500-376-008-20	8 2
2500-210-017-00	1 2		8 5		8 4
2500-210-202-00	2 8	2500-311-013-00	7 10	2500-376-012-10	8 7
2500-210-302-00	1 6	2500-311-015-10	7 8	2500-376-013-20	8 9
2500-210-303-00	1 7	2500-311-016-00	7 19	2500-376-230-00	8 1
2500-215-001-00	2 2	2500-311-017-00	7 20	2500-376-240-00	8 3
2500-215-002-00	24 4	2500-311-018-00	7 13	2500-386-001-00	9 10
2500-215-003-00	1 10	2500-311-019-00	7 13A	2500-386-002-30	9 6
2500-260-301-10	1 5	2500-311-021-00	7 5	2500-386-004-40	9 4
2500-260-310-00	1 4	2500-311-022-00	7 6	2500-386-005-10	9 7
2500-260-310-10	1 4A	2500-311-200-00	7 3	2500-386-007-10	9 3
2500-265-001-30	2 4	2500-312-002-00	4 1	2500-386-012-10	9 16
	3 1	2500-312-003-00	4 3	2500-386-200-30	9 1
2500-265-003-00	2 9	2500-312-004-10	4 4	2500-386-210-30	9 2
2500-265-007-30	2 5	2500-312-005-10	4 5	2500-401-002-00	12 3

PART CODE Pièces No.	FIG. KEY Réf No.	PART CODE Pièces No.	FIG. KEY Réf No.	PART CODE Pièces No.	FIG. KEY Réf No.
2500-401-003-00	12 4	2500-510-240-00	20 9	2500-901-026-00	23 6
2500-401-006-00	9 17	2500-510-240-10	14 8	2500-901-027-00	23 7
	10 2		20 9A	2500-930-001-00	26 1
	12 8	2500-510-410-00	20 11	2500-930-002-00	26 2
2500-401-009-00	10 1	2500-510-410-10	20 11A	2500-931-001-00	24 3
2500-401-011-10	12 1	2500-515-001-00	14 17	2500-931-210-00	24 1
2500-401-014-00	12 12	2500-515-230-10	14 2	2500-932-210-00	24 7
2500-420-001-00	11 1	2500-520-002-10	21 2	2500-951-002-00	25 1
2500-420-003-00	11 2	2500-520-003-10	21 3	2500-951-004-00	25 2
2500-420-004-00	11 3	2500-551-019-00	15 5	2500-951-005-10	25 4
2500-420-005-00	11 4		19 2	2500-951-006-00	25 3
2500-451-007-10	12 9	2500-551-210-20	15 1	2500-990-011-00	26 5
2500-451-007-20	12 9A	2500-551-210-30	15 1A	2500-990-011-10	26 5A
2500-451-200-30	12 2	2500-552-002-20	16 7	2500-991-001-20	26 5B
2500-451-200-40	12 2A	2500-552-220-20	16 1	2503-302-201-10	5 2
2500-451-200-60	12 2B		17 1	2503-302-203-10	5 4
2500-451-210-00	12 6	2500-553-001-50	18 7	2503-302-204-10	5 5
2500-501-002-10	14 19	2500-553-002-00	18 12	2503-510-003-20	20 2
	15 2	2500-553-003-00	18 1	2503-510-004-20	14 10
2500-501-003-00	16 2	2500-555-210-10	19 1		20 3
2500-501-003-10	16 2A	2500-555-210-20	19 1A	2706-301-020-00	8 22
	17 2	2500-560-230-20	14 2A		9 21
2500-502-250-00	17 7		20 1	3650-440-014-00	4 7
2500-510-001-10	13 8	2500-570-001-00	21 1	3740-162-005-00	12 10
2500-510-002-00	13 9	2500-570-006-00	21 5		13 6
	14 14	2500-570-007-00	21 6	3747-342-002-00	8 23
2500-510-003-00	20 12	2500-607-001-00	22 2		9 22
2500-510-003-10	20 12A	2500-607-200-00	22 1	3768-172-008-00	6 15
2500-510-005-00	13 2	2500-607-300-00	22 3	J910-000-200-00	23 1
	14 3	2500-901-007-00	25 5	V200-260-501-60	7 6A
2500-510-006-00	5 7A	2500-901-007-10	25 5A	V200-260-601-00	14 20
	7 2	2500-901-008-00	25 6	V201-260-802-00	18 6
	13 3	2500-901-014-20	23 3	V201-260-805-00	18 8
	14 4	2500-901-014-30	23 3A	V201-260-805-50	18 8A
2500-510-011-00	13 1	2500-901-015-20	23 4	V203-361-002-00	3 4
	14 1	2500-901-015-30	23 4A	V203-361-003-00	24 2
2500-510-013-00	14 5	2500-901-016-20	23 5	V210-160-601-00	15 3
	20 8	2500-901-017-00	25 7	V210-360-601-00	15 3A
2500-510-015-00	20 13A	2500-901-017-20	25 7A	V210-360-601-60	8 12
2500-510-051-10	13 5	2500-901-018-00	23 2	V301-260-005-00	7 7
	14 7	2500-901-018-10	23 2A	V304-260-008-00	8 21
	14 23	2500-901-018-30	23 2B		9 11
	20 10	2500-901-025-00	23 8		9 20
2500-510-220-00	13 4	2500-901-025-10	23 8A		18 11
	14 6	2500-901-025-20	23 8B	V304-260-010-00	24 6

2500-098-200-10

PART CODE Pièces No.	FIG. KEY Réf No.	PART CODE Pièces No.	FIG. KEY Réf No.	PART CODE Pièces No.	FIG. KEY Réf No.
V305-260-008-00 V340-120-006-00 V341-120-008-00	18 5 14 22 15 4 14 13 15 8				
	16 6 17 6 18 2 19 5 20 6				
V401-160-008-00	8 20 9 19 14 12 15 7 16 5				
	17 5 18 4 18 10 18 13 19 4				
V401-160-010-00 V411-260-006-00 V411-260-008-00	20 5 3 3 14 21 1 8 15 6				
	16 4 17 4 18 3 18 9 19 3				
V600-150-600-20 V653-410-172-00 V704-140-012-00 V704-140-014-00	8 14 9 13 6 2A 4 9 14 15				
V704-140-020-00 V710-140-007-00 V744-112-220-70	20 7 5 6 7 15 20 13 6 4				
V780-140-000-2B V920-551-001-20 V920-551-201-40	6 9 6 6 26 4 26 3				

ALPHABETICAL INDEX

FC180V-AA00, BA00, CA00

DESCRIPTION	FIG. KEY	DESCRIPTION	FIG. KEY
O RING	9 20	CASE-ROCKER	1 3
O RING	4 7	CHAMBER-FLOAT	8 7
O RING	4 8	CIRCLIP, TYPE E	1 35
ARM-GOVERNOR	7 20	CLAMP	10 8
ARM-PIVOT	7 17	CLAMP	10 6
ARM-ROCKER	3 4	CLAMP	7 7
BOLT	7 22	CRANKCASE-COMP	1 33
BOLT	9 14	CRANKCASE-COMP	1 14
BOLT	3 13	CRANKSHAFT-COMP	2 6
BOLT	8 24	ELEMENT-AIR FILTER	9 2
BOLT-4X20	6 12A	ELEMENT-AIR-FILTER	9 3
BOLT-5X18	7 12	ELEMENT-BREATHER	10 4
BOLT-CONNECTING ROD	2 10	FAN	5 2
BOLT-FLANGED	6 24	FILLER	4 5
BOLT-FLANGED	1 24	FLOAT-ASSY	8 13
BOLT-FLANGED	7 13	FLYWHEEL-COMP	6 21
BOLT-FLANGED	6 13	FLYWHEEL-COMP	6 7
BOLT-FLANGED	1 25	GOVERNOR-ASSY	7 21
BOLT-FLANGED	1 26	GASKET	9 5
BOLT-FLANGED	1 27	GASKET	1 7
BOLT-STUD	9 17	GASKET	10 2
BOLT-UPSET	6 12	GASKET	8 4
BOLT-UPSET-WSP	7 27	GASKET	8 5
BOLT-WP	9 16	GASKET-OIL GAUGE	4 1
BRACKET	9 4	GASKET-CARBURETOR	8 1
BRACKET	1 4	GASKET-CRANKCASE	1 6
COIL-ASSY-IGNITION	6 20	GASKET-HEAD	1 1
COIL-ASSY-IGNITION	6 6	GASKET-MUFFLER	9 6
COLLAR	7 9	GASKET-ROCKER CASE	1 5
COLLAR-6X13X2.3	7 8	GAUGE	4 4
COVER	6 1	GAUGE-OIL	4 3
COVER	1 11	GEAR-HERICAL	1 15
COVER	5 7	GEAR-SPUR	2 7
COVER	5 1	GRIP-RECOIL STARTER	11 6
COVER-CRANKCASE	1 32	GUIDE	3 6
COVER-CRANKCASE	1 13	GUIDE	4 2
COVER-MUFFLER	9 9	GUIDE-PAWL	11 3
CAMSHAFT-COMP	3 14	HOLDER-RECOIL	11 4
CAMSHAFT-COMP	3 9	HEAD-COMP-CYLINDER	1 30
CAP-AIR FILTER	9 1	HEAD-COMP-CYLINDER	1 2
CAP-ASSY-TANK	10 1	IGNITER	6 18
CAP-GRIP	11 2	INSULATOR	8 2
CAP-SPARK PLUG	6 3	INSULATOR	6 2
CARBURETOR-ASSY	8 26	JET-MAIN 92	8 17
CARBURETOR-ASSY	8 3	JET-PILOT 44	8 18

FC180V-AA00, BA00, CA00

DESCRIPTION	FIG. KEY	DESCRIPTION	FIG. KEY
KEY	6 10	RING-SET-PISTONL	2 4
LABEL-MANUAL	12 1	RING-SNAP	2 13
LABEL-MANUAL	12 2	RING-SNAP	2 11
LABEL-MANUAL	12 2A	RING-SNAP	11 10
LEVER	7 2	SCREEN	11 13
LEVER	7 30	SCREW	1 17
LEVER	7 3	SCREW	9 11
LINK	7 16	SCREW	3 12
LINK-CHOKE	7 15	SCREW	11 9
MUFFLER-COMP	9 8	SCREW	8 15
NEEDLE-JET	8 6	SCREW	8 16
NUT	7 32	SCREW, PAN-WP	6 25
NUT	5 4	SCREW-5X8	1 16
NUT	7 23	SCREW-5X8	9 10
NUT	9 12	SCREW-ASSY	8 14
NUT	7 5	SCREW-PAN	7 14
NUT	3 11	SCREW-PAN	9 18
NUT-HEX	6 14A	SEAL	8 20
NUT-HEX	6 14	SEAL-OIL	1 19
NUT-HEX-FINE	6 15	SEAL-OIL	1 20
PANEL-ASSY-CONTROL	7 29	SEAL-OIL	1 21
PANEL-ASSY-CONTROL	7 1	SEAL-OIL	1 22
PANEL-CONTROL	7 31	SHAFT	1 8
PANEL-CONTROL	7 4	SHAFT	1 31
PAWL-RECOIL STARTER	11 5	SHAFT	1 9
PIN-DOWEL	2 8	SHAFT-CARBURETOR	8 27
PIN-DOWEL	1 28	SHAFT-CARBURETOR	8 28
PIN-PISTON	2 5	SHAFT-CARBURETOR	8 9
PIN-SNAP	1 29	SHAFT-CARBURETOR	8 10
PIN-SNAP	7 28	SHAFT-CARBURETOR	8 11
PIN-SPRING	1 36	SLEEVE	7 34
PIPE-INTAKE	9 7	SLEEVE	7 19
PISTON-ENGINE	2 1	SPACER-6. 2X7. 8X17	5 5
PISTON-ENGINE-0. 50	2 2	SPACER-6. 2X7. 8X8	9 13
PLATE	1 10	SPRING	8 19
PLATE	10 3	SPRING	7 10
PLUG	4 6	SPRING	11 12
PLUG-SPARK-BP5ES	6 11	SPRING	3 10
PULLEY-STARTING	11 14	SPRING	7 11
ROD-ASSY-CONNECTING	2 9	SPRING	7 25
ROD-PUSH	3 7	SPRING	8 30
ROPE-3. 8X1650	11 8	SPRING	8 21
REEL-RECOIL STARTER	11 7	SPRING	8 29
RETAINER-VALVE	3 3	SPRING	8 22
RING-SET-PISTON	2 3	SPRING	8 23

DESCRIPTION	FIG. KEY	DESCRIPTION	FIG. KEY
SPRING-ENGINEVALVE	3 8		
SPRING-GOVERNOR	7 18		
SPRING-RETURN	11 11		
STARTER-RECOIL	11 1		
STUD	5 3		
TOOL-DRIVER	13 2		
TOOL-WRENCH-19X21	13 3		
TOOLKIT	13 1		
TAP-ASSY	10 5		
TAPPET	3 5		
TERMINAL	6 4		
TERMINAL	6 5		
TERMINAL	6 19		
TUBE-12X16X46	1 23		
TUBE-5X10X223	10 7		
VALVE	1 12		
VALVE-CHOKE	8 12		
VALVE-EXHAUST	3 2		
VALVE-INTAKE	3 1		
VALVE-THROTTLE	8 8		
W-PLAIN-S	6 16		
W-PLAIN-S	6 17		
WASHER	6 23		
WASHER	7 35		
WASHER	1 34		
WASHER	7 24		
WASHER	6 9		
WASHER	1 18		
WASHER	2 12		
WASHER-6.5X11.5X2.0	7 26		
WASHER-6.5X18X2.0	5 6		
WASHER-6X19X1.2	7 6		
WASHER-6X19X1.2	7 33		
WASHER-7X21X2.3	9 15		
WASHER-9.8X5.5X1.0	8 25		
WASHER-PLAIN	6 17A		
WASHER-PLAIN	9 19		
WASHER/28X40X0.5	2 14		
WIRE-LEAD	6 22		
WIRE-LEAD	6 8		

ALPHABETICAL INDEX

FC180V-AB00, BB00

DESCRIPTION	FIG. KEY	DESCRIPTION	FIG. KEY
O RING	9 20	CIRCLIP-TYPE-E	12 17
O RING	4 7	CLAMP	10 6
O RING	4 8	CLAMP	7 7
ARM-GOVERNOR	7 20	CLAMP	12 9
ARM-PIVOT	7 17	CRANKCASE-COMP	1 14
ARM-ROCKER	3 4	CRANKSHAFT-COMP	2 6
BOLT	7 22	ELEMENT-AIR FILTER	9 2
BOLT	9 14	ELEMENT-AIR FILTER	9 3
BOLT	3 13	ELEMENT-BREATHER	10 4
BOLT	8 24	FAN	5 2
BOLT-4X20	6 12	FILLER	4 5
BOLT-5X18	7 12	FLORT-ASSY	8 13
BOLT-5X18	12 10	FLYWHEEL-COMP	6 7
BOLT-CONNECTING ROD	2 10	GOVERNOR-ASSY	7 21
BOLT-FLANGED	1 24	GASKET	9 5
BOLT-FLANGED	12 8	GASKET	1 7
BOLT-FLANGED	7 13	GASKET	10 2
BOLT-FLANGED	6 13	GASKET	8 4
BOLT-FLANGED	1 25	GASKET	8 5
BOLT-FLANGED	1 26	GASKET-OIL GAUGE	4 1
BOLT-FLANGED	1 27	GASKET-CARBURETOR	8 1
BOLT-STUD	9 17	GASKET-CRANKCASE	1 6
BOLT-UPSET	6 12A	GASKET-HEAD	1 1
BOLT-UPSET-WSP	7 27	GASKET-MUFFLER	9 6
BOLT-WP	9 16	GASKET-ROCKER CASE	1 5
BAND-BRAKE	12 12	GAUGE	4 4
BRACKET	9 4	GAUGE-OIL	4 3
BRACKET	1 4	GEAR-HERICAL	1 15
COIL-ASSY-IGNITION	6 6	GEAR-SPUR	2 7
COLLAR	7 9	GRIP-RECOIL STARTER	11 6
COLLAR	12 6	GUIDE	3 6
COLLAR-6X13X2.3	7 8	GUIDE	4 2
COVER	6 1	GUIDE-PAWL	11 3
COVER	1 11	HOLDER-RECOIL	11 4
COVER	5 1	HEAD-COMP-CYLINDER	1 2
COVER-CRANKCASE	1 13	INSULATOR	6 18
COVER-MUFFLER	9 9	INSULATOR	8 2
CAMSHAFT-COMP	3 9	INSULATOR	6 2
CAP-AIR FILTER	9 1	JET-MAIN 92	8 17
CAP-ASSY-TANK	10 1	JET-PILOT 44	8 18
CAP-GRIP	11 2	KEY	6 10
CAP-SPARK PLUG	6 3	LABEL-MANUAL	13 1
CARBURETOR-ASSY	8 3	LABEL-MANUAL	13 2
CASE-ROCKER	1 3	LABEL-MANUAL	13 2A
CHAMBER-FLOAT	8 7	LEVER	7 2

DESCRIPTION	FIG. KEY	DESCRIPTION	FIG. KEY
LEVER	7 3	RING-SNAP	11 10
LEVER	12 2	SCREEN	11 13
LEVER-BRAKE	12 13	SCREW	1 17
LINK	7 16	SCREW	9 11
LINK	12 11	SCREW	3 12
LINK-CHOKE	7 15	SCREW	11 9
MUFFLER-COMP	9 8	SCREW	8 15
NEEDLE-JET	8 6	SCREW	8 16
NUT	5 5	SCREW-5X8	1 16
NUT	7 23	SCREW-5X8	9 10
NUT	9 12	SCREW-ASSY	8 14
NUT	7 5	SCREW-PAN	7 14
NUT	12 4	SCREW-PAN	9 18
NUT	3 11	SEAL	8 20
NUT-HEX	6 14	SEAL-OIL	1 19
NUT-HEX	6 20	SEAL-OIL	1 20
NUT-HEX-FINE	6 15	SEAL-OIL	1 21
PANEL-ASSY BRAKE	12 1	SEAL-OIL	1 22
PANEL-ASSY-CONTROL	7 1	SHAFT	1 8
PANEL-CONTROL	7 4	SHAFT	1 9
PANEL-CONTROL	12 3	SHAFT-CARBURETOR	8 9
PAWL-RECOIL STARTER	11 5	SHAFT-CARBURETOR	8 10
PIN	12 14	SHAFT-CARBURETOR	8 11
PIN-COTTER	12 18	SLEEVE	7 19
PIN-DOWEL	2 8	SPACER-6. 2X7. 8X17	5 6
PIN-DOWEL	1 28	SPACER-6. 2X7. 8X8	9 13
PIN-PISTON	2 5	SPRING	8 19
PIN-SNAP	1 29	SPRING	7 10
PIN-SNAP	7 28	SPRING	11 12
PIPE-INTAKE	9 7	SPRING	3 10
PISTON-ENGINE	2 1	SPRING	7 11
PISTON-ENGINE L-0.50	2 2	SPRING	7 25
PLATE	1 10	SPRING	8 21
PLATE	10 3	SPRING	8 22
PLUG	4 6	SPRING	12 15
PLUG-SPARK-BP5ES	6 11	SPRING	8 23
PULLEY-STARTING	11 14	SPRING-ENGINEVALVE	3 8
ROD-ASSY-CONNECTING	2 9	SPRING-GOVERNOR	7 18
ROD-PUSH	3 7	SPRING-RETURN	11 11
ROPE-3. 8X2450	11 8	STARTER-RECOIL	11 1
REEL-RECOIL STARTER	11 7	STUD	5 3
RETAINER-VALVE	3 3	STUD	5 4
RING-SET-PISTON	2 3	TOOL-DRIVER	14 2
RING-SET-PISTON L-0.5	2 4	TOOL-WRENCH-19X21	14 3
RING-SNAP	2 11	TOOLKIT	14 1

FC180V-AB00, BB00

DESCRIPTION	FIG. KEY	DESCRIPTION	FIG. KEY
TAP-ASSY	10 5		
TAPPET	3 5		
TERMINAL	6 4		
TERMINAL	6 5		
TUBE-12X16X46	1 23		
TUBE-5X10X223	10 7		
VALVE	1 12		
VALVE-CHOKE	8 12		
VALVE-EXHAUST	3 2		
VALVE-INTAKE	3 1		
VALVE-THROTTLE	8 8		
W-PLAIN-S	6 16		
W-PLAIN-S	6 17		
W-PLAIN-S	12 16		
WASHER	7 24		
WASHER	6 9		
WASHER	1 18		
WASHER	12 7		
WASHER	2 12		
WASHER-6. 5X11. 5X2. 0	7 26		
WASHER-6. 5X18X2. 0	5 7		
WASHER-6X19X1. 2	7 6		
WASHER-6X19X1. 2	12 5		
WASHER-7X21X2. 3	9 15		
WASHER-9. 8X5. 5X1. 0	8 25		
WASHER-PLAIN	6 17A		
WASHER-PLAIN	9 19		
WIRE-LEAD	6 8		
WIRE-LEAD	6 19		

ALPHABETICAL INDEX

CHASSIS

DESCRIPTION	FIG. KEY	DESCRIPTION	FIG. KEY
ARM, CLUTCH	7 5	BPLT, TAPPING/06X16	6 18
ARM, CLUTCH	7 4	BRACKET, F WHEEL COMP	9 1
BAND, WIRE/140	21 4	BRACKET, F WHEEL COMP	9 2
BAND, WIRE/140	21 7	BRACKET, HANDLE COMP	16 1
BAR, WRENCH	26 2	BRACKET, HANDLE COMP	17 1
BBC ASSY	1 4	BRACKET, R WHEEL ASSY	8 1
BBC(5. 5PS) ASSY	1 4A	BRACKET, R WHEEL ASSY	8 3
BEARING, NEEDLL	6 2	BUSH/12X14X20	4 7
BEARING, NEEDLL	6 2A	BUSH/12X15X20	8 2
BOLT, FLANGE/M10X30	1 1	BUSH/12X15X20	8 4
BOLT, MOUNTING	1 5	BUSH/14X20X11	14 5
BOLT, P/M6X10	15 3	BUSH/14X20X11	20 8
BOLT, RAPPING, PT1/8	6 6	CABLE, BBC	1 11
BOLT, SP/M6X10	15 3A	CABLE, BRAKE	21 5
BOLT, SP/M6X16	8 12	CABLE, CHANGE	21 2
BOLT, TAOOING/06X25	6 11	CABLE, CLUTCH	21 3
BOLT, TAPPING/06X12	9 17	CABLE, THROTTLE	21 1
BOLT, TAPPING/06X12	10 2	CAM, DRIVE CLUTCH	7 11
BOLT, TAPPING/06X12	12 8	CAM, RACHET	4 4
BOLT, TAPPING/06X16	1 13	CAM, SHIFT	7 20
BOLT, TAPPING/06X16	6 14	CAP	8 6
BOLT, TAPPING/06X16	8 25	CAP, WHEEL	8 22
BOLT, TAPPING/06X16	11 5	CAP, WHEEL	9 21
BOLT, TAPPING/06X16	12 5	CASE, MISSION/LH	6 7
BOLT, TAPPING/06X16	12 7	CASE, MISSION/LH	6 7A
BOLT, TAPPING/06X16	12 11	CASE, MISSION/RH	6 1
BOLT, TAPPING/06X25	8 18	CASE, MISSION/RH	6 1A
BOLT, TAPPING/06X35	6 13	CLAMP, HARNESS	16 3
BOLT, TAPPING/08X20	18 12	CLAMP, HARNESS	17 3
BOLT, UNF3/8X38	1 10	CLAMP/7	6 15
BOLT, UNF3/8X51	2 9	CLIP, TRIM/8	14 16
BOLT/M05X20	7 6	CLOTH, COLLECTOR COMP	22 3
BOLT/M05X20	7 6A	COLLAR/15X20X08	14 10
BOLT/M08X40	16 2	COLLAR/15X20X08	20 3
BOLT/M08X45	9 6	COLLAR/16X22X22	8 15
BOLT/M10X20	3 4	COLLAR/16X22X22	9 14
BOLT/M10X30	24 2	COVER, COLLECTOR	22 2
BOLT/M10X55	24 3	COVER, CONTROL	13 8
BOLT/M6X10	14 20	COVER, DECK/LH	12 3
BOLT/M8X20	18 6	COVER, DECK/RH	12 4
BOLT/M8X40	16 2A	COVER, DESCAHARGE	11 1
BOLT/M8X40	17 2	COVER, FAN/N	10 1
BOLT/M8X50	18 8	COVER, MISSION	12 9
BOLT/M8X55	18 8A	COVER, NISSION	12 9A
BOSS	2 2	COVER, STONE GUARD	12 12

CHASSIS

DESCRIPTION	FIG. KEY	DESCRIPTION	FIG. KEY
COVER, UNDER COMP	12 6	LABEL, NOISE/100	25 6
COVER, WHEEL	8 7	LABEL, PLUG	23 5
COVER, WHEEL, FRONT	9 16	LABEL, START	23 8
DECK	12 1	LABEL, START	23 8A
FRAME, COLLECTOR COMP	22 1	LABEL, START	23 8B
GASKET	6 10	LABEL, TRAVEL	25 7
GEAR, BEVEL/14	7 1	LABEL, TRAVEL	25 7A
GEAR, BEVEL/14	7 1A	LABEL/BBC	23 2
GEAR, BEVEL/55	7 12	LABEL/BBC	23 2A
GEAR, BEVEL/55	7 12A	LABEL/BBC	23 2B
GEAR, OUTPUT	7 23	LABEL/CE	23 7
GEAR, OUTPUT	7 23A	LEVER COMP	14 2A
GEAR, SPUR/13 ASSY	4 6	LEVER COMP	20 1
GEAR, SPUR/26	7 18	LEVER, AXLE	13 1
GEAR, SPUR/31	7 17	LEVER, AXLE	14 1
GEAR, SPUR/31	7 17A	LEVER, BBC	20 9
GEAR, SPUR/42	8 17	LEVER, BBC	14 8
GRIP	8 10	LEVER, BBC	20 9A
GRIP	9 5	LEVER, CHANGE COMP	13 4
GUARD, DECK COMP	12 2A	LEVER, CHANGE COMP	14 6
GUARD, DECK COMP	12 2B	LEVER, LOCK COMP	20 11
GUARD, DESK COMP	12 2	LEVER, LOCK COMP	20 11A
HANDLE, B/E COMP	19 1	LEVER, PIPE/E COMP	14 2
HANDLE, B/E COMP	19 1A	LEVER, SPRING, FRONT	9 4
HANDLE/A	16 7	LEVER, SPRING, REAR	8 9
HANDLE/A COMP	17 7	LINING/26X56X3	2 3
HANDLE/B COMP	15 1	MANUAL/4	26 5B
HANDLE/B COMP	15 1A	MANUAL/4/PRO	26 5
HOLDER	6 17	MANUAL/4/PRO	26 5A
HOLDER, BRACKET, WHEEL	8 24	NUT	24 6
HOLDER, BRACKET, WHEEL	8 24A	NUT, CAP/M6	14 22
HOLDER, RACHET	4 3	NUT, CAP/M6	15 4
JOINT ASSY	5 1	NUT, CAP/M8	15 8
JOINT/A	5 2	NUT, CAP/M8	16 6
JOINT/B	5 4	NUT, CAP/M8	18 2
KEY, WOODRUFF04X06X16	1 3	NUT, CAP/M8	19 5
KEY, WOODRUFF04X06X16	2 1	NUT, CAP/M8	20 6
LABEL, CAUTION	23 4	NUT, FLANGE/M06	8 8
LABEL, CAUTION	23 4A	NUT, FLANGE/M06	8 11
LABEL, CONTROL	25 5	NUT, FLANGE/M06	13 7
LABEL, CONTROL	25 5A	NUT, FLANGE/M06	14 9
LABEL, DANBER	23 3	NUT/M08	9 10
LABEL, DANGER	23 3A	NUT/M5	7 7
LABEL, FIRE	23 6	NUT/M8	8 21
LABEL, MODEL ASSY	23 1	NUT/M8	9 11

DESCRIPTION	FIG. KEY	DESCRIPTION	FIG. KEY
NUT/M8	9 20	S. W/M8	15 7
NUT/M8	18 11	S. W/M8	16 5
NUT/M8	18 5	S. W/M8	17 5
NUT/M8	14 13	S. W/M8	18 4
NUT/M8	17 6	S. W/M8	18 10
ORNAMENT, ENGINE/LH	25 1	S. W/M8	18 13
ORNAMENT, ENGINE/RH	25 2	S. W/M8	19 4
ORNAMENT, ISEKI	25 3	S. W/M8	20 5
ORNAMENT/SW621	25 4	SCREW, TAPPING/05X16	13 9
PIN, /05X22	7 24	SCREW, TAPPING/05X16	14 14
PIN, M08X38	15 5	SEAL, OIL	6 3
PIN, STRAIGHT/04X18/A	4 2	SEAL, OIL	6 5
PIN/04X18	5 5	SEAL, OIL	6 8
PIN/08X14	1 15	SEAL, OIL	6 4
PIN/08X14	14 18	SEAL, OIL	6 9
PIN/08X334	11 3	SEAL12X05	4 1
PIN/08X49	7 21	SHAFT, INPUT	7 9
PIN/14X70	20 2	SHAFT, INPUT	7 9A
PIN/M08X38	19 2	SHAFT, SPLINE	5 3
PLATE	6 12	SHAFT, WHEEL	7 22
PLATE, BAR, HANDLE	18 7	SHIFTER COMP	6 16
PLATE, CAP	9 7	SHIFTER COMP	7 3
PLATE, HOOK	1 2	SHIM/0. 3/11X24	2 6
PLATE, I/13X22	7 5A	SHIM/0. 3X20X30	7 13A
PLATE, I/13X22	7 7A	SHIM/0. 5	7 13
PLATE, I/16X28	11 4	SPACER	2 5
PLATE, SPRING	14 19	SPANNER	26 4
PLATE, SPRING	15 2	SPANNER	26 3
PLATE, WIRE	1 12	SPECIAL, TOOL, ENGINE	24 7
PLATE/520	2 4	SPECIAL, TOOL/BCCOMP	24 1
PLATE/520	3 1	SPRING, DISK/10	13 2
R. B. B	8 14	SPRING, DISK/10	14 3
R. B. B	9 13	SPRING, HC016	1 6
RING, SNAP/12	4 9	SPRING, PLATE	2 7
RING, SNAP/14	14 15	SPRING, RACHET	4 5
RING, SNAP/14	20 7	SPRING/HCO39	7 8
RING, SNAP/20	5 6	SPRING/HCO48	7 19
RING, SNAP/20	7 15	SPRING/HE077	13 5
RING, SNAP/E	20 13A	SPRING/HE077	14 7
RING, SNAP/E7	20 13	SPRING/HE077	14 23
S. W	2 8	SPRING/HE077	20 10
S. W	8 20	SPRING/HE108	1 9
S. W	9 19	SPRING/HE145	1 14
S. W	14 12	SPRING/HE145	14 17
S. W	3 3	SPRING/HT010	20 12

CHASSIS

DESCRIPTION	FIG. KEY	DESCRIPTION	FIG. KEY
SPRING/HT010	20 12A		
SPRING/HT012	11 2		
SPRING/HT07	21 6		
STAY, BAR, HANDLE	18 1		
TIAR/9X2. 5	9 15		
TIER/9X2. 5	8 16		
WASHER	3 2		
WASHER	9 9		
WASHER	7 14		
WASHER	7 16		
WASHER	12 10		
WASHER	13 6		
WASHER	8 23		
WASHER	9 22		
WASHER, PL/M8	1 8		
WASHER, PL/M8	15 6		
WASHER, PL/M8	16 4		
WASHER, PL/M8	17 4		
WASHER, PL/M8	18 3		
WASHER, PL/M8	19 3		
WASHER/08X18X2	9 8		
WASHER/10X37X06	2 8A		
WASHER/10X37X06	24 5		
WASHER/10X55X05	24 4		
WASHER/11X20X01	5 7A		
WASHER/11X20X01	7 2		
WASHER/11X20X01	13 3		
WASHER/11X20X01	14 4		
WASHER/11X25X01	5 7		
WASHER/11X45X03	1 7		
WASHER/12X21X01	4 8		
WASHER/12X21X01	7 25		
WASHER/12X21X01	8 5		
WASHER/13X46X01	9 3		
WASHER/15X24X2	14 11		
WASHER/15X24X2	20 4		
WASHER/17X24X01	7 10		
WASHER/9X22X2	8 19		
WASHER/9X22X2	9 18		
WASHER/M6	14 21		
WASHER/M8	18 9		
WHEEL	8 13		
WHEEL	9 12		
WRENCH, PLUG	26 1		