

Ta

SF333 engine

| | |
|-----------------------------|---------|
| CYLINDER HEAD | Fig. 1 |
| CYLINDER HEAD COVER | Fig. 2 |
| INLET MANIFOLD | Fig. 3 |
| EXHAUST MANIFOLD | Fig. 4 |
| CYLINDER BLOCK | Fig. 5 |
| BEARING/UNDER SIZE (OPTION) | Fig. 6 |
| OIL PAN | Fig. 7 |
| REAR PLATE | Fig. 8 |
| TIMING GEAR CASE | Fig. 9 |
| HANGER | Fig. 10 |
| VALVE | Fig. 11 |
| CAM SHAFT | Fig. 12 |
| PISTON | Fig. 13 |
| PISTON/OVER SIZE (OPTION) | Fig. 14 |
| CRANK SHAFT | Fig. 15 |
| OIL PUMP | Fig. 16 |
| WATER PUMP | Fig. 17 |
| COOLING FAN | Fig. 18 |
| INJECTION NOZZLE | Fig. 19 |
| INJECTION PUMP | Fig. 20 |
| FUEL PIPE | Fig. 21 |
| ADAPTER | Fig. 22 |
| ELECTRIC (1) | Fig. 23 |
| ELECTRIC (2) | Fig. 24 |
| LABEL | Fig. 25 |
| REPAIR PARTS (OPTION) | Fig. 26 |
| COMPONENT PARTS | Fig. 27 |

COMPONENT PARTS
COMPONENT PARTS
COMPONENT PARTS

Fig. 28
Fig. 29
Fig. 30

FIG. 1 CYLINDER HEAD

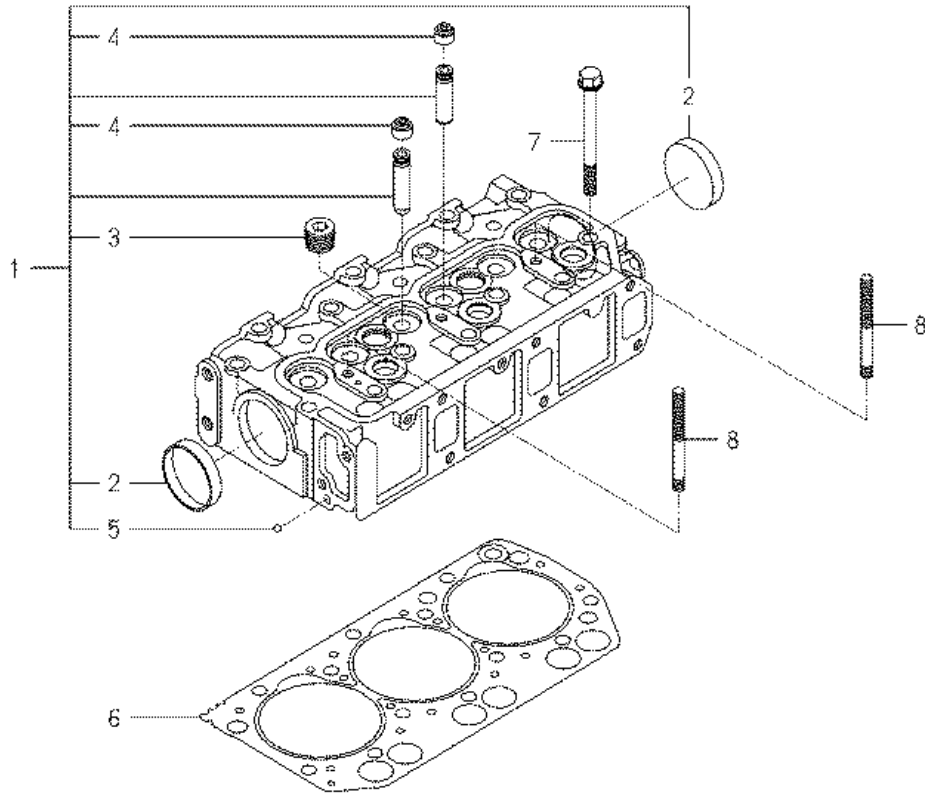

| KEY | Part Code | Description | S P C | Type of Model | | | | | | I T C | C O L | G R P | Remarks |
|-----|-----------------|---------------------|-------------|---------------|--|--|--|--|--|-------------|-------------|-------------|---------|
| | | | | E3CDG | | | | | | | | | |
| 1 | 6211-110-045-90 | CYLINDERHEAD ASSY | * | 1 | | | | | | | | | |
| 2 | 6209-610-003-00 | CUP/SEALING/50 | * | 2 | | | | | | | | | |
| 3 | 6209-605-004-10 | PLUG/PT1/2 | * | 5 | | | | | | | | | |
| 4 | 6212-569-002-00 | SEAL,OIL | * | 6 | | | | | | | | | |
| 5 | V682-200-000-60 | BALL | * | 1 | | | | | | | | | |
| 6 | 6211-141-023-50 | GASKET/CYLINDERHEAD | * | 1 | | | | | | | | | |
| 7 | 6209-000-005-00 | BOLT | * | 14 | | | | | | | | | |
| 8 | 6209-300-014-00 | STUD | * | 2 | | | | | | | | | |
| | | | | | | | | | | | | | |
| | | | | | | | | | | | | | |
| | | | | | | | | | | | | | |
| | | | | | | | | | | | | | |
| | | | | | | | | | | | | | |
| | | | | | | | | | | | | | |
| | | | | | | | | | | | | | |
| | | | | | | | | | | | | | |
| | | | | | | | | | | | | | |
| | | | | | | | | | | | | | |
| | | | | | | | | | | | | | |
| | | | | | | | | | | | | | |
| | | | | | | | | | | | | | |
| | | | | | | | | | | | | | |
| | | | | | | | | | | | | | |
| | | | | | | | | | | | | | |
| | | | | | | | | | | | | | |
| | | | | | | | | | | | | | |
| | | | | | | | | | | | | | |
| | | | | | | | | | | | | | |
| | | | | | | | | | | | | | |

FIG. 2 CYLINDER HEAD COVER

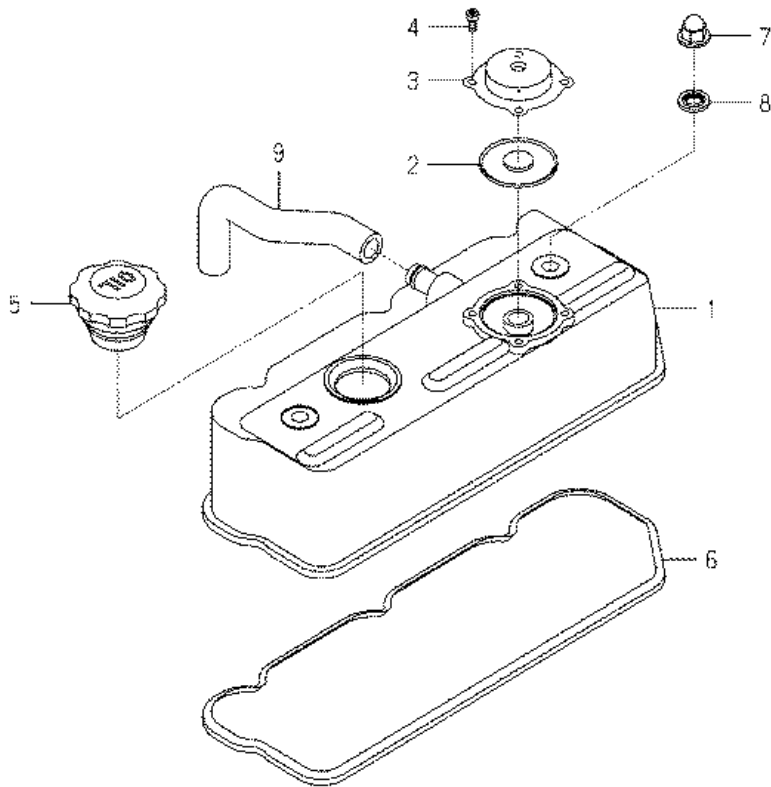

| KEY | Part Code | Description | S P C | Type of Model | | | | | I T C | C O L | G R P | Remarks |
|-----|-----------------|---------------------|-------------|---------------|--|--|--|--|-------------|-------------|-------------|---------|
| | | | | E3CDG | | | | | | | | |
| 1 | 6211-170-007-30 | COVER/CYLINDER HEAD | * | 1 | | | | | | | | |
| 2 | 6211-179-011-20 | RUBBERFLANGE | * | 1 | | | | | | | | |
| 3 | 6211-291-010-00 | COVER/BLOWBY | * | 1 | | | | | | | | |
| 4 | V195-164-008-30 | SCREW/TAPPING | * | 4 | | | | | | | | |
| 5 | 6211-751-001-10 | CAP,OIL FILLER | * | 1 | | | | | | | | |
| 6 | 6211-173-005-00 | SEAL/CYL HEAD/UNDER | * | 1 | | | | | | | | |
| 7 | 6209-490-002-10 | NUT/CAP | * | 2 | | | | | | | | |
| 8 | 6209-572-002-00 | GASKET | * | 2 | | | | | | | | |
| 9 | 6209-360-031-00 | HOSE/RUBBER | * | 1 | | | | | | | | |
| | | | | | | | | | | | | |
| | | | | | | | | | | | | |
| | | | | | | | | | | | | |
| | | | | | | | | | | | | |
| | | | | | | | | | | | | |
| | | | | | | | | | | | | |
| | | | | | | | | | | | | |
| | | | | | | | | | | | | |
| | | | | | | | | | | | | |
| | | | | | | | | | | | | |
| | | | | | | | | | | | | |
| | | | | | | | | | | | | |
| | | | | | | | | | | | | |
| | | | | | | | | | | | | |

FIG. 3 INLET MANIFOLD

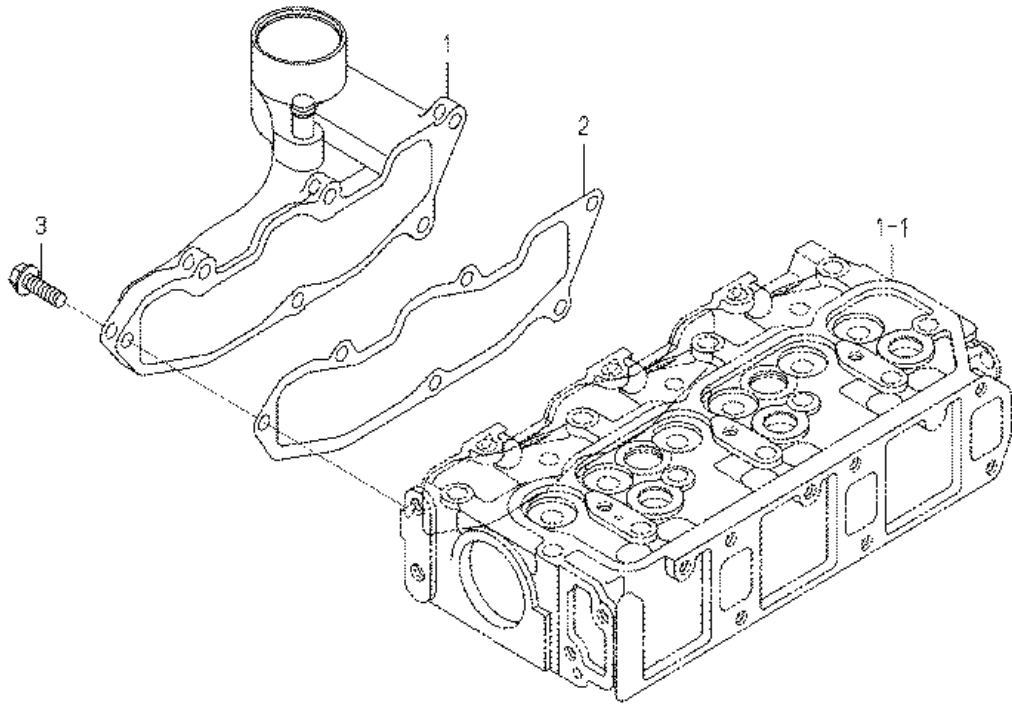

| KEY | Part Code | Description | S P C | Type of Model | | | | | | I T C | C O L | G R P | Remarks |
|-----|-----------------|----------------------|-------------|---------------|--|--|--|--|--|-------------|-------------|-------------|---------|
| | | | | E3CDG | | | | | | | | | |
| 1 | 6214-110-003-00 | MANIFOLD/INLET ASSY | * | 1 | | | | | | | | | |
| 2 | 6214-115-003-10 | GASKET/INLETMANIFOLD | * | 1 | | | | | | | | | |
| 3 | 6209-046-018-00 | BOLT/FLANGE | * | 6 | | | | | | | | | |
| | | | | | | | | | | | | | |
| | | | | | | | | | | | | | |
| | | | | | | | | | | | | | |
| | | | | | | | | | | | | | |
| | | | | | | | | | | | | | |
| | | | | | | | | | | | | | |
| | | | | | | | | | | | | | |
| | | | | | | | | | | | | | |
| | | | | | | | | | | | | | |
| | | | | | | | | | | | | | |
| | | | | | | | | | | | | | |
| | | | | | | | | | | | | | |
| | | | | | | | | | | | | | |
| | | | | | | | | | | | | | |
| | | | | | | | | | | | | | |
| | | | | | | | | | | | | | |
| | | | | | | | | | | | | | |
| | | | | | | | | | | | | | |
| | | | | | | | | | | | | | |

FIG. 4 EXHAUST MANIFOLD

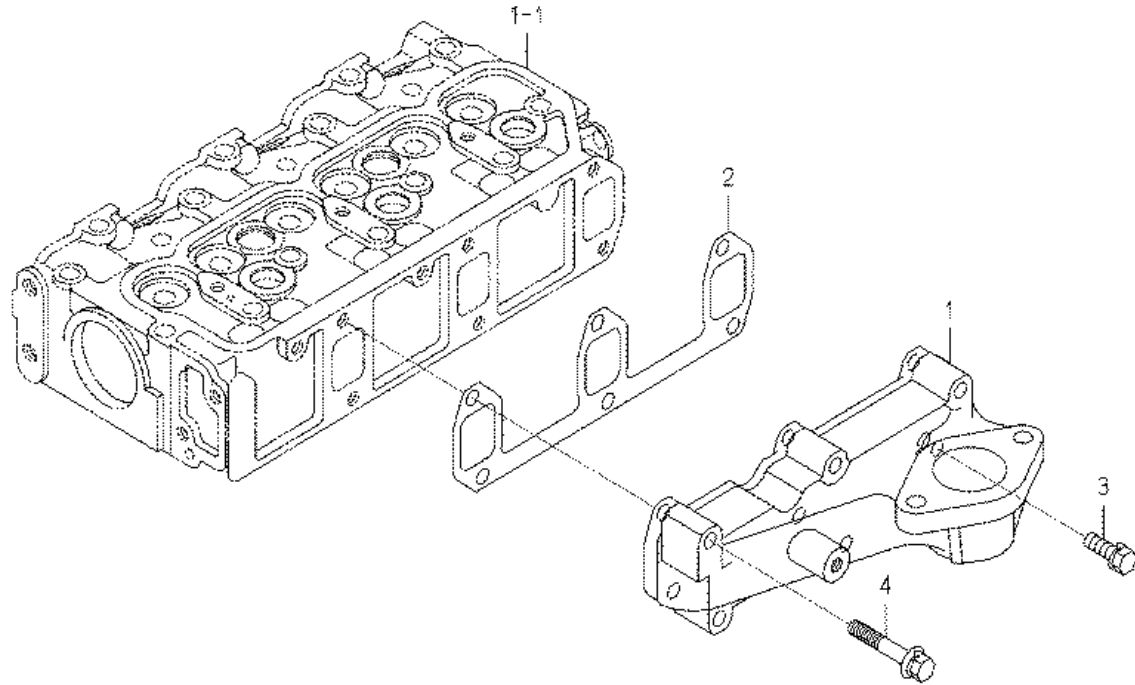

| KEY | Part Code | Description | S P C | Type of Model | | | | | I T C | C O L | G R P | Remarks |
|-----|-----------------|--------------------|-------------|---------------|--|--|--|--|-------------|-------------|-------------|---------|
| | | | | E3CDG | | | | | | | | |
| 1 | 6214-141-026-10 | MANIFOLD/EXHAUST | * | 1 | | | | | | | | |
| 2 | 6214-145-004-20 | GASHT/EXH MANIFOLD | * | 1 | | | | | | | | |
| 3 | V211-560-802-50 | BOLT,SEMS/M8X25 7T | * | 1 | | | | | | | | |
| 4 | 6509-030-037-00 | BOLT | * | 5 | | | | | | | | |
| | | | | | | | | | | | | |
| | | | | | | | | | | | | |
| | | | | | | | | | | | | |
| | | | | | | | | | | | | |
| | | | | | | | | | | | | |
| | | | | | | | | | | | | |
| | | | | | | | | | | | | |
| | | | | | | | | | | | | |
| | | | | | | | | | | | | |
| | | | | | | | | | | | | |
| | | | | | | | | | | | | |
| | | | | | | | | | | | | |
| | | | | | | | | | | | | |
| | | | | | | | | | | | | |
| | | | | | | | | | | | | |
| | | | | | | | | | | | | |
| | | | | | | | | | | | | |
| | | | | | | | | | | | | |
| | | | | | | | | | | | | |
| | | | | | | | | | | | | |
| | | | | | | | | | | | | |
| | | | | | | | | | | | | |
| | | | | | | | | | | | | |
| | | | | | | | | | | | | |
| | | | | | | | | | | | | |
| | | | | | | | | | | | | |
| | | | | | | | | | | | | |
| | | | | | | | | | | | | |
| | | | | | | | | | | | | |
| | | | | | | | | | | | | |
| | | | | | | | | | | | | |
| | | | | | | | | | | | | |

FIG. 5 CYLINDER BLOCK

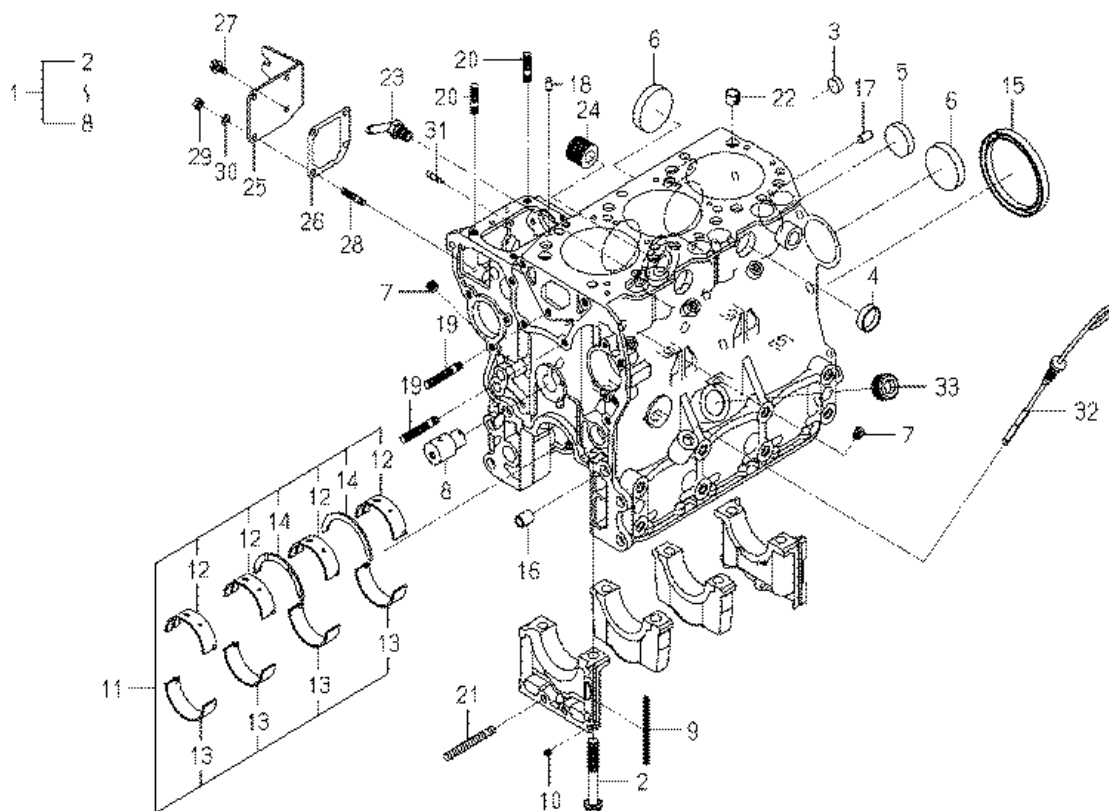

| KEY | Part Code | Description | S P C | Type of Model | | | | | | I T C | C O L | G R P | Remarks |
|-----|-----------------|-----------------------|-------------|---------------|--|--|--|--|--|-------------|-------------|-------------|---------|
| | | | | ESCDG | | | | | | | | | |
| 1 | 6211-210-056-70 | CYLINDERBLOCK ASSY | * | 1 | | | | | | | | | |
| 2 | 6209-000-006-00 | BOLT | * | 8 | | | | | | | | | |
| 3 | 6209-610-007-00 | CUP/SEALING/16 | * | 2 | | | | | | | | | |
| 4 | 6209-610-001-10 | CUP/SEALING/28 | * | 2 | | | | | | | | | |
| 5 | 6209-610-009-00 | CUP/SEALING/36 | * | 1 | | | | | | | | | |
| 6 | 6209-610-003-00 | CUP/SEALING/50 | * | 3 | | | | | | | | | |
| 7 | 6509-605-019-10 | PLUG | * | 8 | | | | | | | | | |
| 8 | 6212-531-008-20 | PIN/IDLEGEAR | * | 1 | | | | | | | | | |
| 9 | 6211-258-001-00 | SEAL, BEARING CAP | * | 4 | | | | | | | | | |
| 10 | 6211-258-002-00 | SEAL, BEARING CAP/7 | * | 2 | | | | | | | | | |
| 11 | 6211-510-008-00 | BEARING/CRANK SET | * | 1 | | | | | | | | | |
| 12 | 6211-511-007-00 | BEARING/CRANK/UPPER | * | 4 | | | | | | | | | |
| 13 | 6211-511-008-00 | BEARING/CRANK/LOWER | * | 4 | | | | | | | | | |
| 14 | 6211-599-004-00 | BEARING/THRUST/CRANK | * | 2 | | | | | | | | | |
| 15 | 6209-625-003-20 | OILSEAL | * | 1 | | | | | | | | | |
| 16 | 6209-749-001-20 | PIN/TUBE | * | 2 | | | | | | | | | |
| 17 | 6213-129-006-00 | PIN/STRAIGHT | * | 2 | | | | | | | | | |
| 18 | 6209-740-005-00 | PIN | * | 2 | | | | | | | | | |
| 19 | 6904-110-840-00 | STUD/M8X40 | * | 2 | | | | | | | | | |
| 20 | 6904-110-822-00 | STUD | * | 2 | | | | | | | | | |
| 21 | V251-340-806-00 | BOLT/STUD | * | 1 | | | | | | | | | |
| 22 | 6294-453-002-00 | DOWEL | * | 2 | | | | | | | | | |
| 23 | 6213-721-007-00 | PIPE/WATERDRAIN | * | 1 | | | | | | | | | |
| 24 | 6213-319-001-00 | CONNECTOR, OIL FILTER | * | 1 | | | | | | | | | |
| 25 | 6211-291-007-20 | COVER/INJECTIONPUMP | * | 1 | | | | | | | | | |
| 26 | 6211-292-001-20 | GASKET/COVER | * | 1 | | | | | | | | | |
| 27 | 6209-046-052-00 | BOLT/FLANGE | * | 1 | | | | | | | | | |
| 28 | 6209-300-006-10 | STUD | * | 3 | | | | | | | | | |
| 29 | V301-460-006-00 | | * | 3 | | | | | | | | | |
| 30 | V401-160-006-00 | WASHER, SP/M 6 | * | 3 | | | | | | | | | |

FIG. 5 CYLINDER BLOCK

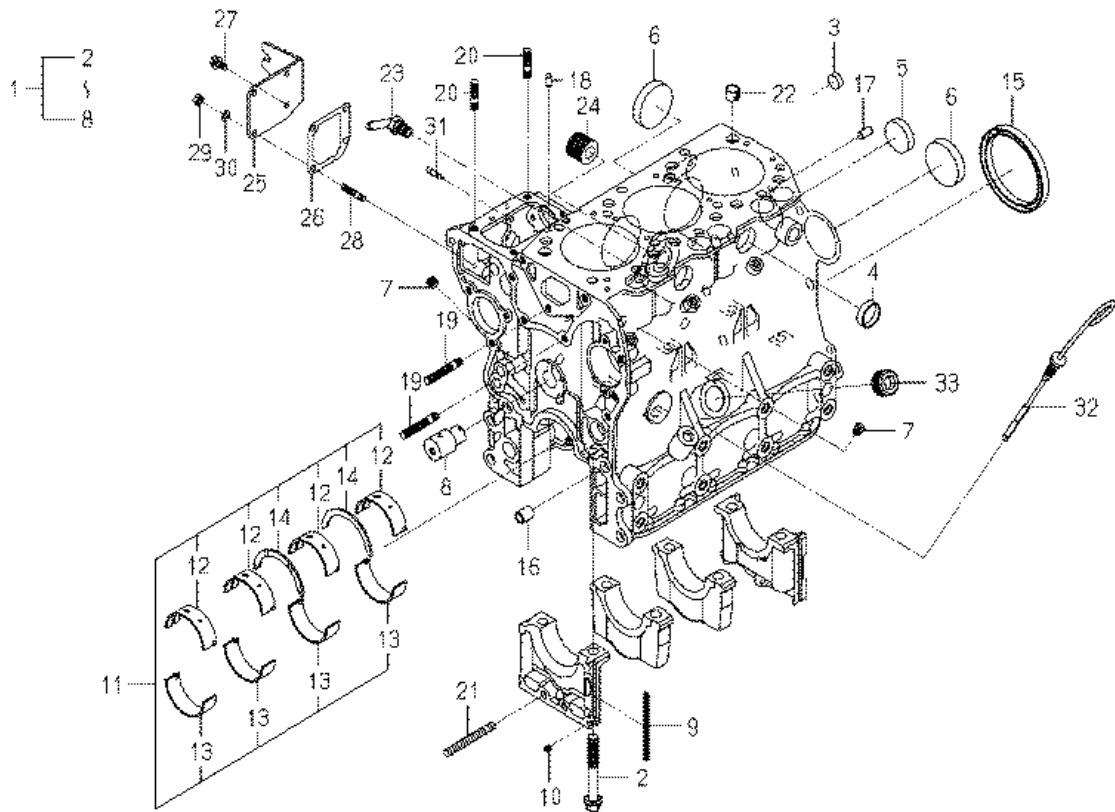

| KEY | Part Code | Description | S P C | Type of Model | | | | | | I T C | C O L | G R P | Remarks |
|-----|-----------------|-------------|-------------|---------------|--|--|--|--|--|-------------|-------------|-------------|---------|
| | | | | E3CDG | | | | | | | | | |
| 31 | 6215-549-013-00 | PIN | * | 1 | | | | | | | | | |
| 32 | 6211-760-015-20 | LEVELGAGE | * | 1 | | | | | | | | | |
| 33 | 6209-605-005-10 | PLUG/PT3/4 | * | 1 | | | | | | | | | |
| | | | | | | | | | | | | | |
| | | | | | | | | | | | | | |
| | | | | | | | | | | | | | |
| | | | | | | | | | | | | | |
| | | | | | | | | | | | | | |
| | | | | | | | | | | | | | |
| | | | | | | | | | | | | | |
| | | | | | | | | | | | | | |
| | | | | | | | | | | | | | |
| | | | | | | | | | | | | | |
| | | | | | | | | | | | | | |
| | | | | | | | | | | | | | |
| | | | | | | | | | | | | | |
| | | | | | | | | | | | | | |
| | | | | | | | | | | | | | |
| | | | | | | | | | | | | | |
| | | | | | | | | | | | | | |
| | | | | | | | | | | | | | |
| | | | | | | | | | | | | | |
| | | | | | | | | | | | | | |
| | | | | | | | | | | | | | |
| | | | | | | | | | | | | | |
| | | | | | | | | | | | | | |
| | | | | | | | | | | | | | |
| | | | | | | | | | | | | | |
| | | | | | | | | | | | | | |
| | | | | | | | | | | | | | |
| | | | | | | | | | | | | | |
| | | | | | | | | | | | | | |
| | | | | | | | | | | | | | |
| | | | | | | | | | | | | | |
| | | | | | | | | | | | | | |
| | | | | | | | | | | | | | |
| | | | | | | | | | | | | | |
| | | | | | | | | | | | | | |
| | | | | | | | | | | | | | |
| | | | | | | | | | | | | | |
| | | | | | | | | | | | | | |
| | | | | | | | | | | | | | |
| | | | | | | | | | | | | | |
| | | | | | | | | | | | | | |
| | | | | | | | | | | | | | |
| | | | | | | | | | | | | | |
| | | | | | | | | | | | | | |
| | | | | | | | | | | | | | |
| | | | | | | | | | | | | | |
| | | | | | | | | | | | | | |
| | | | | | | | | | | | | | |
| | | | | | | | | | | | | | |
| | | | | | | | | | | | | | |
| | | | | | | | | | | | | | |

FIG. 6 BEARING/UNDER SIZE (OPTION)

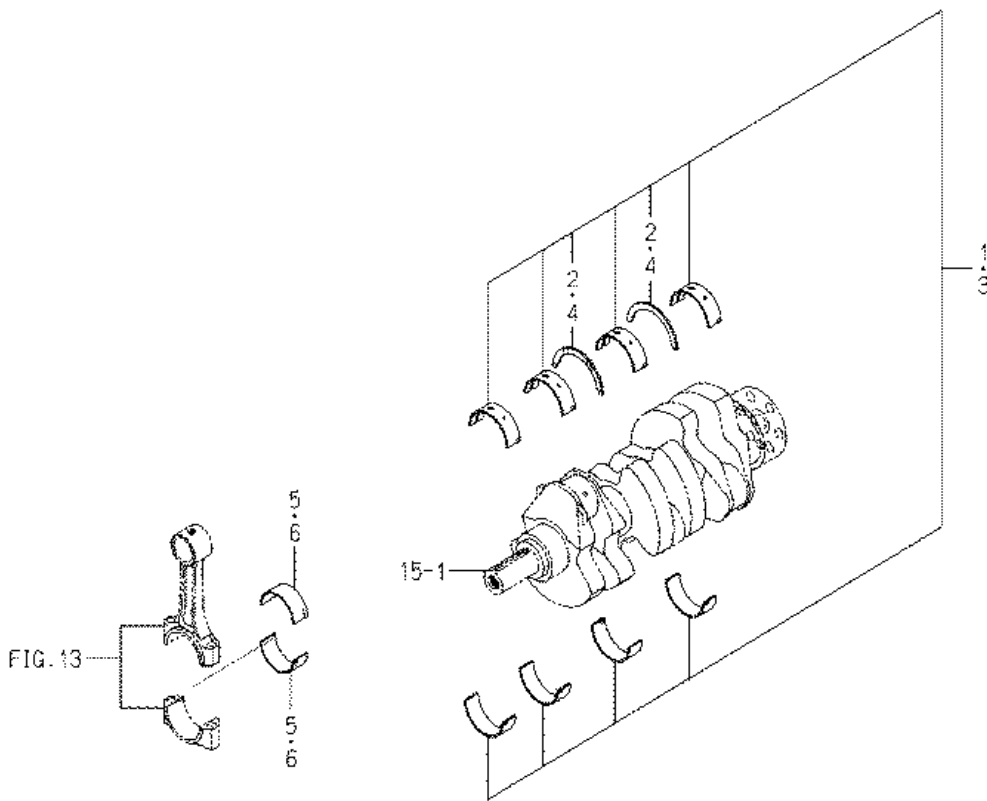

| KEY | Part Code | Description | S P C | Type of Model | | | | | | I T C | C O L | G R P | Remarks |
|-----|-----------------|----------------------|-------------|---------------|--|--|--|--|--|-------------|-------------|-------------|---------|
| | | | | E3CDG | | | | | | | | | |
| 1 | 6211-530-008-00 | BEARING/CRANK/UNDER | T | 1 | | | | | | | | | |
| 2 | 6211-599-004-00 | BEARING/THRUST/CRANK | T | 2 | | | | | | | | | |
| 3 | 6211-540-008-00 | BEARING/CRANK/UNDER | T | 1 | | | | | | | | | |
| 4 | 6211-599-004-00 | BEARING/THRUST/CRANK | T | 2 | | | | | | | | | |
| 5 | 6212-263-009-00 | BEARING/CONROD/UNDER | T | 6 | | | | | | | | | |
| 6 | 6212-264-009-00 | BEARING/CONROD/UNDER | T | 6 | | | | | | | | | |
| | | | | | | | | | | | | | |
| | | | | | | | | | | | | | |
| | | | | | | | | | | | | | |
| | | | | | | | | | | | | | |
| | | | | | | | | | | | | | |
| | | | | | | | | | | | | | |
| | | | | | | | | | | | | | |
| | | | | | | | | | | | | | |
| | | | | | | | | | | | | | |
| | | | | | | | | | | | | | |
| | | | | | | | | | | | | | |
| | | | | | | | | | | | | | |
| | | | | | | | | | | | | | |
| | | | | | | | | | | | | | |
| | | | | | | | | | | | | | |
| | | | | | | | | | | | | | |
| | | | | | | | | | | | | | |
| | | | | | | | | | | | | | |
| | | | | | | | | | | | | | |
| | | | | | | | | | | | | | |
| | | | | | | | | | | | | | |
| | | | | | | | | | | | | | |
| | | | | | | | | | | | | | |
| | | | | | | | | | | | | | |
| | | | | | | | | | | | | | |
| | | | | | | | | | | | | | |
| | | | | | | | | | | | | | |
| | | | | | | | | | | | | | |
| | | | | | | | | | | | | | |
| | | | | | | | | | | | | | |
| | | | | | | | | | | | | | |
| | | | | | | | | | | | | | |
| | | | | | | | | | | | | | |
| | | | | | | | | | | | | | |
| | | | | | | | | | | | | | |
| | | | | | | | | | | | | | |
| | | | | | | | | | | | | | |
| | | | | | | | | | | | | | |
| | | | | | | | | | | | | | |
| | | | | | | | | | | | | | |
| | | | | | | | | | | | | | |
| | | | | | | | | | | | | | |
| | | | | | | | | | | | | | |

FIG. 7 OIL PAN

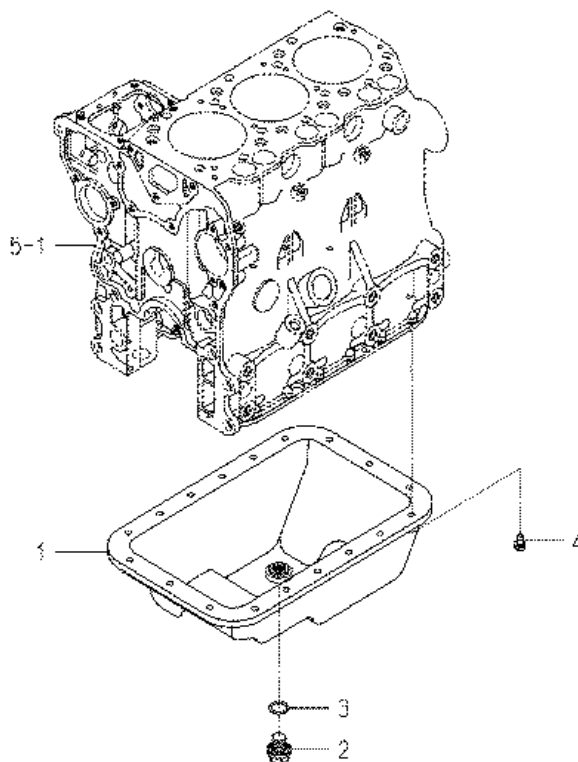

| KEY | Part Code | Description | S P C | Type of Model | | | | | | I T C | C O L | G R P | Remarks |
|-----|-----------------|--------------|-------------|---------------|--|--|--|--|--|-------------|-------------|-------------|---------|
| | | | | E3CDG | | | | | | | | | |
| 1 | 6211-361-022-20 | OILPAN COMP | * | 1 | | | | | | | | | |
| 2 | 6209-600-006-00 | PLUG/M14X1.5 | * | 1 | | | | | | | | | |
| 3 | V720-102-401-80 | O-RING/P18 | * | 1 | | | | | | | | | |
| 4 | 6209-046-034-00 | BOLT/FLANGE | * | 18 | | | | | | | | | |
| | | | | | | | | | | | | | |
| | | | | | | | | | | | | | |
| | | | | | | | | | | | | | |
| | | | | | | | | | | | | | |
| | | | | | | | | | | | | | |
| | | | | | | | | | | | | | |
| | | | | | | | | | | | | | |
| | | | | | | | | | | | | | |
| | | | | | | | | | | | | | |
| | | | | | | | | | | | | | |
| | | | | | | | | | | | | | |
| | | | | | | | | | | | | | |
| | | | | | | | | | | | | | |
| | | | | | | | | | | | | | |
| | | | | | | | | | | | | | |
| | | | | | | | | | | | | | |
| | | | | | | | | | | | | | |
| | | | | | | | | | | | | | |
| | | | | | | | | | | | | | |
| | | | | | | | | | | | | | |
| | | | | | | | | | | | | | |
| | | | | | | | | | | | | | |
| | | | | | | | | | | | | | |
| | | | | | | | | | | | | | |
| | | | | | | | | | | | | | |
| | | | | | | | | | | | | | |
| | | | | | | | | | | | | | |
| | | | | | | | | | | | | | |
| | | | | | | | | | | | | | |
| | | | | | | | | | | | | | |
| | | | | | | | | | | | | | |

FIG. 8 REAR PLATE

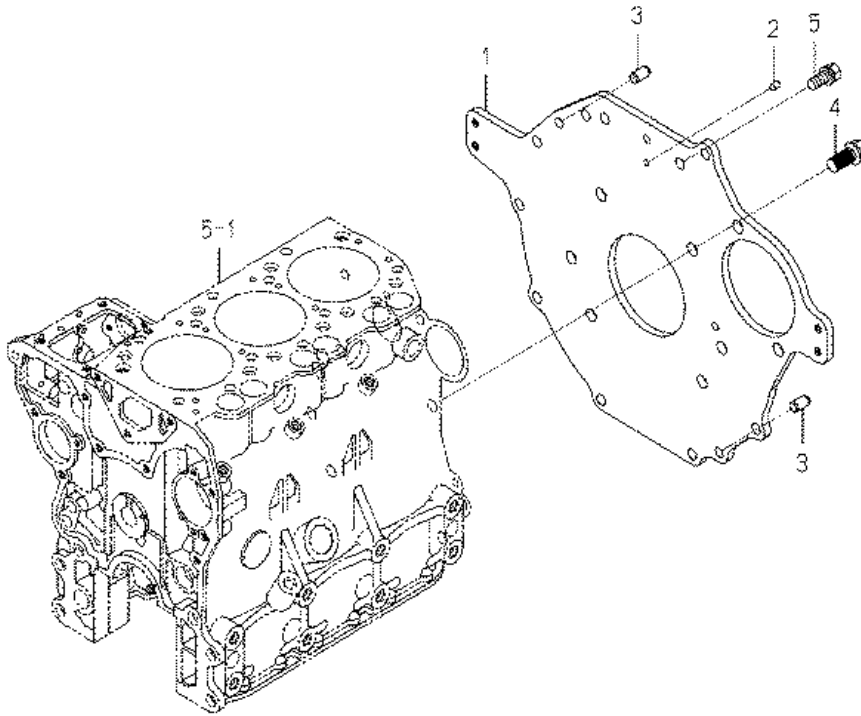

| KEY | Part Code | Description | S P C | Type of Model | | | | | | I T C | C O L | G R P | Remarks |
|-----|-----------------|-------------|-------------|---------------|--|--|--|--|--|-------------|-------------|-------------|---------|
| | | | | E3CDG | | | | | | | | | |
| 1 | 6211-341-017-10 | PLATE/REAR | * | 1 | | | | | | | | | |
| 2 | 6211-342-003-10 | POINTER | * | 1 | | | | | | | | | |
| 3 | V523-101-001-80 | PIN | * | 2 | | | | | | | | | |
| 4 | 6209-030-091-00 | BOLT/WS | * | 6 | | | | | | | | | |
| 5 | 6901-911-025-00 | BOLT | * | 2 | | | | | | | | | |
| | | | | | | | | | | | | | |
| | | | | | | | | | | | | | |
| | | | | | | | | | | | | | |
| | | | | | | | | | | | | | |
| | | | | | | | | | | | | | |
| | | | | | | | | | | | | | |
| | | | | | | | | | | | | | |
| | | | | | | | | | | | | | |
| | | | | | | | | | | | | | |
| | | | | | | | | | | | | | |
| | | | | | | | | | | | | | |
| | | | | | | | | | | | | | |
| | | | | | | | | | | | | | |
| | | | | | | | | | | | | | |
| | | | | | | | | | | | | | |
| | | | | | | | | | | | | | |
| | | | | | | | | | | | | | |
| | | | | | | | | | | | | | |
| | | | | | | | | | | | | | |
| | | | | | | | | | | | | | |
| | | | | | | | | | | | | | |
| | | | | | | | | | | | | | |
| | | | | | | | | | | | | | |
| | | | | | | | | | | | | | |
| | | | | | | | | | | | | | |
| | | | | | | | | | | | | | |
| | | | | | | | | | | | | | |
| | | | | | | | | | | | | | |
| | | | | | | | | | | | | | |
| | | | | | | | | | | | | | |
| | | | | | | | | | | | | | |
| | | | | | | | | | | | | | |
| | | | | | | | | | | | | | |

FIG. 9 TIMING GEAR CASE

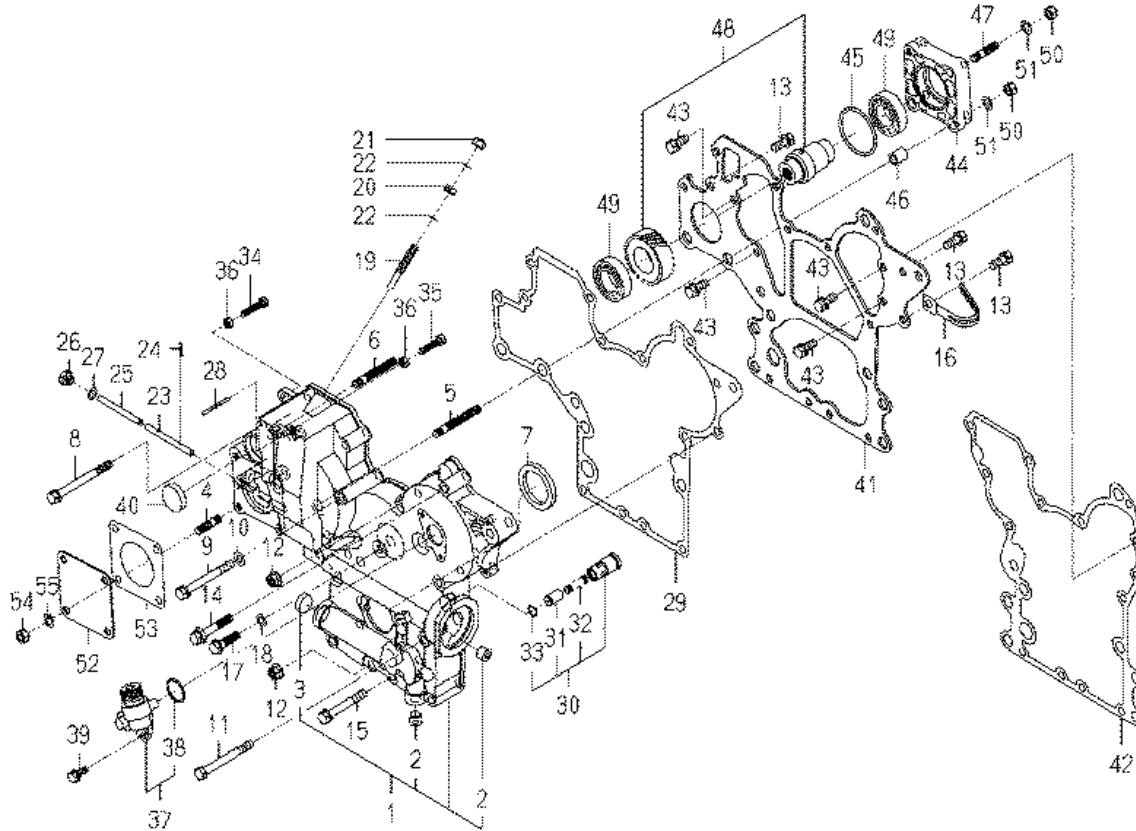

| KEY | Part Code | Description | S P C | Type of Model | | | | | I T C | C O L | G R P | Remarks |
|-----|-----------------|-------------------|-------------|---------------|--|--|--|--|-------------|-------------|-------------|---------|
| | | | | ESCDG | | | | | | | | |
| 1 | 6211-310-009-60 | GEARCASE ASSY | * | 1 | | | | | | | | |
| 2 | 6209-605-003-00 | PLUG/PT1/4 | * | 2 | | | | | | | | |
| 3 | 6209-610-004-00 | CUP/SEALING/20 | * | 1 | | | | | | | | |
| 4 | 6904-110-822-00 | STUD | * | 4 | | | | | | | | |
| 5 | 6904-110-855-00 | STUD | * | 2 | | | | | | | | |
| 6 | 6904-110-850-00 | STUD | * | 1 | | | | | | | | |
| 7 | 6209-625-002-00 | SEAL,OIL | * | 1 | | | | | | | | |
| 8 | 6209-030-005-00 | BOLT/M8X85 | * | 1 | | | | | | | | |
| 9 | 6209-030-006-00 | BOLT/M8X75 | * | 1 | | | | | | | | |
| 10 | 6209-500-006-00 | WASHER/08X16X1.2 | * | 1 | | | | | | | | |
| 11 | V201-360-807-50 | BOLT | * | 1 | | | | | | | | |
| 12 | 3817-401-001-00 | NUT/M08 | * | 2 | | | | | | | | |
| 13 | V211-560-802-00 | BOLT/M8X20 | * | 3 | | | | | | | | |
| 14 | 6509-030-037-00 | BOLT | * | 3 | | | | | | | | |
| 15 | 6209-030-095-00 | BOLT/WS | * | 4 | | | | | | | | |
| 16 | 1425-621-004-00 | CLAMP,HARNESS | * | 1 | | | | | | | | |
| 17 | 6209-046-010-00 | BOLT/FLANGE | * | 1 | | | | | | | | |
| 18 | 6209-500-003-00 | WASHER/08X14X01 | * | 1 | | | | | | | | |
| 19 | 6215-546-003-10 | STOPPER/FULLLOAD | * | 1 | | | | | | | | |
| 20 | 6209-409-001-00 | NUT/M8 | * | 1 | | | | | | | | |
| 21 | V341-120-008-00 | NUT,CAP/M 8 | * | 1 | | | | | | | | |
| 22 | 6209-920-002-00 | PACKING | * | 2 | | | | | | | | |
| 23 | 6215-542-004-20 | PIN/ARM | * | 1 | | | | | | | | |
| 24 | P117-303-003-00 | PIN/SNAP | * | 2 | | | | | | | | |
| 25 | 6215-542-005-10 | PIN | * | 1 | | | | | | | | |
| 26 | 6209-600-004-00 | PLUG/SCREW | * | 1 | | | | | | | | |
| 27 | 6209-500-003-00 | WASHER/08X14X01 | * | 1 | | | | | | | | |
| 28 | 6209-740-001-00 | PIN,GROOVE | * | 1 | | | | | | | | |
| 29 | 6211-312-005-10 | GASKET/GEARCASE | * | 1 | | | | | | | | |
| 30 | 6213-160-003-10 | VALVE/RELIEF ASSY | * | 1 | | | | | | | | |

FIG. 9 TIMING GEAR CASE

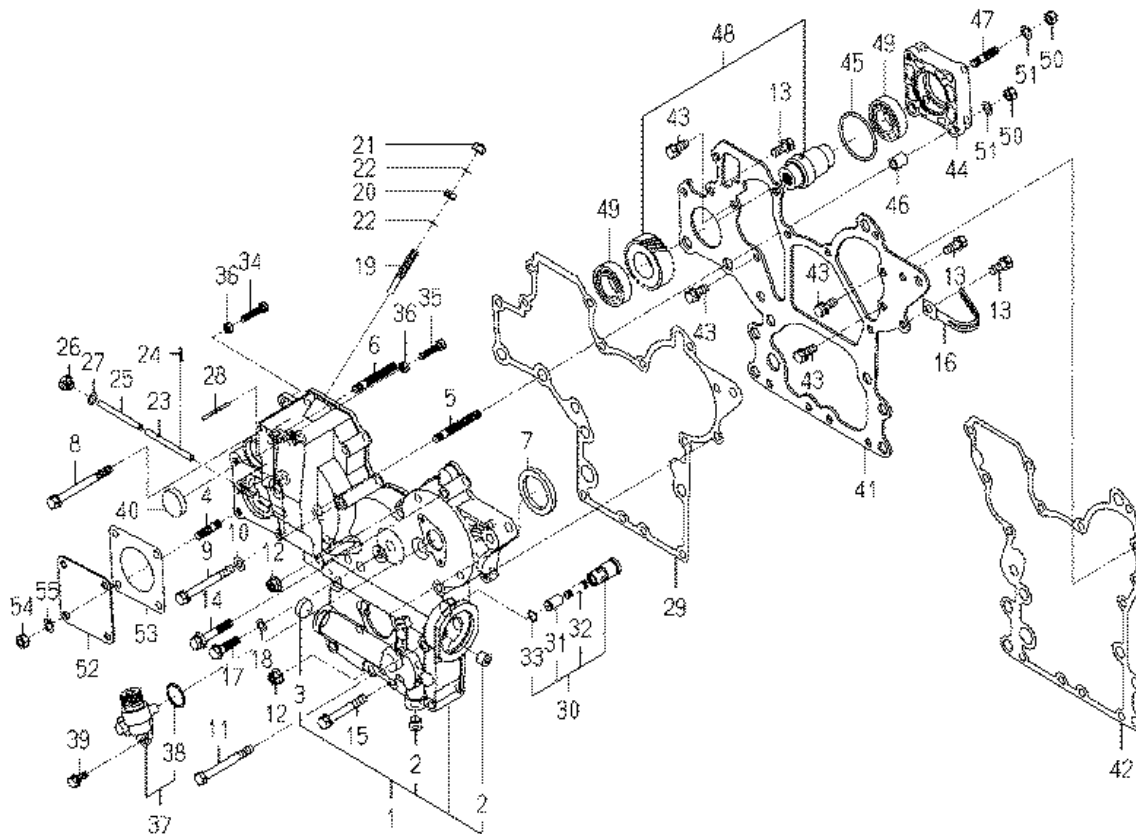

| KEY | Part Code | Description | S P C | Type of Model | | | | | I T C | C O L | G R P | Remarks |
|-----|-----------------|----------------------|-------------|---------------|--|--|--|--|-------------|-------------|-------------|---------|
| | | | | ESCDG | | | | | | | | |
| 31 | 6213-161-003-10 | PISTON/VALVE/RELIEF | * | 1 | | | | | | | | |
| 32 | 6213-164-001-00 | SPRING/RELIEF VALVE | * | 1 | | | | | | | | |
| 33 | V705-140-012-00 | RING,SNAP/12 C | * | 1 | | | | | | | | |
| 34 | 6209-050-001-00 | BOLT/M6 | * | 1 | | | | | | | | |
| 35 | 6209-050-002-00 | BOLT/M6 | * | 1 | | | | | | | | |
| 36 | 6909-110-406-00 | NUT | * | 2 | | | | | | | | |
| 37 | 6219-310-003-20 | DRIVE/TACHOMETE ASSY | * | 1 | | | | | | | | |
| 38 | V723-102-002-40 | RING/O | * | 1 | | | | | | | | |
| 39 | 6209-046-035-00 | BOLT/FLANGE | * | 2 | | | | | | | | |
| 40 | 3625-540-004-00 | CAP,BLANK/30 | * | 1 | | | | | | | | |
| 41 | 6211-311-013-20 | PLATE/FRONT | * | 1 | | | | | | | | |
| 42 | 6211-312-006-10 | GASKET/PLATE | * | 1 | | | | | | | | |
| 43 | 6902-050-816-00 | BOLT | * | 4 | | | | | | | | |
| 44 | 6211-319-003-00 | SPACER | * | 1 | | | | | | | | |
| 45 | V723-102-005-00 | O-RING 1A S50 | * | 1 | | | | | | | | |
| 46 | 6209-749-001-20 | PIN/TUBE | * | 2 | | | | | | | | |
| 47 | 6904-110-822-00 | STUD | * | 1 | | | | | | | | |
| 48 | 6212-530-005-10 | SHAFT/HYDRAULIC ASSY | * | 1 | | | | | | | | |
| 49 | V600-110-600-50 | BEARING,RB/6005 | * | 2 | | | | | | | | |
| 50 | 6909-110-408-00 | NUT/M8 | * | 4 | | | | | | | | |
| 51 | V401-160-008-00 | WASHER,SP/M 8 | * | 4 | | | | | | | | |
| 52 | 6511-321-083-00 | COVER | * | 1 | | | | | | | | |
| 53 | 6211-322-002-00 | GASKET/COVER | * | 1 | | | | | | | | |
| 54 | 6909-110-408-00 | NUT/M8 | * | 4 | | | | | | | | |
| 55 | V401-160-008-00 | WASHER,SP/M 8 | * | 4 | | | | | | | | |
| | | | | | | | | | | | | |
| | | | | | | | | | | | | |
| | | | | | | | | | | | | |
| | | | | | | | | | | | | |

FIG. 10 HANGER

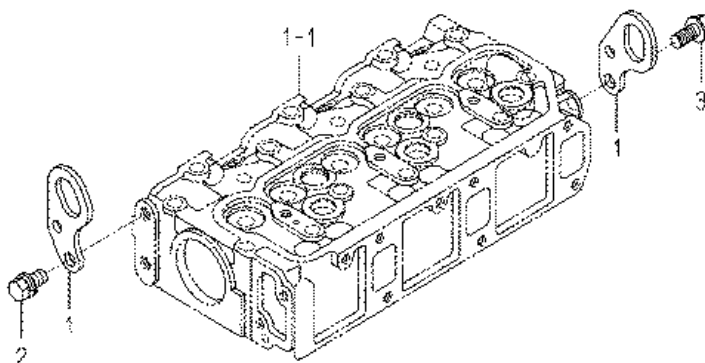

| KEY | Part Code | Description | S P C | Type of Model | | | | | | I T C | C O L | G R P | Remarks |
|-----|-----------------|------------------|-------------|---------------|--|--|--|--|--|-------------|-------------|-------------|---------|
| | | | | E3CDG | | | | | | | | | |
| 1 | 6211-777-007-30 | HANGER | * | 2 | | | | | | | | | |
| 2 | 6901-911-020-00 | BOLT,SEMS/M10X20 | * | 1 | | | | | | | | | |
| 3 | 6209-046-044-00 | BOLT/FLANGE | * | 1 | | | | | | | | | |
| | | | | | | | | | | | | | |
| | | | | | | | | | | | | | |
| | | | | | | | | | | | | | |
| | | | | | | | | | | | | | |
| | | | | | | | | | | | | | |
| | | | | | | | | | | | | | |
| | | | | | | | | | | | | | |
| | | | | | | | | | | | | | |
| | | | | | | | | | | | | | |
| | | | | | | | | | | | | | |
| | | | | | | | | | | | | | |
| | | | | | | | | | | | | | |
| | | | | | | | | | | | | | |
| | | | | | | | | | | | | | |
| | | | | | | | | | | | | | |
| | | | | | | | | | | | | | |
| | | | | | | | | | | | | | |
| | | | | | | | | | | | | | |

FIG. 11 VALVE

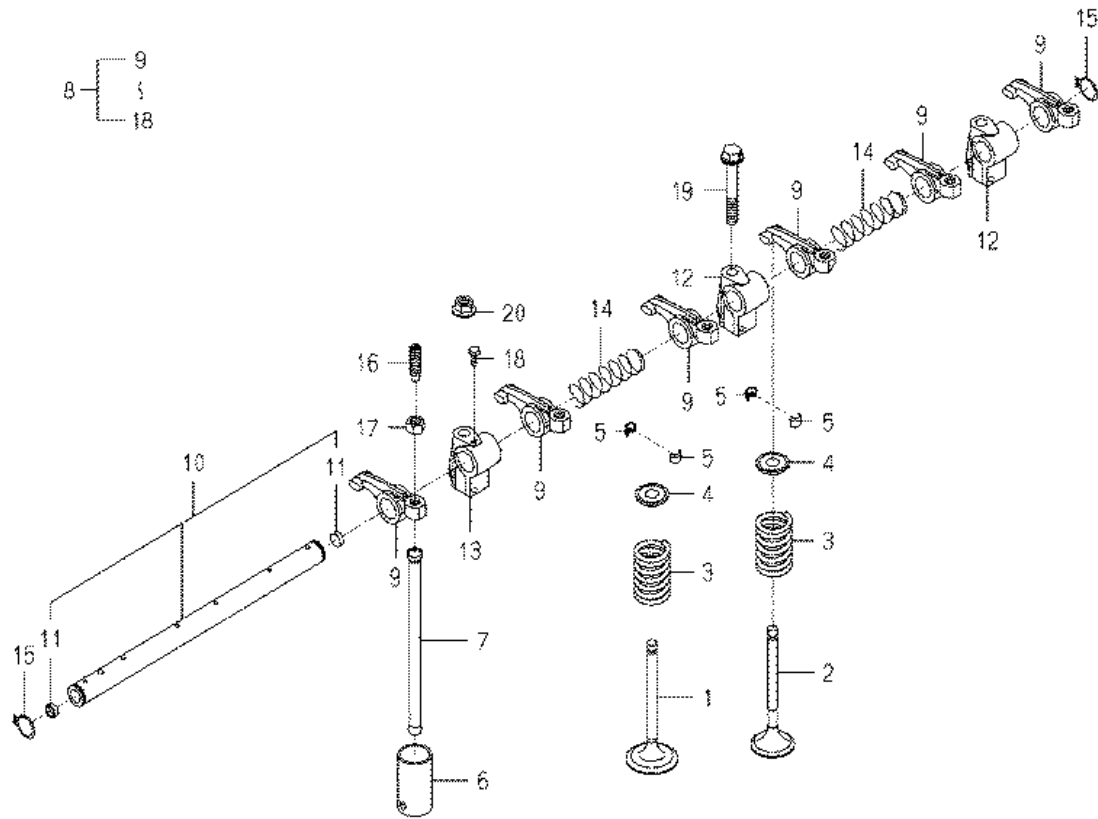

| KEY | Part Code | Description | S P C | Type of Model | | | | | I T C | C O L | G R P | Remarks |
|-----|-----------------|----------------------|-------------|---------------|--|--|--|--|-------------|-------------|-------------|---------|
| | | | | E3CDG | | | | | | | | |
| 1 | 6212-551-020-00 | VALVE/INTAKE | * | 3 | | | | | | | | |
| 2 | 6212-552-008-00 | VALVE/EXHAUST | * | 3 | | | | | | | | |
| 3 | 6212-561-003-00 | SPRING/VALVE | * | 6 | | | | | | | | |
| 4 | 6212-563-001-00 | SEAT,VALVE SPRING | * | 6 | | | | | | | | |
| 5 | 6212-565-001-00 | CUTTER,VALVE | * | 12 | | | | | | | | |
| 6 | 6212-571-002-30 | TAPPET | * | 6 | | | | | | | | |
| 7 | 6212-575-003-00 | PUSHROD | * | 6 | | | | | | | | |
| 8 | 6212-600-009-20 | ROCKERSHAFT ASSY | * | 1 | | | | | | | | |
| 9 | 6212-611-004-10 | ROCKERARM | * | 6 | | | | | | | | |
| 10 | 6212-620-008-20 | SHAFT/ROCKERARM ASSY | * | 1 | | | | | | | | |
| 11 | 6212-626-002-10 | PLUG | * | 2 | | | | | | | | |
| 12 | 6212-628-010-10 | BRACKET/ROCKERSHAFT | * | 2 | | | | | | | | |
| 13 | 6212-628-011-10 | BRACKET/ROCKERSHAFT | * | 1 | | | | | | | | |
| 14 | 6209-940-004-00 | SPRING | * | 2 | | | | | | | | |
| 15 | V704-140-016-00 | RING,SNAP/16 C | * | 2 | | | | | | | | |
| 16 | 6212-616-002-00 | SCREW ADJUST | * | 6 | | | | | | | | |
| 17 | 6209-409-003-00 | NUT | * | 6 | | | | | | | | |
| 18 | 6209-000-002-00 | BOLT | * | 1 | | | | | | | | |
| 19 | 6209-046-022-00 | BOLT/FLAMGE | * | 1 | | | | | | | | |
| 20 | 3817-401-001-00 | NUT/M08 | * | 2 | | | | | | | | |
| | | | | | | | | | | | | |
| | | | | | | | | | | | | |
| | | | | | | | | | | | | |
| | | | | | | | | | | | | |
| | | | | | | | | | | | | |
| | | | | | | | | | | | | |
| | | | | | | | | | | | | |
| | | | | | | | | | | | | |
| | | | | | | | | | | | | |
| | | | | | | | | | | | | |
| | | | | | | | | | | | | |

FIG. 12 CAM SHAFT

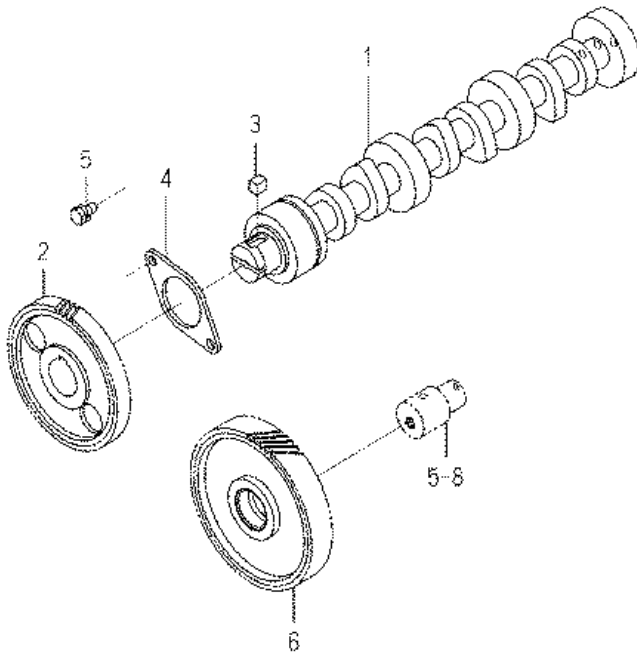

| KEY | Part Code | Description | S P C | Type of Model | | | | | | I T C | C O L | G R P | Remarks |
|-----|-----------------|-----------------|-------------|---------------|--|--|--|--|--|-------------|-------------|-------------|---------|
| | | | | E3CDG | | | | | | | | | |
| 1 | 6212-511-005-00 | CAMSHAFT | * | 1 | | | | | | | | | |
| 2 | 6212-522-004-00 | GEAR/CAMSHAFT | * | 1 | | | | | | | | | |
| 3 | 6209-730-005-00 | KEY/07X05X09 | * | 1 | | | | | | | | | |
| 4 | 6212-535-007-00 | PLATE/THRUST | * | 1 | | | | | | | | | |
| 5 | 6901-910-612-00 | BOLT,SEMS/M6X12 | * | 2 | | | | | | | | | |
| 6 | 6212-523-006-40 | GEAR/IDLE ASSY | * | 1 | | | | | | | | | |
| | | | | | | | | | | | | | |
| | | | | | | | | | | | | | |
| | | | | | | | | | | | | | |
| | | | | | | | | | | | | | |
| | | | | | | | | | | | | | |
| | | | | | | | | | | | | | |
| | | | | | | | | | | | | | |
| | | | | | | | | | | | | | |
| | | | | | | | | | | | | | |
| | | | | | | | | | | | | | |
| | | | | | | | | | | | | | |
| | | | | | | | | | | | | | |
| | | | | | | | | | | | | | |
| | | | | | | | | | | | | | |
| | | | | | | | | | | | | | |
| | | | | | | | | | | | | | |
| | | | | | | | | | | | | | |
| | | | | | | | | | | | | | |
| | | | | | | | | | | | | | |
| | | | | | | | | | | | | | |
| | | | | | | | | | | | | | |
| | | | | | | | | | | | | | |
| | | | | | | | | | | | | | |
| | | | | | | | | | | | | | |
| | | | | | | | | | | | | | |
| | | | | | | | | | | | | | |
| | | | | | | | | | | | | | |

FIG. 13 PISTON

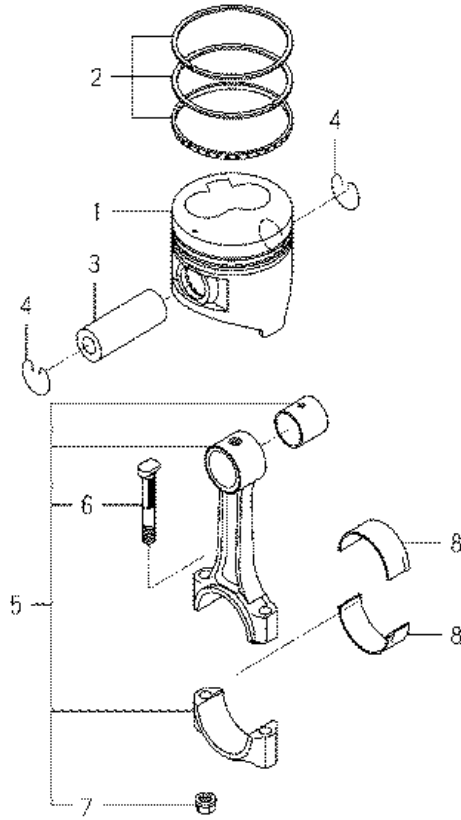

| KEY | Part Code | Description | S P C | Type of Model | | | | | | I T C | C O L | G R P | Remarks |
|-----|-----------------|--------------------|-------------|---------------|--|--|--|--|--|-------------|-------------|-------------|---------|
| | | | | E3CDG | | | | | | | | | |
| 1 | 6212-111-039-80 | PISTON | * | 3 | | | | | | | | | |
| 2 | 6212-121-013-30 | RING/PISTON SET | * | 3 | | | | | | | | | |
| 3 | 6512-211-018-00 | PIN,PISTON | * | 3 | | | | | | | | | |
| 4 | 6909-950-115-00 | RING SNAP | * | 6 | | | | | | | | | |
| 5 | 6212-230-011-00 | CONNECTINGROD ASSY | * | 3 | | | | | | | | | |
| 6 | 6212-235-002-20 | BOLT/CONNECTINGROD | * | 6 | | | | | | | | | |
| 7 | 6209-440-002-10 | NUT/FLANGE | * | 6 | | | | | | | | | |
| 8 | 6212-261-009-10 | BEARING/CON ROD | * | 6 | | | | | | | | | |
| | | | | | | | | | | | | | |
| | | | | | | | | | | | | | |
| | | | | | | | | | | | | | |
| | | | | | | | | | | | | | |
| | | | | | | | | | | | | | |
| | | | | | | | | | | | | | |
| | | | | | | | | | | | | | |
| | | | | | | | | | | | | | |
| | | | | | | | | | | | | | |
| | | | | | | | | | | | | | |
| | | | | | | | | | | | | | |
| | | | | | | | | | | | | | |
| | | | | | | | | | | | | | |
| | | | | | | | | | | | | | |
| | | | | | | | | | | | | | |
| | | | | | | | | | | | | | |
| | | | | | | | | | | | | | |
| | | | | | | | | | | | | | |
| | | | | | | | | | | | | | |
| | | | | | | | | | | | | | |
| | | | | | | | | | | | | | |
| | | | | | | | | | | | | | |
| | | | | | | | | | | | | | |
| | | | | | | | | | | | | | |
| | | | | | | | | | | | | | |
| | | | | | | | | | | | | | |
| | | | | | | | | | | | | | |
| | | | | | | | | | | | | | |
| | | | | | | | | | | | | | |
| | | | | | | | | | | | | | |
| | | | | | | | | | | | | | |
| | | | | | | | | | | | | | |
| | | | | | | | | | | | | | |
| | | | | | | | | | | | | | |
| | | | | | | | | | | | | | |

FIG. 14 PISTON/OVER SIZE (OPTION)

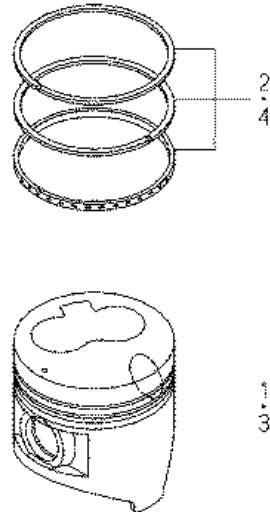

| KEY | Part Code | Description | S P C | Type of Model | | | | | | I T C | C O L | G R P | Remarks |
|-----|-----------------|--------------------|-------------|---------------|--|--|--|--|--|-------------|-------------|-------------|---------|
| | | | | E3CDG | | | | | | | | | |
| 1 | 6212-114-039-80 | PISTON/OV | T | 3 | | | | | | | | | |
| 2 | 6212-124-013-30 | RING/PISTON/OV SET | T | 3 | | | | | | | | | |
| 3 | 6212-116-039-80 | PISTON/OV | T | 3 | | | | | | | | | |
| 4 | 6212-126-013-30 | RING/PISTON/OV SET | T | 3 | | | | | | | | | |
| | | | | | | | | | | | | | |
| | | | | | | | | | | | | | |
| | | | | | | | | | | | | | |
| | | | | | | | | | | | | | |
| | | | | | | | | | | | | | |
| | | | | | | | | | | | | | |
| | | | | | | | | | | | | | |
| | | | | | | | | | | | | | |
| | | | | | | | | | | | | | |
| | | | | | | | | | | | | | |
| | | | | | | | | | | | | | |
| | | | | | | | | | | | | | |
| | | | | | | | | | | | | | |
| | | | | | | | | | | | | | |
| | | | | | | | | | | | | | |
| | | | | | | | | | | | | | |
| | | | | | | | | | | | | | |
| | | | | | | | | | | | | | |
| | | | | | | | | | | | | | |
| | | | | | | | | | | | | | |

FIG. 15 CRANK SHAFT

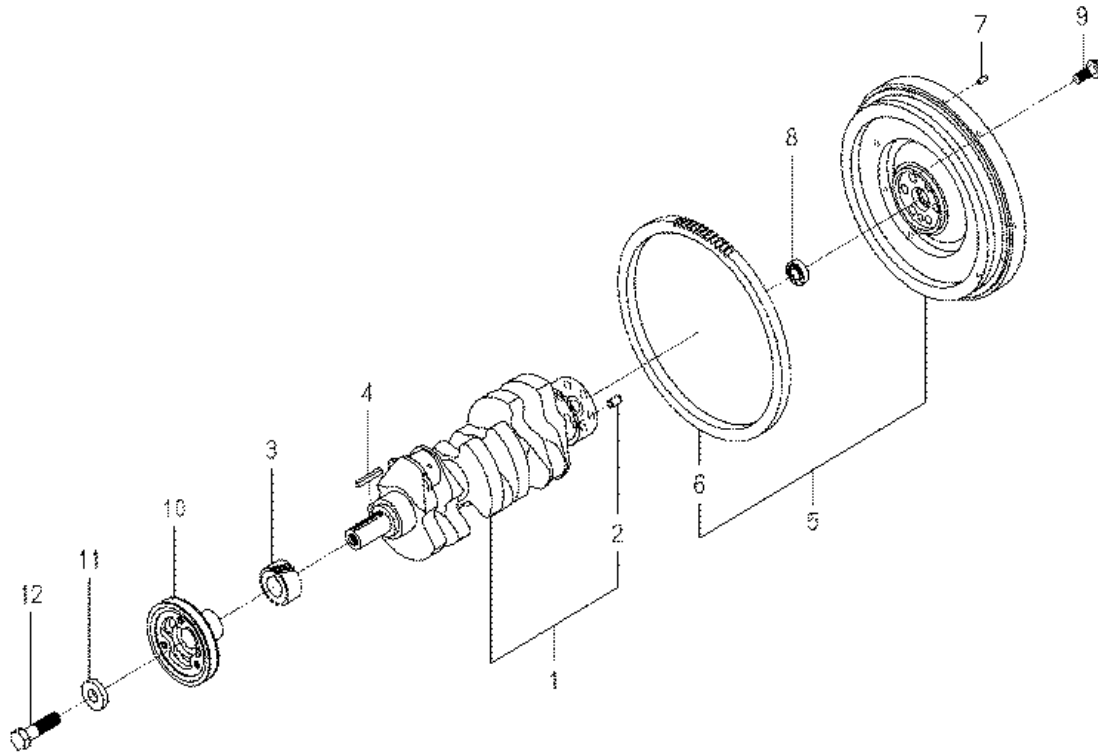

| KEY | Part Code | Description | S P C | Type of Model | | | | | | I T C | C O L | G R P | Remarks |
|-----|-----------------|-------------------|-------------|---------------|--|--|--|--|--|-------------|-------------|-------------|---------|
| | | | | E3CDG | | | | | | | | | |
| 1 | 6212-310-011-40 | CRANKSHAFT ASSY | * | 1 | | | | | | | | | |
| 2 | V523-101-001-80 | PIN | * | 1 | | | | | | | | | |
| 3 | 6212-521-008-00 | GEAR/CRANK | * | 1 | | | | | | | | | |
| 4 | 6209-730-006-00 | KEY/07X05X43 | * | 1 | | | | | | | | | |
| 5 | 6212-330-040-40 | FLYWHEEL ASSY | * | 1 | | | | | | | | | |
| 6 | 6212-333-002-00 | RINGGEAR | * | 1 | | | | | | | | | |
| 7 | 6213-129-004-00 | PIN/STRAIGHT | * | 3 | | | | | | | | | |
| 8 | V600-150-600-20 | BEARING,RB/6002SS | * | 1 | | | | | | | | | |
| 9 | 6209-046-015-00 | BOLT/FLANGE | * | 6 | | | | | | | | | |
| 10 | 6212-371-034-10 | PULLEY/CRANK | * | 1 | | | | | | | | | |
| 11 | 6212-379-001-00 | WASHER | * | 1 | | | | | | | | | |
| 12 | 6901-066-645-00 | BOLT | * | 1 | | | | | | | | | |
| | | | | | | | | | | | | | |
| | | | | | | | | | | | | | |
| | | | | | | | | | | | | | |
| | | | | | | | | | | | | | |
| | | | | | | | | | | | | | |
| | | | | | | | | | | | | | |
| | | | | | | | | | | | | | |
| | | | | | | | | | | | | | |
| | | | | | | | | | | | | | |
| | | | | | | | | | | | | | |
| | | | | | | | | | | | | | |
| | | | | | | | | | | | | | |
| | | | | | | | | | | | | | |
| | | | | | | | | | | | | | |
| | | | | | | | | | | | | | |
| | | | | | | | | | | | | | |

FIG. 16 OIL PUMP

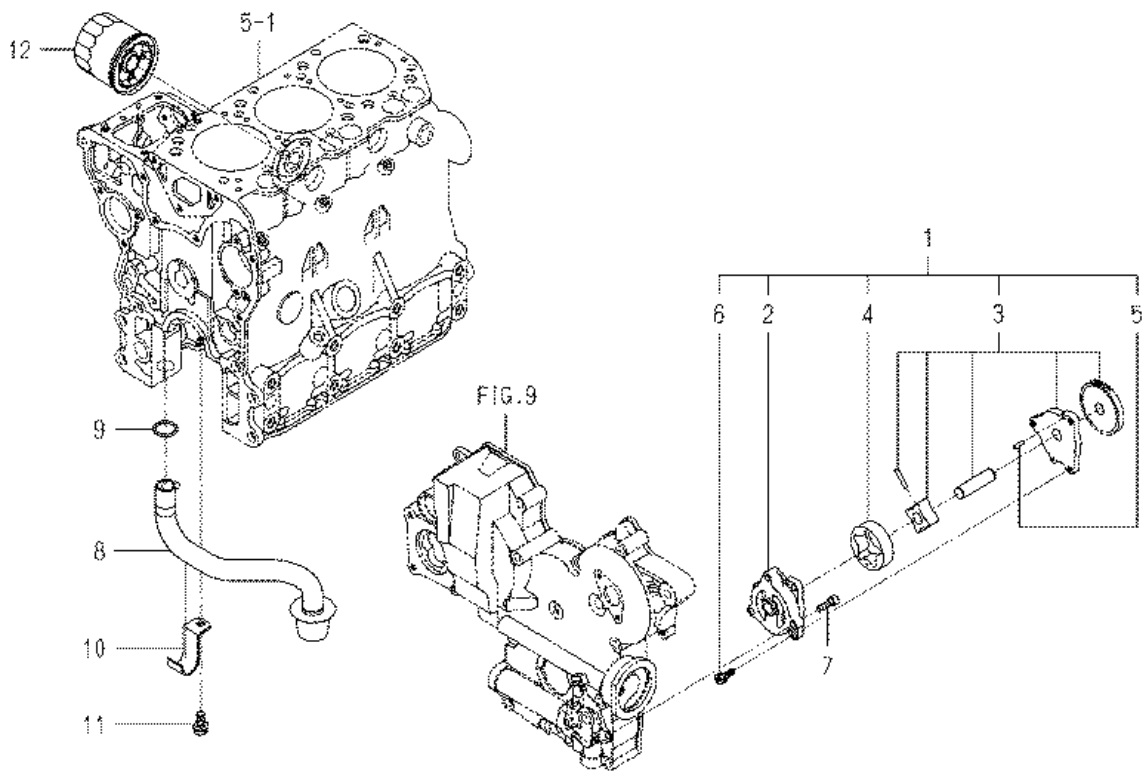

| KEY | Part Code | Description | S P C | Type of Model | | | | | | I T C | C O L | G R P | Remarks |
|-----|-----------------|---------------------|-------------|---------------|--|--|--|--|--|-------------|-------------|-------------|---------|
| | | | | E3CDG | | | | | | | | | |
| 1 | 6213-100-004-30 | OILPUMP ASSY | * | 1 | | | | | | | | | |
| 2 | 6213-111-002-20 | BODY/OILPUMP | * | 1 | | | | | | | | | |
| 3 | 6213-120-002-30 | GEAR/OILPUMP ASSY | * | 1 | | | | | | | | | |
| 4 | 6213-125-002-10 | ROTOR/OUTER | * | 1 | | | | | | | | | |
| 5 | 6213-129-003-00 | PIN/STRAIGHT | * | 2 | | | | | | | | | |
| 6 | 6213-119-001-00 | BOLT/WS | * | 3 | | | | | | | | | |
| 7 | V220-540-602-00 | SCREW/SOCKET | * | 3 | | | | | | | | | |
| 8 | 6213-140-012-00 | STRAINER COMP | * | 1 | | | | | | | | | |
| 9 | V720-103-502-20 | O-RING/P22 | * | 1 | | | | | | | | | |
| 10 | 6213-149-003-20 | CLAMP/STRAINER | * | 1 | | | | | | | | | |
| 11 | 6209-046-016-00 | BOLT/FLANGE | * | 1 | | | | | | | | | |
| 12 | 6213-240-002-10 | CARTRIDGE/OILFILTER | * | 1 | | | | | | | | | |
| | | | | | | | | | | | | | |
| | | | | | | | | | | | | | |
| | | | | | | | | | | | | | |
| | | | | | | | | | | | | | |
| | | | | | | | | | | | | | |
| | | | | | | | | | | | | | |
| | | | | | | | | | | | | | |
| | | | | | | | | | | | | | |
| | | | | | | | | | | | | | |
| | | | | | | | | | | | | | |
| | | | | | | | | | | | | | |
| | | | | | | | | | | | | | |
| | | | | | | | | | | | | | |
| | | | | | | | | | | | | | |
| | | | | | | | | | | | | | |
| | | | | | | | | | | | | | |
| | | | | | | | | | | | | | |
| | | | | | | | | | | | | | |
| | | | | | | | | | | | | | |
| | | | | | | | | | | | | | |
| | | | | | | | | | | | | | |

FIG. 17 WATER PUMP

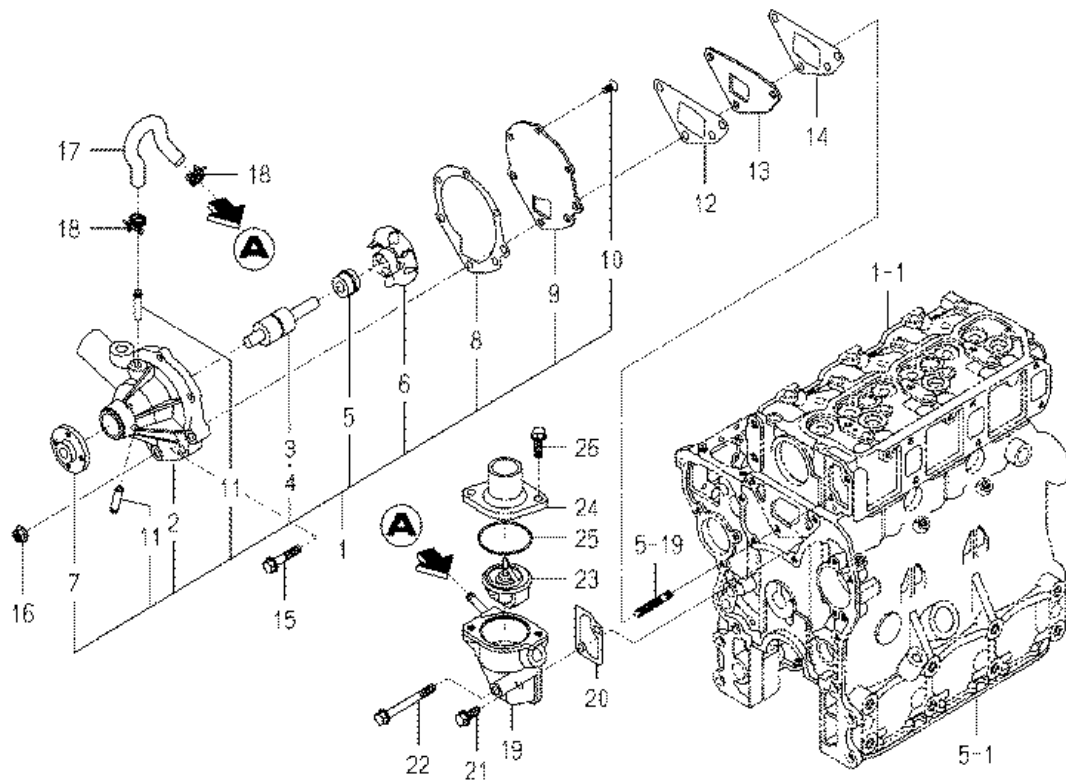

| KEY | Part Code | Description | S P C | Type of Model | | | | | | I T C | C O L | G R P | Remarks |
|-----|-----------------|----------------------|-------------|---------------|--|--|--|--|--|-------------|-------------|-------------|---------|
| | | | | E3CDG | | | | | | | | | |
| 1 | 6213-610-004-40 | WATERPUMP ASSY | * | 1 | | | | | | | | | |
| 2 | 6213-611-003-20 | BODY/WATERPUMP | * | 1 | | | | | | | | | |
| 3 | 6213-631-002-00 | BEARING/WATER PUMP | * | 1 | | | | | | | | | |
| 4 | 6213-631-005-00 | BEARING/WATERPUMP | * | 1 | | | | | | | | | |
| 5 | 6213-622-002-10 | SEAL SET/WATER PUMP | * | 1 | | | | | | | | | |
| 6 | 6213-621-003-00 | ROTOR/WATERPUMP | * | 1 | | | | | | | | | |
| 7 | 6213-642-002-00 | SEAL/WATER PUMPPULLE | * | 1 | | | | | | | | | |
| 8 | 6213-613-002-10 | GASKET | * | 1 | | | | | | | | | |
| 9 | 6213-612-004-00 | PLATE/WATER PUMP | * | 1 | | | | | | | | | |
| 10 | 6213-619-003-00 | SCREW/WATER PUMP | * | 3 | | | | | | | | | |
| 11 | 6213-619-002-00 | PIPE/WATER PUMP | * | 2 | | | | | | | | | |
| 12 | 6213-614-001-10 | GASKET,WATER PUMP | * | 1 | | | | | | | | | |
| 13 | 6213-619-007-10 | SPACER/WATERPUMP | * | 1 | | | | | | | | | |
| 14 | 6213-614-001-10 | GASKET,WATER PUMP | * | 1 | | | | | | | | | |
| 15 | 6209-046-020-00 | BOLT/FLAMGE | * | 2 | | | | | | | | | |
| 16 | 3817-401-001-00 | NUT/M08 | * | 1 | | | | | | | | | |
| 17 | 6213-729-013-10 | HOSE/RUBBER | * | 1 | | | | | | | | | |
| 18 | J061-210-015-00 | CLAMP/WIRE/10-15 | * | 2 | | | | | | | | | |
| 19 | 6213-716-001-50 | HOUSING/THERMOSTAT | * | 1 | | | | | | | | | |
| 20 | 6213-743-002-10 | GASKET/HOUSING | * | 1 | | | | | | | | | |
| 21 | 6209-046-017-00 | BOLT/FLAMGE | * | 1 | | | | | | | | | |
| 22 | 6209-046-025-00 | BOLT/FLAMGE | * | 1 | | | | | | | | | |
| 23 | 6513-770-022-10 | THERMOSTAT | * | 1 | | | | | | | | | |
| 24 | 6213-711-003-20 | PIPE,WATER OUTLET | * | 1 | | | | | | | | | |
| 25 | V723-102-005-50 | O-RING | * | 1 | | | | | | | | | |
| 26 | 6209-046-018-00 | BOLT/FLAMGE | * | 2 | | | | | | | | | |
| | | | | | | | | | | | | | |
| | | | | | | | | | | | | | |
| | | | | | | | | | | | | | |
| | | | | | | | | | | | | | |

FIG. 18 COOLING FAN

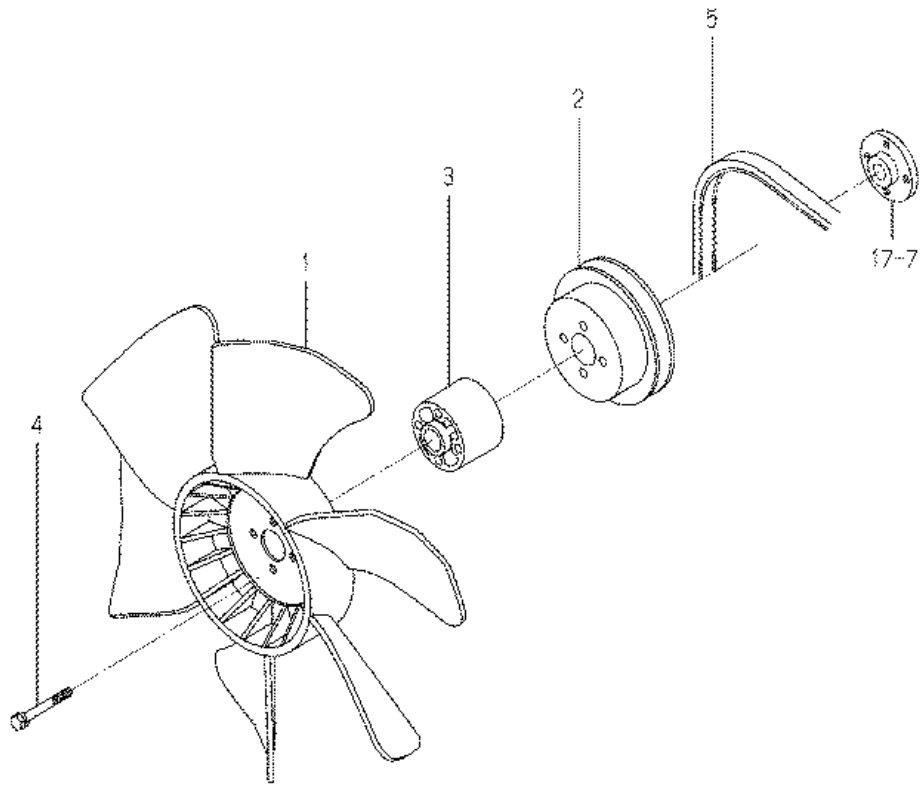

| KEY | Part Code | Description | S P C | Type of Model | | | | | I T C | C O L | G R P | Remarks |
|-----|-----------------|------------------|-------------|---------------|--|--|--|--|-------------|-------------|-------------|---------|
| | | | | E3C0G | | | | | | | | |
| 1 | 6213-660-012-00 | FAN/COOLING | * | 1 | | | | | | | | |
| 2 | 6213-641-022-10 | PULLEY/WATERPUMP | * | 1 | | | | | | | | |
| 3 | 6213-669-002-00 | SPACER,FAN/39 | * | 1 | | | | | | | | |
| 4 | 6209-030-041-00 | BOLT | * | 4 | | | | | | | | |
| 5 | 6213-671-030-00 | BELT/VR5A39.0 | * | 1 | | | | | | | | |
| | | | | | | | | | | | | |
| | | | | | | | | | | | | |
| | | | | | | | | | | | | |
| | | | | | | | | | | | | |
| | | | | | | | | | | | | |
| | | | | | | | | | | | | |
| | | | | | | | | | | | | |
| | | | | | | | | | | | | |
| | | | | | | | | | | | | |
| | | | | | | | | | | | | |
| | | | | | | | | | | | | |
| | | | | | | | | | | | | |
| | | | | | | | | | | | | |
| | | | | | | | | | | | | |
| | | | | | | | | | | | | |
| | | | | | | | | | | | | |
| | | | | | | | | | | | | |
| | | | | | | | | | | | | |
| | | | | | | | | | | | | |
| | | | | | | | | | | | | |
| | | | | | | | | | | | | |
| | | | | | | | | | | | | |
| | | | | | | | | | | | | |
| | | | | | | | | | | | | |
| | | | | | | | | | | | | |
| | | | | | | | | | | | | |
| | | | | | | | | | | | | |
| | | | | | | | | | | | | |
| | | | | | | | | | | | | |
| | | | | | | | | | | | | |
| | | | | | | | | | | | | |
| | | | | | | | | | | | | |
| | | | | | | | | | | | | |
| | | | | | | | | | | | | |
| | | | | | | | | | | | | |
| | | | | | | | | | | | | |
| | | | | | | | | | | | | |
| | | | | | | | | | | | | |
| | | | | | | | | | | | | |
| | | | | | | | | | | | | |
| | | | | | | | | | | | | |
| | | | | | | | | | | | | |
| | | | | | | | | | | | | |
| | | | | | | | | | | | | |
| | | | | | | | | | | | | |
| | | | | | | | | | | | | |
| | | | | | | | | | | | | |
| | | | | | | | | | | | | |
| | | | | | | | | | | | | |
| | | | | | | | | | | | | |

FIG. 19 INJECTION NOZZLE

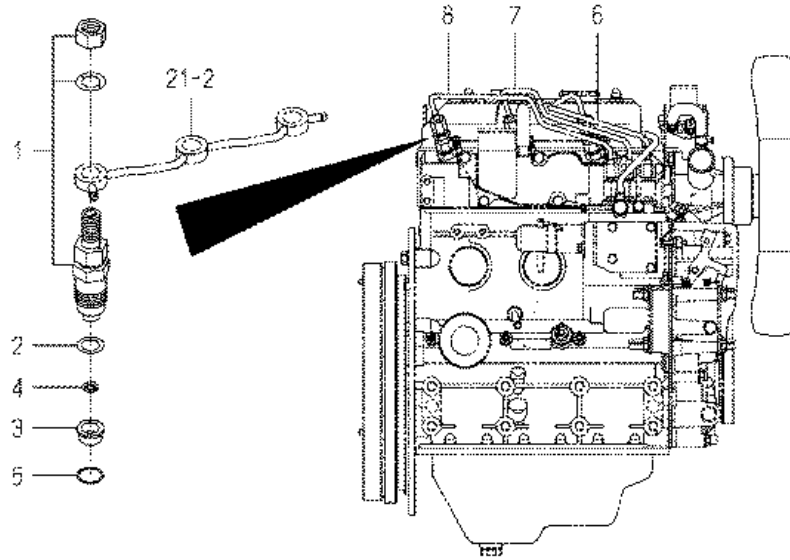

| KEY | Part Code | Description | S P C | Type of Model | | | | | I T C | C O L | G R P | Remarks |
|-----|-----------------|----------------------|-------------|---------------|--|--|--|--|-------------|-------------|-------------|---------|
| | | | | E3CDG | | | | | | | | |
| 1 | 6215-300-037-00 | INJECTIONNOZZLE ASSY | * | 3 | | | | | | | 027 | |
| 2 | 6215-315-002-00 | GASKET,NOZZLE | * | 3 | | | | | | | | |
| 3 | 6215-315-006-00 | HEATSHILD/NOZZLE | * | 3 | | | | | | | | |
| 4 | 6215-315-005-00 | WASHER/CORRUGATE | * | 3 | | | | | | | | |
| 5 | 6215-315-007-00 | GASKET | * | 3 | | | | | | | | |
| 6 | 6215-411-052-00 | PIPE/INJECTION ASSY | * | 1 | | | | | | | | |
| 7 | 6215-411-053-10 | PIPE/INJECTION ASSY | * | 1 | | | | | | | | |
| 8 | 6215-411-054-00 | PIPE/INJECTION ASSY | * | 1 | | | | | | | | |
| | | | | | | | | | | | | |
| | | | | | | | | | | | | |
| | | | | | | | | | | | | |
| | | | | | | | | | | | | |
| | | | | | | | | | | | | |
| | | | | | | | | | | | | |
| | | | | | | | | | | | | |
| | | | | | | | | | | | | |
| | | | | | | | | | | | | |
| | | | | | | | | | | | | |
| | | | | | | | | | | | | |
| | | | | | | | | | | | | |
| | | | | | | | | | | | | |
| | | | | | | | | | | | | |
| | | | | | | | | | | | | |
| | | | | | | | | | | | | |
| | | | | | | | | | | | | |
| | | | | | | | | | | | | |

FIG. 20 INJECTION PUMP

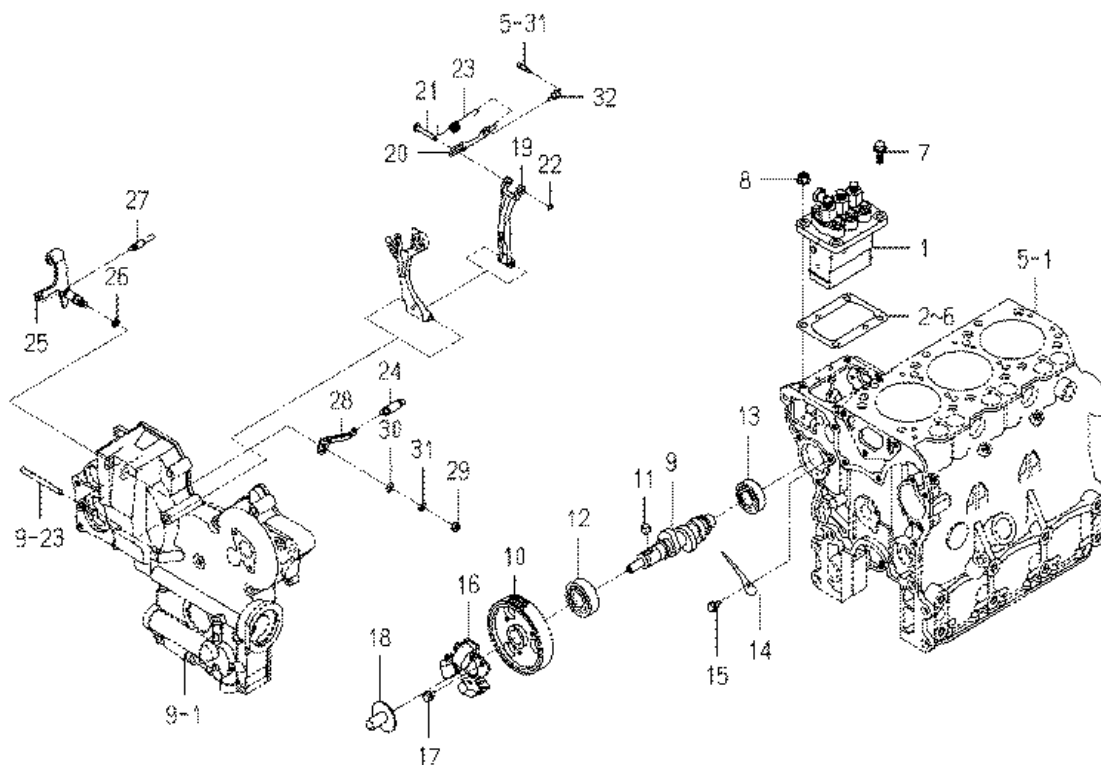

| KEY | Part Code | Description | S P C | Type of Model | | | | | I T C | C O L | G R P | Remarks |
|-----|-----------------|----------------------|-------------|---------------|--|--|--|--|-------------|-------------|-------------|---------|
| | | | | ESCDG | | | | | | | | |
| 1 | 6215-600-078-00 | INJECTIONPUMP ASSY | * | 1 | | | | | | | 028 | |
| 2 | 6219-752-006-00 | SHIM/INJECTION P/0.3 | * | 1 | | | | | | | | |
| 3 | 6219-752-007-00 | SHIM/INJECTION P/0.1 | * | 1 | | | | | | | | |
| 4 | 6219-752-008-00 | SHIM/INJECTION P/0.2 | * | 1 | | | | | | | | |
| 5 | 6219-752-009-00 | SHIM/INJECTION P/0.4 | * | 1 | | | | | | | | |
| 6 | 6219-752-010-00 | SHIM/INJECTION P/0.5 | * | 1 | | | | | | | | |
| 7 | 6209-046-017-00 | BOLT/FLAMGE | * | 2 | | | | | | | | |
| 8 | 3817-401-001-00 | NUT/M08 | * | 2 | | | | | | | | |
| 9 | 6215-621-018-10 | CAMSHAFT/INJPUMP | * | 1 | | | | | | | | |
| 10 | 6212-524-006-20 | GEAR/INJECTIONPUMP | * | 1 | | | | | | | | |
| 11 | 6209-730-005-00 | KEY/07X05X09 | * | 1 | | | | | | | | |
| 12 | V600-110-620-30 | BEARING,RB/6203 | * | 1 | | | | | | | | |
| 13 | V600-110-600-40 | BEARING,RB/6004 | * | 1 | | | | | | | | |
| 14 | 6212-535-009-00 | PLATE/THRUST/INJPUMP | * | 1 | | | | | | | | |
| 15 | 6901-910-612-00 | BOLT,SEMS/M6X12 | * | 1 | | | | | | | | |
| 16 | 6215-520-007-10 | FLYWEIGHT ASSY | * | 1 | | | | | | | | |
| 17 | 6209-030-043-00 | BOLT/M6X10 | * | 3 | | | | | | | | |
| 18 | 6215-526-001-10 | PIECE,THRUST | * | 1 | | | | | | | | |
| 19 | 6215-541-001-10 | ARM/FLOATING COMP | * | 1 | | | | | | | | |
| 20 | 6215-543-002-10 | RINK/CONTROL | * | 1 | | | | | | | | |
| 21 | 6215-542-006-00 | PIN,CONTROL | * | 1 | | | | | | | | |
| 22 | V710-140-004-00 | RING,SNAP/ 4 E | * | 1 | | | | | | | | |
| 23 | 6215-549-031-10 | SPRING/SETTING | * | 1 | | | | | | | | |
| 24 | 6215-531-006-10 | SPRING/GOVERNOR | * | 1 | | | | | | | | |
| 25 | 6215-541-014-10 | LEVER/CONTROL COMP | * | 1 | | | | | | | | |
| 26 | V720-101-900-80 | O-RING/P 8 | * | 1 | | | | | | | | |
| 27 | 6209-580-002-10 | SPRING,RETURN | * | 1 | | | | | | | | |
| 28 | 6215-549-007-10 | ARM/CONTROL | * | 1 | | | | | | | | |
| 29 | 6909-110-406-00 | NUT | * | 1 | | | | | | | | |
| 30 | V411-260-006-00 | WASHER / M6 | * | 1 | | | | | | | | |

FIG. 20 INJECTION PUMP

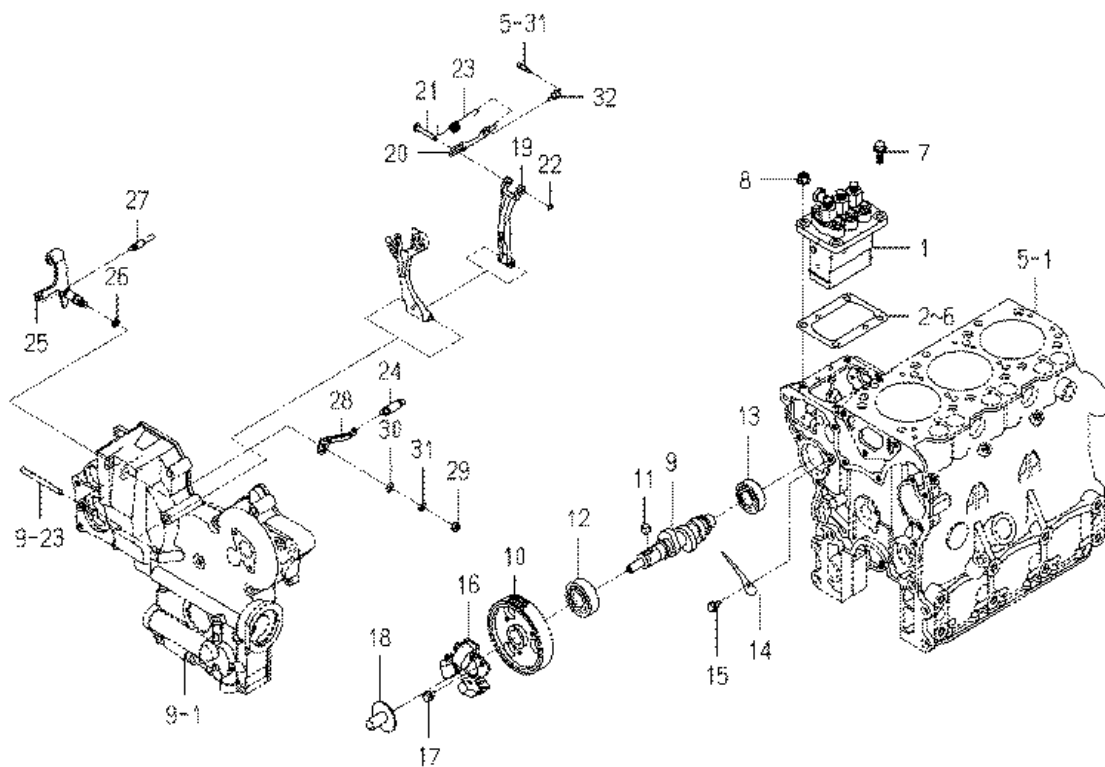

| KEY | Part Code | Description | S P C | Type of Model | | | | | I T C | C O L | G R P | Remarks |
|-----|-----------------|-----------------|-------------|---------------|--|--|--|--|-------------|-------------|-------------|---------|
| | | | | ESC DG | | | | | | | | |
| 31 | V401-160-006-00 | WASHER,SP/M 6 | * | 1 | | | | | | | | |
| 32 | 6215-549-039-00 | SPRING/STARTING | * | 1 | | | | | | | | |
| | | | | | | | | | | | | |
| | | | | | | | | | | | | |
| | | | | | | | | | | | | |
| | | | | | | | | | | | | |
| | | | | | | | | | | | | |
| | | | | | | | | | | | | |
| | | | | | | | | | | | | |
| | | | | | | | | | | | | |
| | | | | | | | | | | | | |
| | | | | | | | | | | | | |
| | | | | | | | | | | | | |
| | | | | | | | | | | | | |
| | | | | | | | | | | | | |
| | | | | | | | | | | | | |
| | | | | | | | | | | | | |
| | | | | | | | | | | | | |
| | | | | | | | | | | | | |
| | | | | | | | | | | | | |
| | | | | | | | | | | | | |
| | | | | | | | | | | | | |
| | | | | | | | | | | | | |
| | | | | | | | | | | | | |
| | | | | | | | | | | | | |
| | | | | | | | | | | | | |
| | | | | | | | | | | | | |
| | | | | | | | | | | | | |
| | | | | | | | | | | | | |
| | | | | | | | | | | | | |
| | | | | | | | | | | | | |
| | | | | | | | | | | | | |
| | | | | | | | | | | | | |
| | | | | | | | | | | | | |
| | | | | | | | | | | | | |
| | | | | | | | | | | | | |

FIG. 21 FUEL PIPE

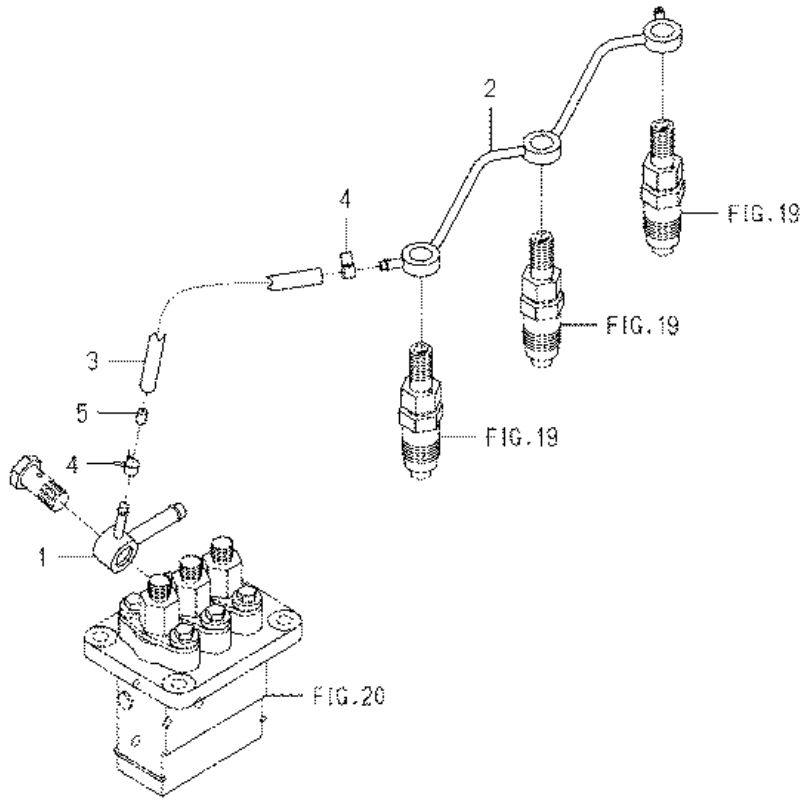

| KEY | Part Code | Description | S P C | Type of Model | | | | | | I T C | C O L | G R P | Remarks |
|-----|-----------------|-------------------|-------------|---------------|--|--|--|--|--|-------------|-------------|-------------|---------|
| | | | | E3CDG | | | | | | | | | |
| 1 | 6215-412-004-00 | CONNECTOR/FUEL | * | 1 | | | | | | | | | |
| 2 | 6215-411-080-10 | PIPE/FUEL | * | 1 | | | | | | | | | |
| 3 | 6209-360-011-00 | HOSE/RUBBER | * | 1 | | | | | | | | | |
| 4 | J062-076-082-00 | CLIP/HOSE/7.6-8.2 | * | 2 | | | | | | | | | |
| 5 | 3640-586-004-00 | RESISTANCE/1.0 | * | 1 | | | | | | | | | |
| | | | | | | | | | | | | | |
| | | | | | | | | | | | | | |
| | | | | | | | | | | | | | |
| | | | | | | | | | | | | | |
| | | | | | | | | | | | | | |
| | | | | | | | | | | | | | |
| | | | | | | | | | | | | | |
| | | | | | | | | | | | | | |
| | | | | | | | | | | | | | |
| | | | | | | | | | | | | | |
| | | | | | | | | | | | | | |
| | | | | | | | | | | | | | |
| | | | | | | | | | | | | | |
| | | | | | | | | | | | | | |
| | | | | | | | | | | | | | |
| | | | | | | | | | | | | | |
| | | | | | | | | | | | | | |
| | | | | | | | | | | | | | |
| | | | | | | | | | | | | | |
| | | | | | | | | | | | | | |

FIG. 22 ADAPTER

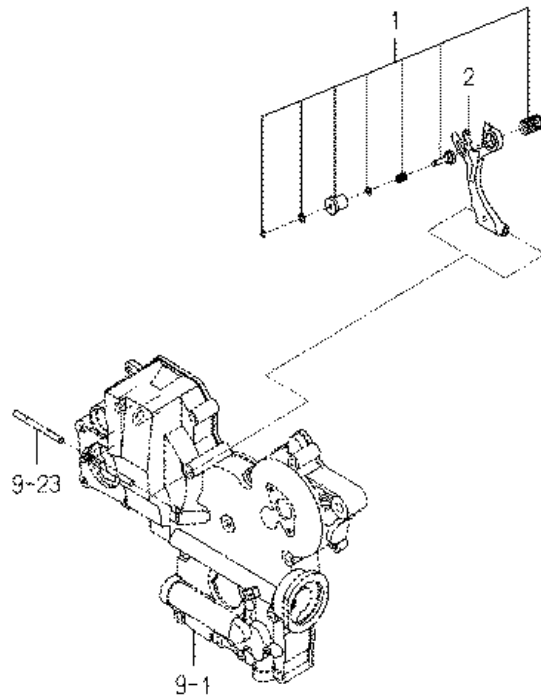

| KEY | Part Code | Description | S P C | Type of Model | | | | | | I T C | C O L | G R P | Remarks |
|-----|-----------------|----------------------|-------------|---------------|--|--|--|--|--|-------------|-------------|-------------|---------|
| | | | | E3CDG | | | | | | | | | |
| 1 | 6215-548-032-00 | ADAPTER/240X105 ASSY | * | 1 | | | | | | | | | |
| 2 | 6215-541-016-30 | ARM/TENSION | * | 1 | | | | | | | | | |
| | | | | | | | | | | | | | |
| | | | | | | | | | | | | | |
| | | | | | | | | | | | | | |
| | | | | | | | | | | | | | |
| | | | | | | | | | | | | | |
| | | | | | | | | | | | | | |
| | | | | | | | | | | | | | |
| | | | | | | | | | | | | | |
| | | | | | | | | | | | | | |
| | | | | | | | | | | | | | |
| | | | | | | | | | | | | | |
| | | | | | | | | | | | | | |
| | | | | | | | | | | | | | |
| | | | | | | | | | | | | | |
| | | | | | | | | | | | | | |
| | | | | | | | | | | | | | |
| | | | | | | | | | | | | | |
| | | | | | | | | | | | | | |
| | | | | | | | | | | | | | |
| | | | | | | | | | | | | | |
| | | | | | | | | | | | | | |
| | | | | | | | | | | | | | |
| | | | | | | | | | | | | | |
| | | | | | | | | | | | | | |
| | | | | | | | | | | | | | |
| | | | | | | | | | | | | | |
| | | | | | | | | | | | | | |

FIG. 23 ELECTRIC (1)

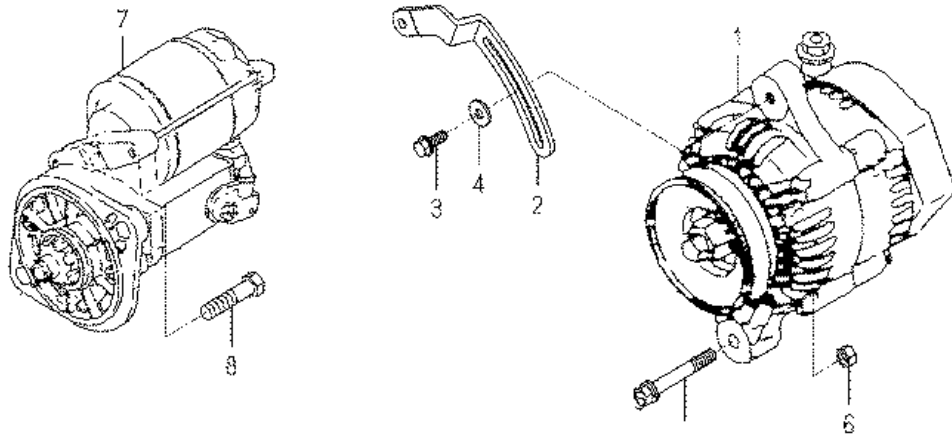

| KEY | Part Code | Description | S P C | Type of Model | | | | | I T C | C O L | G R P | Remarks |
|-----|-----------------|----------------|-------------|---------------|--|--|--|--|-------------|-------------|-------------|---------|
| | | | | E3CDG | | | | | | | | |
| 1 | 6281-200-022-00 | GENERATOR ASSY | * | 1 | | | | | | | | 030 |
| 2 | 6213-674-012-20 | PLATE/ADJUST | * | 1 | | | | | | | | |
| 3 | 6209-046-017-00 | BOLT/FLANGE | * | 1 | | | | | | | | |
| 4 | 1373-121-001-00 | WASHER/9X22X2 | * | 1 | | | | | | | | |
| 5 | 6209-046-058-00 | BOLT/FLANGE | * | 1 | | | | | | | | |
| 6 | 6909-110-410-00 | NUT/M10 | * | 1 | | | | | | | | |
| 7 | 6281-100-002-30 | STARTER ASSY | * | 1 | | | | | | | | 029 |
| 8 | 6901-931-240-00 | BOLT | * | 2 | | | | | | | | |
| | | | | | | | | | | | | |
| | | | | | | | | | | | | |
| | | | | | | | | | | | | |
| | | | | | | | | | | | | |
| | | | | | | | | | | | | |
| | | | | | | | | | | | | |
| | | | | | | | | | | | | |
| | | | | | | | | | | | | |
| | | | | | | | | | | | | |
| | | | | | | | | | | | | |
| | | | | | | | | | | | | |
| | | | | | | | | | | | | |
| | | | | | | | | | | | | |
| | | | | | | | | | | | | |
| | | | | | | | | | | | | |
| | | | | | | | | | | | | |
| | | | | | | | | | | | | |
| | | | | | | | | | | | | |
| | | | | | | | | | | | | |
| | | | | | | | | | | | | |
| | | | | | | | | | | | | |
| | | | | | | | | | | | | |
| | | | | | | | | | | | | |
| | | | | | | | | | | | | |
| | | | | | | | | | | | | |
| | | | | | | | | | | | | |
| | | | | | | | | | | | | |

FIG. 24 ELECTRIC (2)

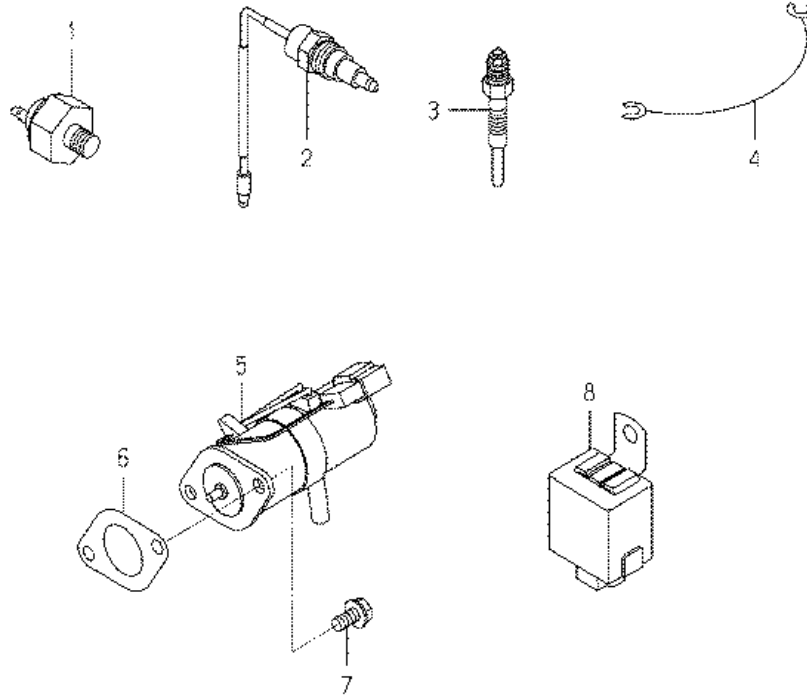

| KEY | Part Code | Description | SPC | Type of Model | | | | | | ITC | COL | GRP | Remarks |
|-----|-----------------|--------------------|-----|---------------|--|--|--|--|--|-----|-----|-----|---------|
| | | | | E3CDG | | | | | | | | | |
| 1 | 6281-971-001-10 | SWITCH/OILPRESSURE | * | 1 | | | | | | | | | |
| 2 | 6282-450-002-00 | SWITCH/OVERHEAT | * | 1 | | | | | | | | | |
| 3 | 6281-410-010-00 | GLOWPLUG | * | 3 | | | | | | | | | |
| 4 | 6219-732-012-00 | CONNECTOR/GLOWPLUG | * | 2 | | | | | | | | | |
| 5 | 6281-910-003-10 | SOLENOID | * | 1 | | | | | | | | | |
| 6 | 6209-630-002-10 | GASKET | * | 1 | | | | | | | | | |
| 7 | 6209-046-052-00 | BOLT/FLANGE | * | 2 | | | | | | | | | |
| 8 | 6281-920-001-00 | RELAY,SOLENOID | * | 1 | | | | | | | | | |
| | | | | | | | | | | | | | |
| | | | | | | | | | | | | | |
| | | | | | | | | | | | | | |
| | | | | | | | | | | | | | |
| | | | | | | | | | | | | | |
| | | | | | | | | | | | | | |
| | | | | | | | | | | | | | |
| | | | | | | | | | | | | | |
| | | | | | | | | | | | | | |
| | | | | | | | | | | | | | |
| | | | | | | | | | | | | | |
| | | | | | | | | | | | | | |
| | | | | | | | | | | | | | |
| | | | | | | | | | | | | | |
| | | | | | | | | | | | | | |
| | | | | | | | | | | | | | |
| | | | | | | | | | | | | | |
| | | | | | | | | | | | | | |
| | | | | | | | | | | | | | |
| | | | | | | | | | | | | | |
| | | | | | | | | | | | | | |
| | | | | | | | | | | | | | |
| | | | | | | | | | | | | | |
| | | | | | | | | | | | | | |
| | | | | | | | | | | | | | |
| | | | | | | | | | | | | | |
| | | | | | | | | | | | | | |
| | | | | | | | | | | | | | |
| | | | | | | | | | | | | | |
| | | | | | | | | | | | | | |
| | | | | | | | | | | | | | |
| | | | | | | | | | | | | | |
| | | | | | | | | | | | | | |
| | | | | | | | | | | | | | |
| | | | | | | | | | | | | | |
| | | | | | | | | | | | | | |
| | | | | | | | | | | | | | |
| | | | | | | | | | | | | | |
| | | | | | | | | | | | | | |
| | | | | | | | | | | | | | |
| | | | | | | | | | | | | | |
| | | | | | | | | | | | | | |
| | | | | | | | | | | | | | |
| | | | | | | | | | | | | | |
| | | | | | | | | | | | | | |
| | | | | | | | | | | | | | |
| | | | | | | | | | | | | | |
| | | | | | | | | | | | | | |

FIG. 25 LABEL

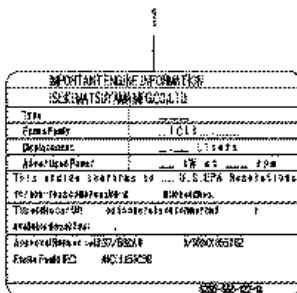

| KEY | Part Code | Description | S P C | Type of Model | | | | | | I T C | C O L | G R P | Remarks |
|-----|-----------------|-------------|-------------|---------------|--|--|--|--|--|-------------|-------------|-------------|---------|
| | | | | ESCDG | | | | | | | | | |
| 1 | 6285-885-122-10 | LABELSF330 | * | 1 | | | | | | | | | |
| | | | | | | | | | | | | | |
| | | | | | | | | | | | | | |
| | | | | | | | | | | | | | |
| | | | | | | | | | | | | | |
| | | | | | | | | | | | | | |
| | | | | | | | | | | | | | |
| | | | | | | | | | | | | | |
| | | | | | | | | | | | | | |
| | | | | | | | | | | | | | |
| | | | | | | | | | | | | | |
| | | | | | | | | | | | | | |
| | | | | | | | | | | | | | |
| | | | | | | | | | | | | | |
| | | | | | | | | | | | | | |
| | | | | | | | | | | | | | |
| | | | | | | | | | | | | | |
| | | | | | | | | | | | | | |
| | | | | | | | | | | | | | |
| | | | | | | | | | | | | | |
| | | | | | | | | | | | | | |
| | | | | | | | | | | | | | |
| | | | | | | | | | | | | | |
| | | | | | | | | | | | | | |
| | | | | | | | | | | | | | |
| | | | | | | | | | | | | | |
| | | | | | | | | | | | | | |
| | | | | | | | | | | | | | |

FIG. 26 REPAIR PARTS (OPTION)

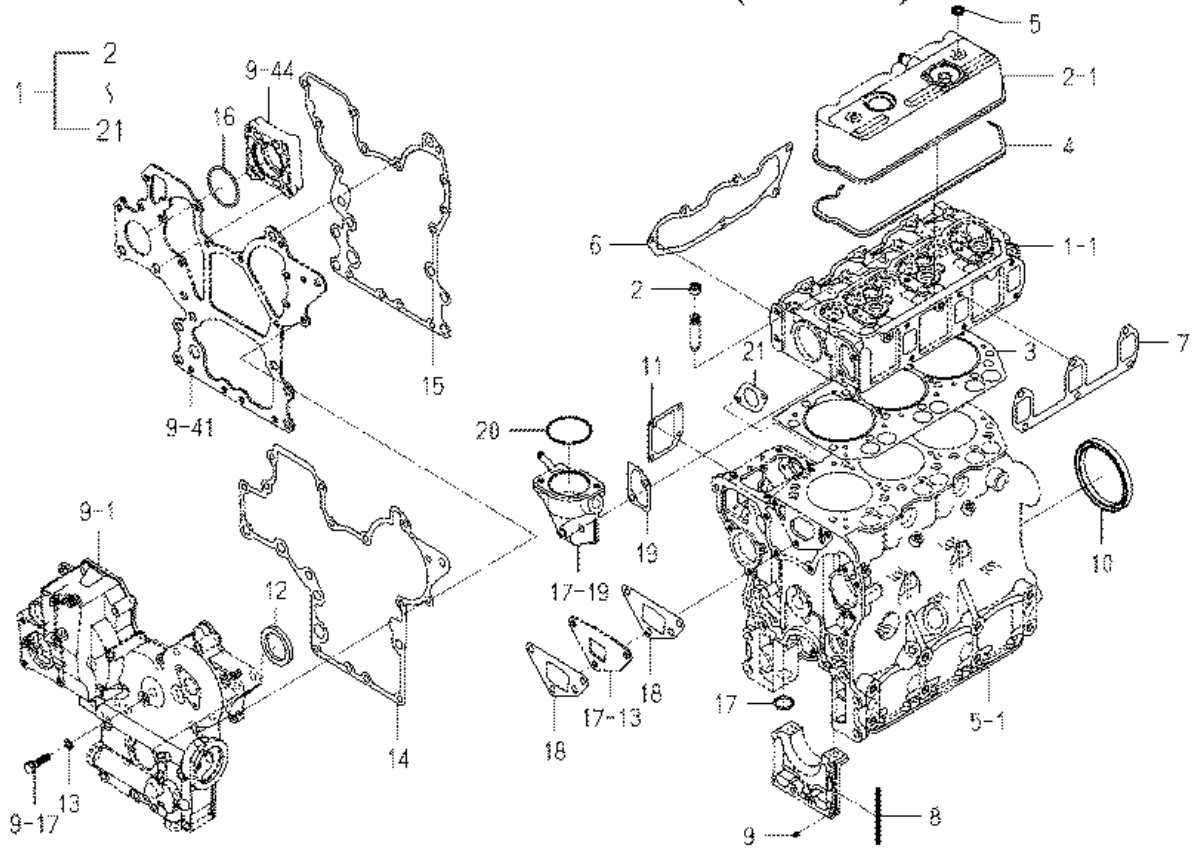

| KEY | Part Code | Description | S P C | Type of Model | | | | | | I T C | C O L | G R P | Remarks |
|-----|-----------------|----------------------|-------------|---------------|--|--|--|--|--|-------------|-------------|-------------|---------|
| | | | | E3CDG | | | | | | | | | |
| 1 | 6287-810-022-20 | REPAIR/ENGINE SET | T | 1 | | | | | | | | | |
| 2 | 6212-569-002-00 | SEAL,OIL | T | 6 | | | | | | | | | |
| 3 | 6211-141-023-50 | GASKET/CYLINDERHEAD | T | 1 | | | | | | | | | |
| 4 | 6211-173-005-00 | SEAL/CYL HEAD/UNDER | T | 1 | | | | | | | | | |
| 5 | 6209-572-002-00 | GASKET | T | 2 | | | | | | | | | |
| 6 | 6214-115-003-10 | GASKET/INLETMANIFOLD | T | 1 | | | | | | | | | |
| 7 | 6214-145-004-20 | GASKET/EXH MANIFOLD | T | 1 | | | | | | | | | |
| 8 | 6211-258-001-00 | SEAL, BEARING CAP | T | 4 | | | | | | | | | |
| 9 | 6211-258-002-00 | SEAL, BEARING CAP/7 | T | 2 | | | | | | | | | |
| 10 | 6209-625-003-20 | OILSEAL | T | 1 | | | | | | | | | |
| 11 | 6211-292-001-20 | GASKET/COVER | T | 1 | | | | | | | | | |
| 12 | 6209-625-002-00 | SEAL,OIL | T | 1 | | | | | | | | | |
| 13 | 6209-500-003-00 | WASHER/08X14X01 | T | 2 | | | | | | | | | |
| 14 | 6211-312-005-10 | GASKET/GEARCASE | T | 1 | | | | | | | | | |
| 15 | 6211-312-006-10 | GASKET/PLATE | T | 1 | | | | | | | | | |
| 16 | V723-102-005-00 | O-RING 1A S50 | T | 1 | | | | | | | | | |
| 17 | V720-103-502-20 | O-RING/P22 | T | 1 | | | | | | | | | |
| 18 | 6213-614-001-10 | GASKET,WATER PUMP | T | 2 | | | | | | | | | |
| 19 | 6213-743-002-10 | GASKET/HOUSING | T | 1 | | | | | | | | | |
| 20 | V723-102-005-50 | O-RING | T | 1 | | | | | | | | | |
| 21 | 6209-630-002-10 | GASKET | T | 1 | | | | | | | | | |
| | | | | | | | | | | | | | |
| | | | | | | | | | | | | | |
| | | | | | | | | | | | | | |
| | | | | | | | | | | | | | |
| | | | | | | | | | | | | | |
| | | | | | | | | | | | | | |
| | | | | | | | | | | | | | |
| | | | | | | | | | | | | | |
| | | | | | | | | | | | | | |
| | | | | | | | | | | | | | |
| | | | | | | | | | | | | | |
| | | | | | | | | | | | | | |
| | | | | | | | | | | | | | |
| | | | | | | | | | | | | | |
| | | | | | | | | | | | | | |
| | | | | | | | | | | | | | |
| | | | | | | | | | | | | | |

**FIG. 27 COMPONENT PARTS
FOR 6215-300-037-00 ON Fig.19**

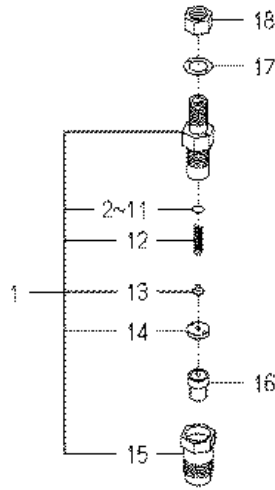

| KEY | Part Code | Description | S P C | Type of Model | | | | | | I T C | C O L | G R P | Remarks |
|-----|-----------------|---------------------|-------------|---------------|--|--|--|--|--|-------------|-------------|-------------|---------|
| | | | | E3CDG | | | | | | | | | |
| 1 | 6215-330-022-00 | HOLDER/NOZZLE ASSY | * | 3 | | | | | | | | | |
| 2 | 6215-345-044-00 | SHIM/0.10 | * | 3 | | | | | | | | | |
| 3 | 6215-345-045-00 | SHIM/0.20 | * | 3 | | | | | | | | | |
| 4 | 6215-345-046-00 | SHIM/0.30 | * | 3 | | | | | | | | | |
| 5 | 6215-345-047-00 | SHIM/0.40 | * | 3 | | | | | | | | | |
| 6 | 6215-345-048-00 | SHIM/0.50 | * | 3 | | | | | | | | | |
| 7 | 6215-345-049-00 | SHIM/0.52 | * | 3 | | | | | | | | | |
| 8 | 6215-345-050-00 | SHIM/0.54 | * | 3 | | | | | | | | | |
| 9 | 6215-345-051-00 | SHIM/0.56 | * | 3 | | | | | | | | | |
| 10 | 6215-345-052-00 | SHIM/0.58 | * | 3 | | | | | | | | | |
| 11 | 6215-345-053-00 | SHIM/0.80 | * | 3 | | | | | | | | | |
| 12 | 6215-343-002-00 | SPRING,NOZZLE | * | 3 | | | | | | | | | |
| 13 | 6215-342-002-00 | SEAT,SPRING | * | 3 | | | | | | | | | |
| 14 | 6215-339-004-00 | SPACER | * | 3 | | | | | | | | | |
| 15 | 6215-332-006-00 | NUT/NOZZLERETAINING | * | 3 | | | | | | | | | |
| 16 | 6215-311-005-00 | NOZZLE | * | 3 | | | | | | | | | |
| 17 | 6215-359-003-00 | GASKET | * | 3 | | | | | | | | | |
| 18 | 6215-359-004-00 | NUT | * | 3 | | | | | | | | | |
| | | | | | | | | | | | | | |
| | | | | | | | | | | | | | |
| | | | | | | | | | | | | | |
| | | | | | | | | | | | | | |
| | | | | | | | | | | | | | |
| | | | | | | | | | | | | | |
| | | | | | | | | | | | | | |
| | | | | | | | | | | | | | |
| | | | | | | | | | | | | | |
| | | | | | | | | | | | | | |
| | | | | | | | | | | | | | |
| | | | | | | | | | | | | | |
| | | | | | | | | | | | | | |
| | | | | | | | | | | | | | |
| | | | | | | | | | | | | | |

**FIG. 28 COMPONENT PARTS
 FOR 6215-600-078-00 ON Fig.20**

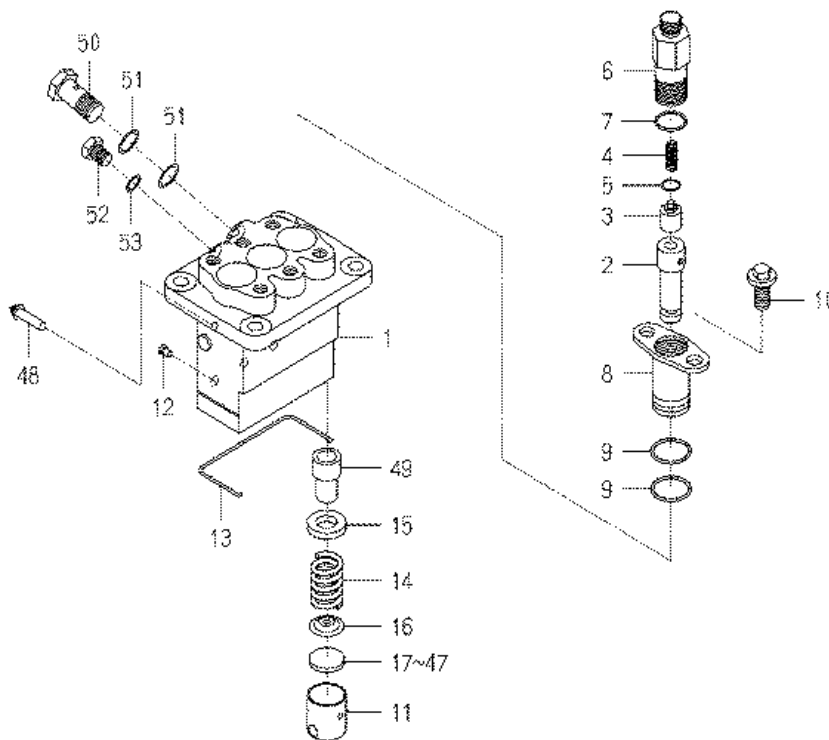

| KEY | Part Code | Description | S P C | Type of Model | | | | | | I T C | C O L | G R P | Remarks |
|-----|-----------------|----------------------|-------------|---------------|--|--|--|--|--|-------------|-------------|-------------|---------|
| | | | | E3CDG | | | | | | | | | |
| 1 | 6215-611-015-00 | HOUSING/PUMP | * | 1 | | | | | | | | | |
| 2 | 6215-631-008-00 | PLUNGER ASSY | * | 3 | | | | | | | | | |
| 3 | 6215-641-002-00 | VALVE,DELIVERY | * | 3 | | | | | | | | | |
| 4 | 6215-643-005-00 | SPRING/DELIVERYVALVE | * | 3 | | | | | | | | | |
| 5 | 6215-649-008-00 | GASKET | * | 3 | | | | | | | | | |
| 6 | 6215-644-006-00 | HOLDER/DELIVERYVALVE | * | 3 | | | | | | | | | |
| 7 | 6215-649-009-00 | O-RING | * | 3 | | | | | | | | | |
| 8 | 6215-635-004-00 | SLEEVEFLANGE | * | 3 | | | | | | | | | |
| 9 | 6215-649-010-00 | ORING | * | 6 | | | | | | | | | |
| 10 | 6215-649-011-00 | BOLT | * | 6 | | | | | | | | | |
| 11 | 6215-622-003-00 | TAPPET | * | 3 | | | | | | | | | |
| 12 | 6215-629-017-00 | PIN | * | 3 | | | | | | | | | |
| 13 | 6215-629-035-00 | SNAPRING | * | 1 | | | | | | | | | |
| 14 | 6215-634-003-00 | SPRING/PLUNGER | * | 3 | | | | | | | | | |
| 15 | 6215-639-008-00 | SPRINGSEAT | * | 3 | | | | | | | | | |
| 16 | 6215-639-009-00 | SPRINGSEAT | * | 3 | | | | | | | | | |
| 17 | 6215-629-060-00 | PLATE/T=2.60 | * | 1 | | | | | | | | | |
| 18 | 6215-629-061-00 | PLATE/T=2.65 | * | 1 | | | | | | | | | |
| 19 | 6215-629-062-00 | PLATE/T=2.70 | * | 1 | | | | | | | | | |
| 20 | 6215-629-063-00 | PLATE/T=2.75 | * | 1 | | | | | | | | | |
| 21 | 6215-629-064-00 | PLATE/T=2.80 | * | 1 | | | | | | | | | |
| 22 | 6215-629-065-00 | PLATE/T=2.85 | * | 1 | | | | | | | | | |
| 23 | 6215-629-066-00 | PLATE/T=2.90 | * | 1 | | | | | | | | | |
| 24 | 6215-629-067-00 | PLATE/T=2.95 | * | 1 | | | | | | | | | |
| 25 | 6215-629-036-00 | PLATE/T=3.00 | * | 1 | | | | | | | | | |
| 26 | 6215-629-037-00 | PLATE/T=3.05 | * | 1 | | | | | | | | | |
| 27 | 6215-629-038-00 | PLATE/T=3.10 | * | 1 | | | | | | | | | |
| 28 | 6215-629-039-00 | PLATE/T=3.15 | * | 1 | | | | | | | | | |
| 29 | 6215-629-040-00 | PLATE/T=3.20 | * | 1 | | | | | | | | | |
| 30 | 6215-629-041-00 | PLATE/T=3.25 | * | 1 | | | | | | | | | |

