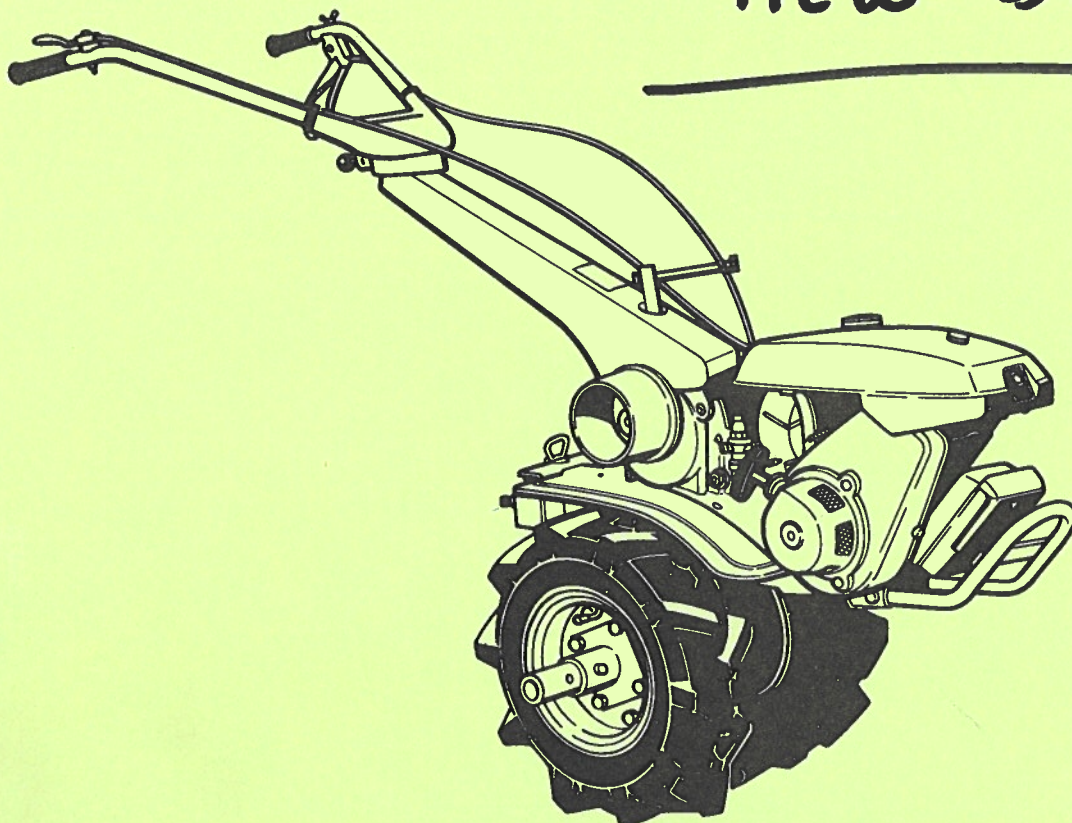


NEW 03/6/83

---



PARTS CATALOGUE  
ISEKI POWER TILLER

# KS 280





1979-80 FISH AND WILDLIFE CENSUS REPORT

WATERFOWL AND GAME BIRDS

Species	Count
Canada Goose	15
Ring-necked Pheasant	25
Partridge	10
Quail	5
Other	2

The waterfowl and game birds were counted on the following dates: 15th, 20th, 25th, and 30th September 1979.

The total number of birds counted was 57. The majority of the birds were Canada Geese and Ring-necked Pheasants.

The birds were counted in the following areas: 150, 200, 250, and 300.

The birds were counted in the following areas: 150, 200, 250, and 300.

The birds were counted in the following areas: 150, 200, 250, and 300.

The birds were counted in the following areas: 150, 200, 250, and 300.

The birds were counted in the following areas: 150, 200, 250, and 300.

The birds were counted in the following areas: 150, 200, 250, and 300.

The birds were counted in the following areas: 150, 200, 250, and 300.

E. Remarks: Additional information if any.

Explanation of symbols:

E. Remarques: On trouvera ici des observations utiles s'il y a lieu.

Explications des symboles:

- "★" indique des pièces fabriquées sur commande.
- "△" indique des pièces qui ne sont pas vendues séparément.

INDICATIONS POUR LA COMMANDE DES PIÈCES:

Le N° de code, la désignation de la pièce, et la quantité voulue devront être indiqués clairement à la machine à écrire sans erreur ou omission sur la feuille de commande.

On notera en particulier que des numéros de code erronés enregistrés à la commande par ordinateur risquent d'entraîner des erreurs à la fourniture des pièces.

NO	NUMBER	ORIGINAL WORDS
		NEEDLE ROLLER
		PITCH
		PRESSURE
		POWER TAKE OFF
		REAR
		RADIAL BALL
		RIGHT HAND
		SPRING
		TEETH
		THRUST BALL
		UPPER

## CONTENTS

		PAGE
ENGINE (4-cycle type)	.....	1~10
ENGINE (2-cycle type)		
Fig. 1	CRANK CASE AND CYLINDER ..... Carter moteur	13
Fig. 2	CRANK SHAFT AND CAM SHAFT ..... Vilebrequin	15
Fig. 3	SPIRAL CASE AND GOVERNOR ..... Volute & regulateur	17
Fig. 4	AIR CLEANER AND MUFFLER ..... Filtre a air et silencieux	19
Fig. 5	CARBURETOR ..... Carburateur	20
Fig. 6	FLYWHEEL AND MAGNET ..... Volant magnetique	21
Fig. 7	TOOLS ..... Outils	23
CHASSIS		
Fig. 8	FRAME ..... Longeron	25
Fig. 9	TRANSMISSION GEAR CASE ..... Boitier de reducteur	27
Fig. 10	TRANSMISSION GEAR ..... Reducteur	29
Fig. 11	SHIFTER ..... Fourchettes	31
Fig. 12	HANDLE FRAME ..... Mancherons	33
Fig. 13	CONTROL SYSTEM ..... Commandes	35
Fig. 14	FRONT COVER AND FUEL SYSTEM (2-cycle type)..... Reservoir & capot	37
Fig. 14A	BONNET (4-cycle type)..... Capot	39
Fig. 15	BELT DRIVE (2-cycle type)..... Systeme d'entrainement	41

		PAGE
Fig. 15A	BELT DRIVE (4-cycle type) ..... Système d'entraînement	43
Fig. 16	WHEEL ..... Roues	45
Fig. 17	WHEEL PIPE ..... Tube rallonge	47
Fig. 18	RECOIL STARTER ..... Lanceur	49
Fig. 19	POWER TAKE OFF ..... Poulie de prise de force	51
Fig. 20	ROTARY BELT DRIVE ..... Courvoie intermediaire	53
Fig. 21	ROTARY CHAIN CASE ..... Transmission de rotobineuse	55
Fig. 22	ROTARY SHIFTER ..... Embrayage de rotobineuse	57
Fig. 23	ROTARY PIPE ..... Fraise	59
Fig. 24	ROTARY FRAME ..... Enveloppe de rotobineuses	61
Fig. 25	TOOLS ..... Outils	63

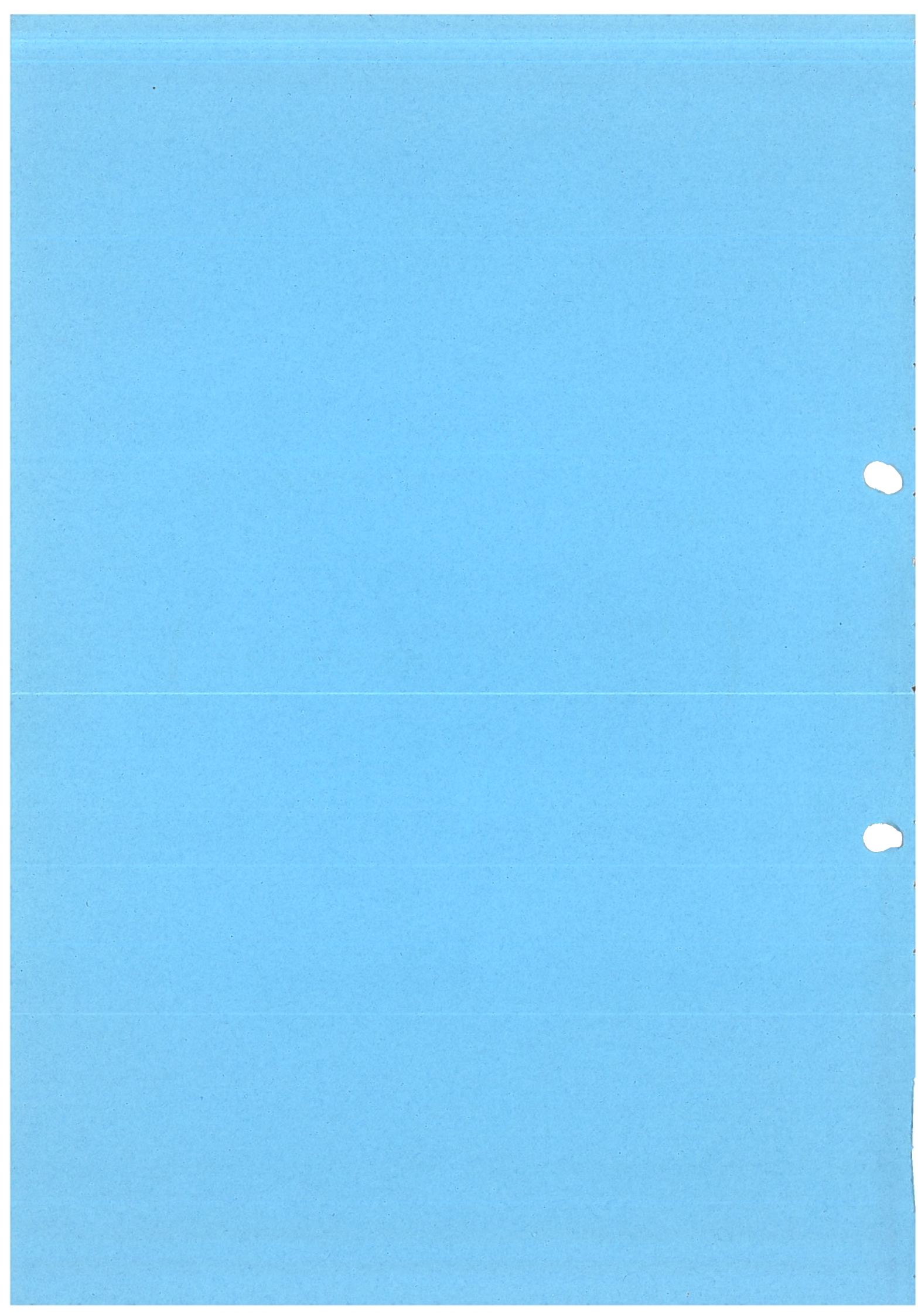
**ENGINE**

**FA130G-12**

**Moteur**

**( for  
pour**

**KS280-4E**





CONTENTS  
TABLE DES MATIERES

ENGINE  
Moteur

Fig.	E-1	ENGINE (FA130G-12 314419A) .....	1
		Moteur	
Fig.	A-1	AIR CLEANER .....	7
		Filtre a air	
Fig.	R-1	RECOIL STARTER .....	8
		Lanceur	
Fig.	C-1	CARBURETOR .....	9
		Carburateur	

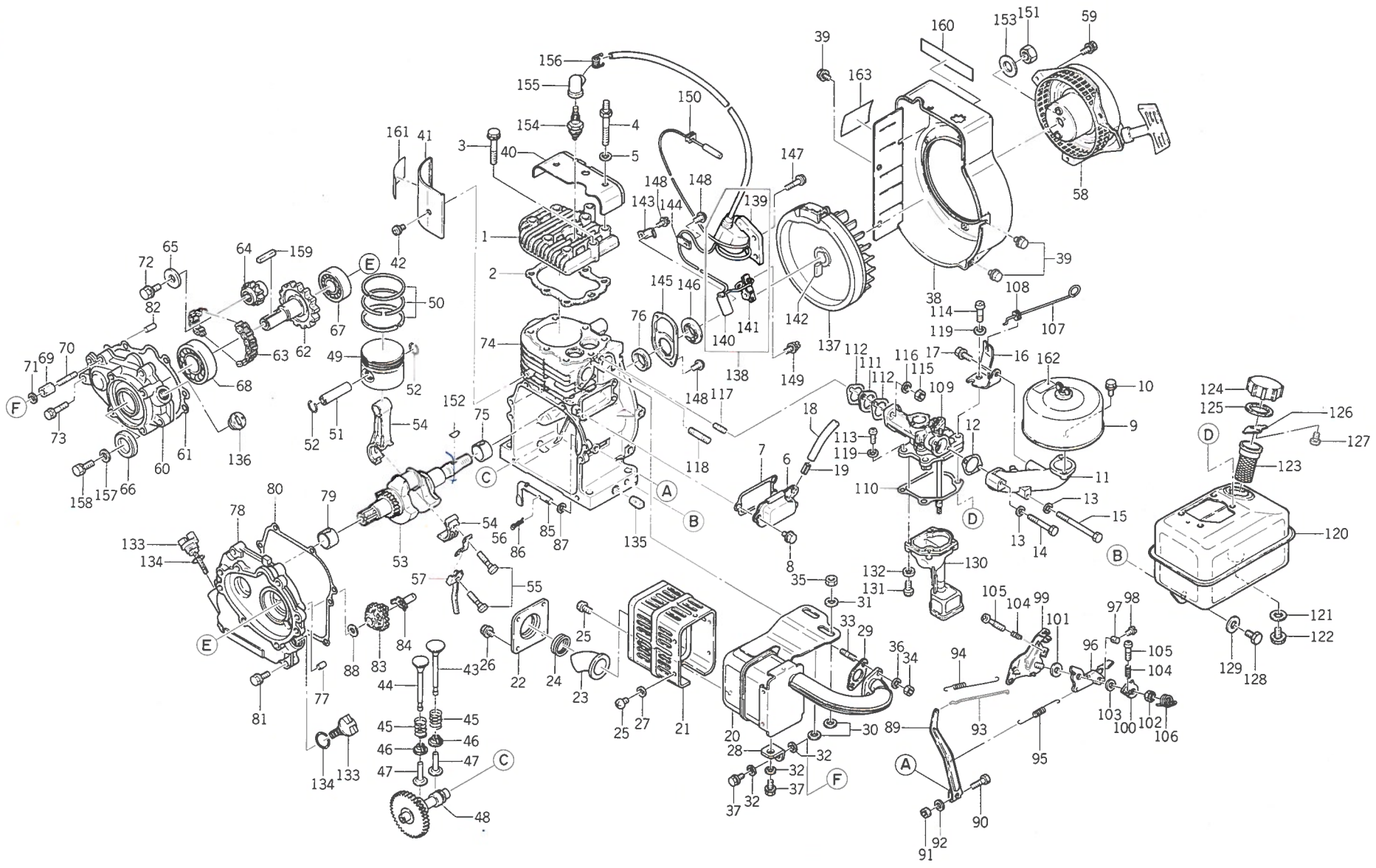
NOTE)

*\* Marked parts in the column remarks, are not always in stock, requiring considerable time for their delivery.*

NOTA)

*\* Les pièces marquées dans la colonne des remarques, ne sont pas toujours disponibles en stock, et demandent beaucoup de temps avant de pouvoir être livrées.*

Fig. E-1 ENGINE (FA130G-12 314419A)  
Moteur



Ref. No. Réf. No.	Part No. Pièces No.	Description Désignation	Q'ty Quant.	Remarks Remarques	
1	5144-011-111A-X	HEAD, CLY. Culasse	1	314401-1111A	
2	5144-011-121B-X	GASKET, HEAD Joint	1	314401-1121B	
3	5151-G08-50XX-X	BOLT/M8×50 Vis	2	151G0850	
4	5144-061-181A-X	BOLT Vis	5	314406-1181A	
5	5410-B08-00XX-X	WASHER, PL/M8 Rondelle	5	410B0800	
6	5144-011-231A-X	COVER, INSPECTION Porte de vis ite	1	314401-1231A	
7	5144-011-232A-X	GASKET Joint	1	314401-1232A	
8	5186-B06-12XX-X	BOLT/M6×12 Vis	3	186B0612	
9	5144-191-310A-X	AIR CLEANER ASSY Filtre a air	1	314419-1310A	See Fig. A-1 Voir Fig. A-1
10	5180-B06-14XX-X	BOLT/M6×14 Vis	2	180B0614	
11	5144-191-331A-X	PIPE, INLET Pipe d'admission	1	314419-1331A	
12	5144-011-332A-X	GASKET Joint	1	314401-1332A	
13	5164-421-3810-0	WASHER Rondelle	2	316442-1381-00	
14	5112-B05-35XX-X	BOLT/M5×35 Vis	1	112B0535	
15	5112-B05-60XX-X	BOLT/M5×60 Vis	1	112B0560	
16	5144-191-351A-X	STAY, AIR CLEANER Support	1	314419-1351A	
17	5186-B06-12XX-X	BOLT/M6×12 Vis	1	186B0612	
18	5702-A07-1000-X	TUBE, RUBBER/ø=160mm Tuyau	1	702A071000	
19	5144-011-341A-X	PIPE Raccord	1	314401-1341A	
20	5144-191-400A-X	MUFFLER ASSY Silencieux	1	314419-1400A	
21	5144-191-431A-X	•COVER, MUFFLER Protecteur	1	314419-1431A	
22	5144-061-447A-X	•PLATE Flasque	1	314406-1447A	
23	5144-061-449A-X	•PIPE, TAIL Tube d'échappement	1	314406-1449A	
24	5144-061-455A-X	•SPRING Ressort	1	314406-1455A	
25	5144-053-091B-X	•SCREW Vis	9	314405-3091B	
26	5235-B05-08XX-X	•SCREW/M5×8 Vis	4	235B0508	
27	5410-B04-00XX-X	•WASHER, PL/M4 Rondelle	5	410B0400	
28	5144-191-436A-X	BRACKET Support	1	314419-1436A	
29	5144-961-442A-X	GASKET Joint	1	314496-1442A	
30	5132-522-3830-0	WASHER Rondelle	2	313252-2383-00	
31	5144-016-681A-X	WASHER Rondelle	1	314401-6681A	
32	5117-023-5910-0	WASHER Rondelle	3	311702-3591-00	
33	5171-G06-16XX-X	STUD Goujon	2	171G0616	
34	5311-B06-00XX-X	NUT/M6 Ecrou	2	311B0600	
35	5311-B08-00AX-X	NUT/M8 Ecrou	1	311B0800A	
36	5410-B06-00XX-X	WASHER, PL/M6 Rondelle	2	410B0600	
37	5156-G06-14XX-X	BOLT/M6×14 Vis	2	156G0614	
38	5144-191-611A-X	CASE, SPIRAL Volute	1	314419-1611A	
39	5186-B06-10XX-X	BOLT/M6×10 Vis	5	186B0610	

Ref. No. Réf. No.	Part No. Pièces No.	Description Désignation	Q'ty Quant.	Remarks Remarques
40	5144-961-631A-X	COVER, CYL. HEAD Couvre culasse	1	314496-1631A
41	5144-011-632A-X	COVER, CLY. Couvre culasse	1	314401-1632A
42	5241-B05-10XX-X	SCREW/M5x10 Vis	1	241B0510
43	5144-002-111A-X	VALVE, INLET Soupape adm.	1	314400-2111A
44	5144-012-112A-X	VALVE, EXHAUST Soupape ech.	1	314401-2112A
45	5144-012-113A-X	SPRING Ressort	2	314401-2113A
46	5144-012-116B-X	RETAINER Plaquette frein	2	314401-2116B
47	5144-012-211A-X	TAPPET Poussoir	2	314401-2211A
48	5144-012-311C-X	GEAR, CAM A. C.	1	314401-2311C
49	5144-013-111A-X	PISTON Piston	1	314401-3111A
50	5144-013-010A-X	PISTON RING SET Segmentation	1	314401-3010A
51	5144-013-121A-X	PIN, PISTON Axe de piston	1	314401-3121A
52	5144-013-122A-X	RING, SNAP Collet d'axe	2	314401-3122A
53	5144-153-211A-X	SHAFT, CRANK Vile brequin	1	314415-3211A
54	5144-013-240A-X	CONN. ROD ASSY Bielle	1	314401-3240A
55	5144-013-245A-X	•BOLT, CONN. ROD Vis	2	314401-3245A
56	5144-013-248A-X	WASHER, LOCK Rondelle	1	314401-3248A
57	5144-013-249C-X	ARM, SPLASHER Bras de manivelle	1	314401-3249C
58	5144-193-430A-X	RECOIL STARTER ASSY Lanceur complet	1	314419-3430A
59	5187-B06-10XX-X	BOLT/M6x10 Vis	3	187B0610
60	5144-153-511A-X	CASE, REDUCER Boitier de reducteur	1	314415-3511A
61	5144-153-515A-X	GASKET Joint	1	314415-3515A
62	5144-193-521A-X	SHAFT, DRIVE Arbre d'entraînement	1	314419-3521A
63	5144-153-525A-X	CHAIN Chaîne	1	314415-3525A
64	5144-153-671A-X	SPROCKET Pignon a chaîne	1	314415-3671A
65	5132-522-3830-0	WASHER Rondelle	1	313252-2383-00
66	5164-704-2310-0	SEAL, OIL Bague d'étancheite	1	316470-4231-00
67	5601-A62-04XX-X	BEARING, RB/6204 Roulement	1	601A6204
68	5601-A63-05XX-X	BEARING, RB/6305 Roulement	1	601A6305
69	5121-131-4810-0	NUT Ecrou	1	312113-1481-00
70	5171-G06-30XX-X	STUD Coujon	1	171G0630
71	5411-B06-00XX-X	WASHER, PL/M6 Rondelle	1	411B0600
72	5181-B08-16XX-X	BOLT/M8x16 Vis	1	181B0816
73	5186-B06-30XX-X	BOLT/M6x30 Vis	5	186B0630
74	5144-014-110A-X	CRANK CASE ASSY Carter	1	314401-4110A
75	5144-014-211A-X	•BEARING, PLAIN Coussinet de palier	1	314401-4211A
76	5144-014-231B-X	SEAL, OIL Bague d'étancheite	1	314401-4231B
77	5551-A06-12XX-X	PIN, DOWEL Goupille elastique	2	551A0612
78	5144-154-120A-X	SIDE BASE ASSY Flasque	1	314415-4120A

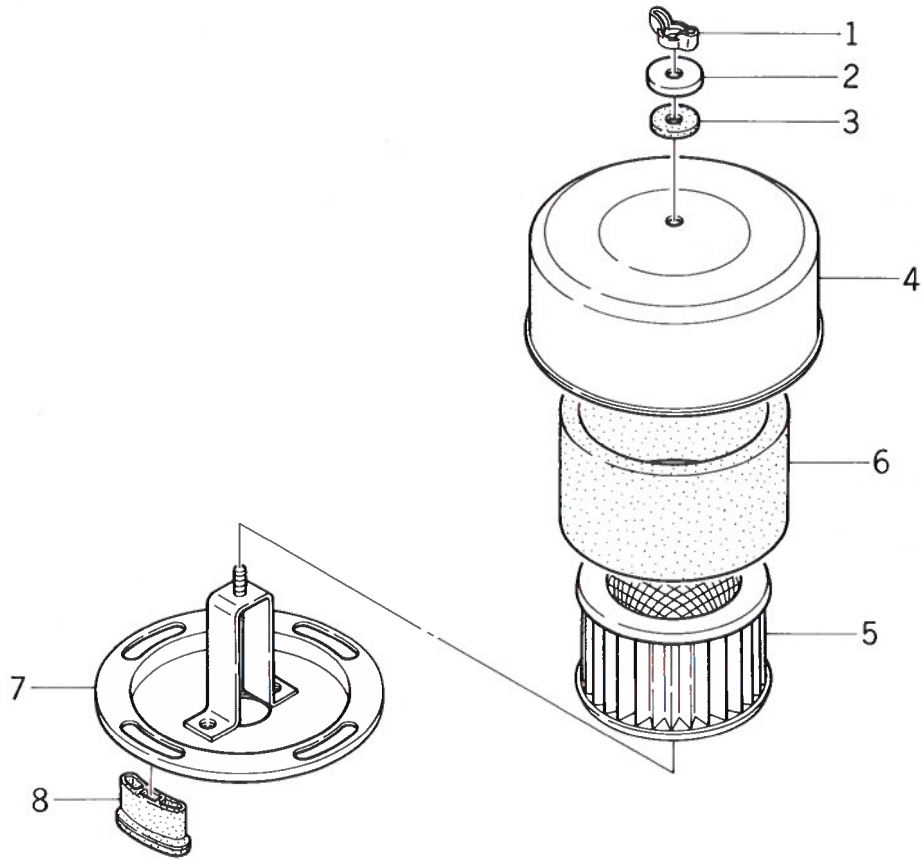
See Fig. R-1  
Voir Fig. R-1

Ref. No. Réf. No.	Part No. Pièces No.	Description Désignation	Q'ty Quant.	Remarks Remarques	
79	5144-014-211A-X	●BEARING, PLAIN Coussinet de palier	1	314401-4211A	
80	5144-014-124A-X	GASKET Joint	1	314401-4124A	
81	5186-B06-30XX-X	BOLT/M6×30 Vis	6	186B0630	
82	5551-A06-12XX-X	PIN, DOWEL Goupille elastque	2	551A0612	
83	5144-015-110A-X	GOVERNOR ASSY Regulateur	1	314401-5110A	
84	5144-015-121A-X	SLEEVE, GOVERNOR Guidage d'entraineur	1	314401-5121A	
85	5144-015-122C-X	ARM, GOVERNOR Bras de reglage	1	314401-5122C	
86	5554-A06-00XX-X	PIN, SNAP Attache beta	1	554A0600	
87	5410-B06-00XX-X	WASHER, PL/M6 Rondelle	1	410B0600	
88	5144-015-135A-X	WASHER Rondelle	1	314401-5135A	
89	5144-015-210C-X	GOVERNOR ARM ASSY Levier de reglage	1	314401-5210C	
90	5112-B06-25XX-X	●BOLT/M6×25 Vis	1	112B0625	
91	5311-B06-00XX-X	●NUT/M6 Ecrou	1	311B0600	
92	5411-B06-00XX-X	●WASHER, PL/M6 Rondelle	1	411B0600	
93	5144-015-231B-X	LINK, GOVERNOR Timonerie de regulateur	1	314401-5231B	
94	5136-505-2320-0	SPRING, LINK Ressort de timonerie	1	313650-5232-00	
95	5144-015-314B-X	SPRING Ressort	1	314401-5314B	
96	5144-015-311D-X	LEVER, CONTROL Levier de commande	1	314401-5311D	
97	5144-965-312A-X	NUT Ecrou	1	314496-5312A	
98	5214-B04-08XX-X	SCREW/M4×8 Vis	1	214B0408	
99	5144-015-335A-X	BRACKET Support	1	314401-5335A	
100	5144-015-337B-X	BRACKET Support	1	314401-5337B	
101	5144-015-383A-X	WASHER Rondelle	1	314401-5383A	
102	5144-015-385A-X	NUT Ecrou	1	314401-5385A	
103	5144-015-388A-X	SPRING Ressort	1	314401-5388A	
104	5144-015-321B-X	SPRING Ressort	2	314401-5321B	
105	5214-B04-20AX-X	SCREW/M4×20 Vis	2	214B0420A	
106	5144-065-317A-X	SPRING Ressort	1	314406-5317A	
107	5144-055-513A-X	LINK Timonerie	1	314405-5513A	
108	5171-965-5150-0	GROMMET Bague de passage	1	317196-5515-00	
109	5144-196-100A-X	CRABURETOR ASSY Carburateur	1	314419-6100A	See Fig. C-1 Voir Fig. C-1
110	5144-066-131A-X	GASKET Joint	1	314406-6131A	
111	5144-016-181A-X	INSULATOR Isolateur	1	314401-6181A	
112	5144-016-184A-X	GASKET Joint	2	314401-6184A	
113	5214-B06-16XX-X	SCREW/M6×16 Vis	2	214B0616	
114	5214-B06-25XX-X	SCREW/M6×25 Vis	2	214B0625	
115	5312-B06-00XX-X	NUT/M6 Ecrou	2	312B0600	
116	5411-B06-00XX-X	WASHER, PL/M6 Rondelle	2	411B0600	
117	5171-G06-20XX-X	STUD Goujon	1	171G0620	

Ref. No. Réf. No.	Part No. Pièces No.	Description Désignation	Q'ty Quant.	Remarks Remarques
118	5171-G06-38XX-X	STUD Goujon	1	171G0638
119	5751-Q06-00XX-X	GASKET Joint	4	751Q0600
120	5144-196-610A-X	FUEL TANK ASSY Reservoir	1	314419-6610A
121	5182-907-4470-0	●GASKET Joint	1	318290-7447-00
122	5144-126-525A-X	●BOLT Vis	1	314412-6525A
123	5144-066-661C-X	●STRAINER, FUEL Filtre	1	314406-6661C
124	5144-016-640B-X	●CAP, TANK Bouchon de reservoir	1	314401-6640B
125	5144-016-643E-X	●●GASKET, TANK CAP Joint	1	314401-6643E
126	5144-016-644A-X	●●SPRING Ressort	1	314401-6644A
127	5144-016-732A-X	●●SCREW Vis	2	314401-6732A
128	5112-B08-16XX-X	BOLT/M8×16 Vis	1	112B0816
129	5144-016-681A-X	WASHER Rondelle	1	314401-6681A
130	5144-066-760A-X	CHAMBER ASSY Chambre	1	314406-6760A
131	5214-B03-16AX-X	SCREW/M3×16 Vis	4	214B0316A
132	5410-B03-00XX-X	WASHER, PL/M3 Rondelle	4	410B0300
133	5144-017-411A-X	GAUGE, OIL Jauge	2	314401-7411A
134	5670-B20-15XX-X	O-RING Joint torique	2	670B2015
135	5144-017-441B-X	PLUG, DRAIN Bouchon de vidange	2	314401-7441B
136	5145-987-431A-X	PLUG, OIL Bouchon de remplissage	1	314598-7431A
137	5144-018-111A-X	FLYWHEEL Rotor	1	314401-8111A
138	5144-018-103C-X	IGNITION COIL ASSY Bobine d'allum.	1	314401-8103C
139	5144-018-123C-X	●COIL, IGNITION Condensateur	1	314401-8123C
140	5144-018-436A-X	●CONDENSER Condensateur	1	314401-8436A
141	5144-018-440A-X	●BREAKER, CONTACT Rupteur	1	314401-8440A
142	5144-018-142A-X	BRUSH Balai	1	314401-8142A
143	5144-018-129A-X	CLAMP Collier	1	314401-8129A
144	5144-018-161A-X	CLAMP Collier	1	314401-8161A
145	5144-018-172B-X	COVER Couvre	1	314401-8172B
146	5144-018-414B-X	RING Bague	1	314401-8414B
147	5131-B05-20XX-X	BOLT/M5×20 Vis	2	131B0520
148	5241-B04-08XX-X	SCREW/M4×8 Vis	4	241B0408
149	5242-B04-10AX-X	SCREW/M4×10 Vis	1	242B0410A
150	5144-018-164A-X	GROMMET Passe fil	1	314401-8164A
151	5314-G14-00XX-X	NUT/M14 Ecrou	1	314G1400
152	5136-502-3710-0	KEY Clavette	1	313650-2371-00
153	5144-013-482A-X	WASHER Rondelle	1	314401-3482A
154	5144-018-410A-X	PLUG, SPARK/NGK BM6A Bougie d'allumage	1	314401-8410A
155	5172-708-418A-X	CAP, PLUG Capuchon	1	317270-8418A
156	5172-708-419A-X	SPRING Ressort	1	317270-8419A

Ref. No. Réf. No.	Part No. Pièces No.	Description Désignation	Q'ty Quant.	Remarks Remarques
157	5132-522-3830-0	WASHER, PULLEY Rondelle	1	313252-2383-00
158	5180-B08-25XX-X	BOLT/M8×25 Vis	1	18080825
159	5511-A05-20XX-X	KEY Clavette	1	511A0520
160	5154-870-811A-X	LABEL, MARK Etiquette	1	315487-0811A *
161	5144-190-813A-X	LABEL, HORSE POWER Etiquette	1	314419-0813A *
162	5144-190-826A-X	LABEL Etiquette	1	314419-0826A *
163	5154-830-851A-X	LABEL Etiquette	1	315483-0851A *
ACCESSORY Accessoire				
	5144-190-900A-X	TOOL ASSY Outils	1	314419-0900A *
	5144-060-931A-X	•WRENCH, SOCKET/19 Cle tube	1	314406-0931A *
	5151-200-9450-0	•BAR Lever	1	315120-0945-00 *
	5112-200-9720-0	•GAUGE, THICKNESS Cales d'epaisseur	1	311220-0972-00 *

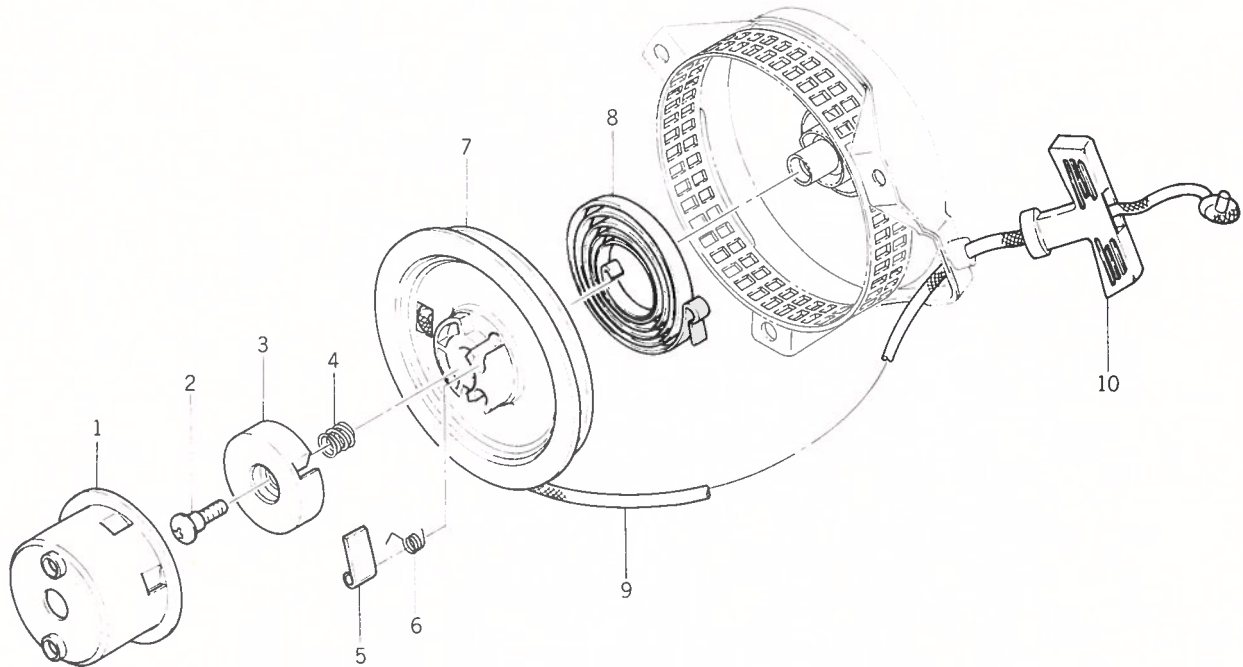
Fig. A-1 AIR CLEANER  
Filtre a air



Ref. No. Réf. No.	Part No. Pièces No.	Description Désignation	Q'ty Quant.	Remarks Remarques
	5144-191-310A-X	AIR CLEANER ASSY Filtre a air	1	314419-1310A
A-1- 1	5174-741-325A-X	•NUT Ecrou	1	317474-1325A
A-1- 2	5172-951-3210-0	•WASHER Rondelle	1	317295-1321-00
A-1- 3	5174-741-323A-X	•GASKET Joint	1	317474-1323A
A-1- 4	5144-191-316A-X	•COVER, AIR CLEANER Cloche	1	314419-1316A
A-1- 5	5144-191-312A-X	•ELEMENT Cartouche	1	314419-1312A
A-1- 6	5144-191-313A-X	•ELEMENT Cartouche	1	314419-1313A
A-1- 7	5144-191-311A-X	•PLATE, AIR CLEANER Grille	1	314419-1311A
A-1- 8	5144-191-329A-X	••DUCT, AIR Conduit	4	314419-1329A

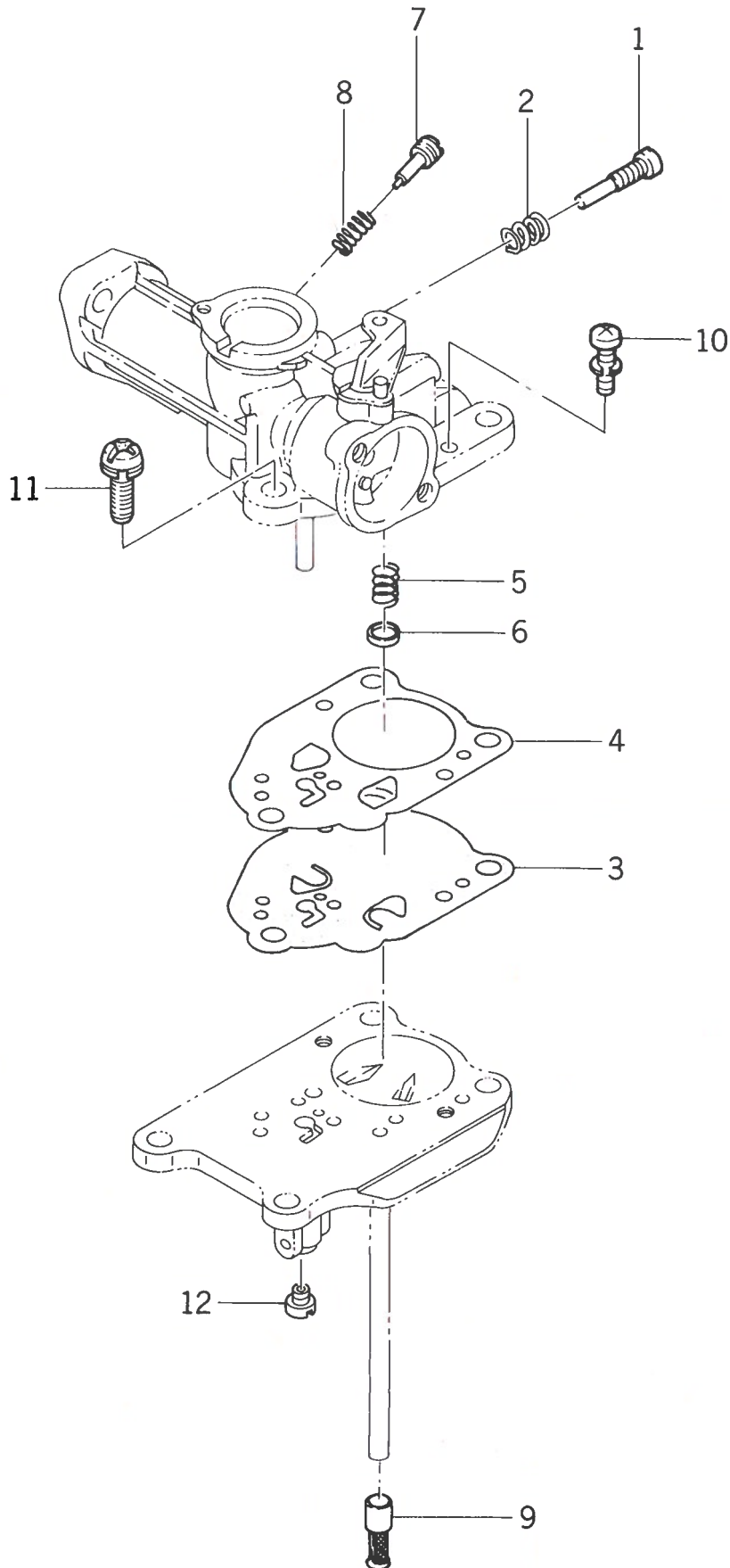


Fig. R-1 RECOIL STARTER  
Lanceur



Ref. No. Réf. No.	Part No. Pièces No.	Description Désignation	Q'ty Quant.	Remarks Remarques
	5144-193-430A-X	RECOIL STARTER ASSY Lanceur complet	1	314419-3430A
R-1- 1	5144-013-432A-X	•PULLEY Poulie d'entraînement	1	314401-3432A
R-1- 2	5144-013-447A-X	•SCREW Vis	1	314401-3447A
R-1- 3	5144-013-449A-X	•RETAINER Plaquette frein	1	314401-3449A
R-1- 4	5144-013-446A-X	•SPRING Ressort	1	314401-3446A
R-1- 5	5144-013-445A-X	•PAWL, RECOIL STARTER Cliquet	1	314401-3445A
R-1- 6	5144-013-444A-X	•SPRING, RETURN Ressort de rappel	1	314401-3444A
R-1- 7	5144-013-441A-X	•REEL, RECOIL Bobine de renvidage	1	314401-3441A
R-1- 8	5144-013-452A-X	•SPRING, RECOIL Ressort	1	314401-3452A
R-1- 9	5144-013-453A-X	•ROPE/4×1120 Cordon	1	314401-3453A
R-1-10	5144-013-460A-X	•HANDLE, RECOIL STARTER Poignée	1	314401-3460A

Fig. C-1 CARBURETOR  
Carburateur



Ref. No. Réf. No.	Part No. Pièces No.	Description Désignation	Q'ty Quant.	Remarks Remarques
	5144-196-100A-X	CARBURETOR ASSY Carburateur	1	314419-6100A
C-1- 1	5144-016-114A-X	•SCREW, SLOW STOP Vis	1	314401-6114A
C-1- 2	5144-016-116A-X	•SPRING Ressort	1	314401-6116A
C-1- 3	5144-016-160A-X	•DIAPHRAGM Diaphragme	1	314401-6160A
C-1- 4	5144-016-171A-X	•GASKET Joint	1	314401-6171A
C-1- 5	5144-016-164A-X	•SPRING Ressort	1	314401-6164A
C-1- 6	5144-016-167A-X	•CAP, SPRING Cuvette de ressort	1	314401-6167A
C-1- 7	5144-016-115A-X	•SCREW, ADJUST Vis de butee	1	314401-6115A
C-1- 8	5115-096-1170-0	•SPRING Ressort	1	311509-6117-00
C-1- 9	5128-016-168A-X	•STRAINER Filtre	1	312801-6168A
C-1-10	5232-804-14AX-X	•SCREW/M4×14 Vis	2	23280414A
C-1-11	5232-806-16XX-X	•SCREW/M6×16 Vis	1	23280616
C-1-12	5144-196-132A-X X	•JET, MAIN/#74 Gicleur princ	1	314419-6132A



ENGINE

Moteur

KT290

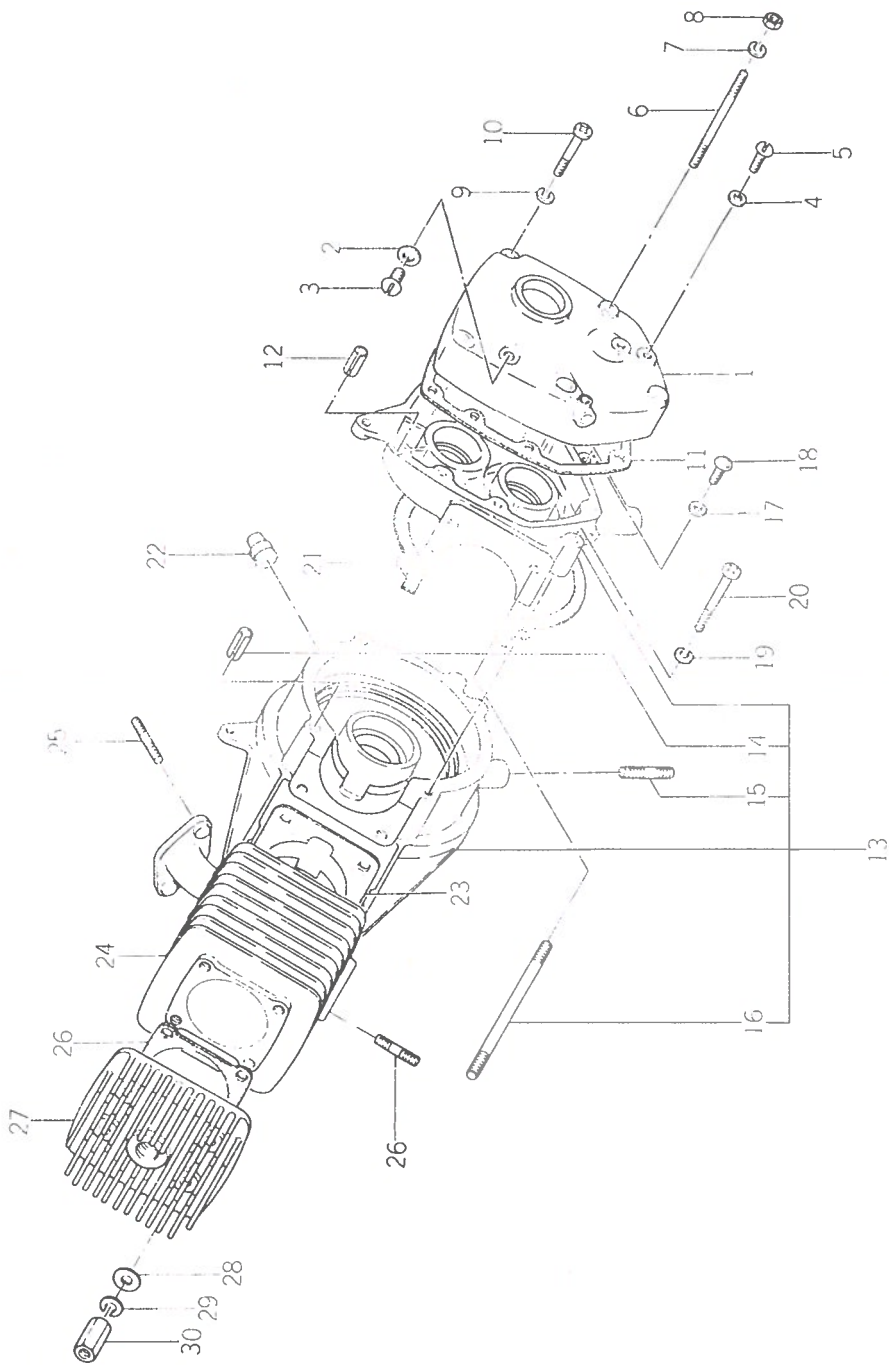
(for KS280)  
(pour KS280)





Fig. 1

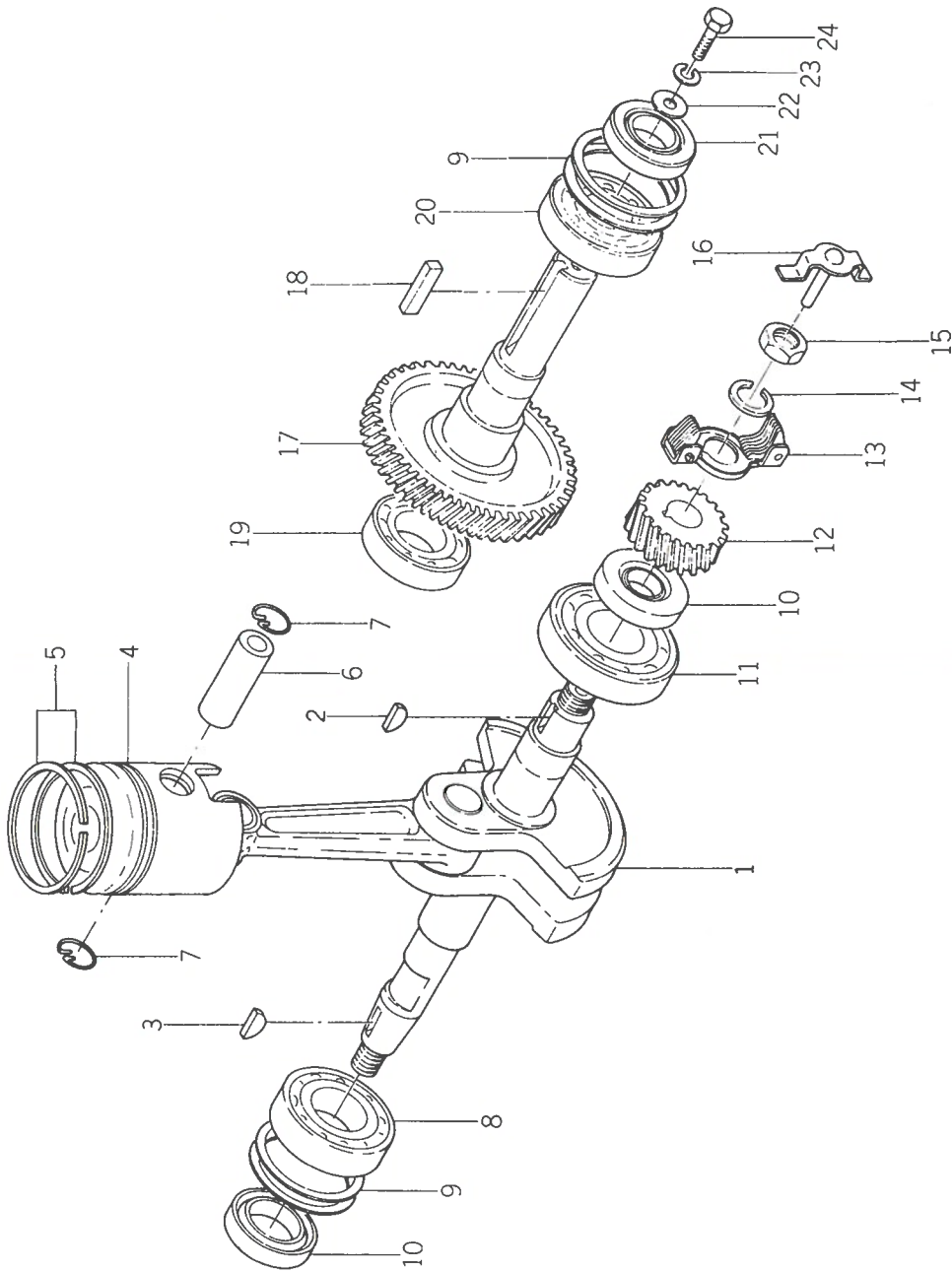
CRANK CASE AND CYLINDER  
Carter moteur





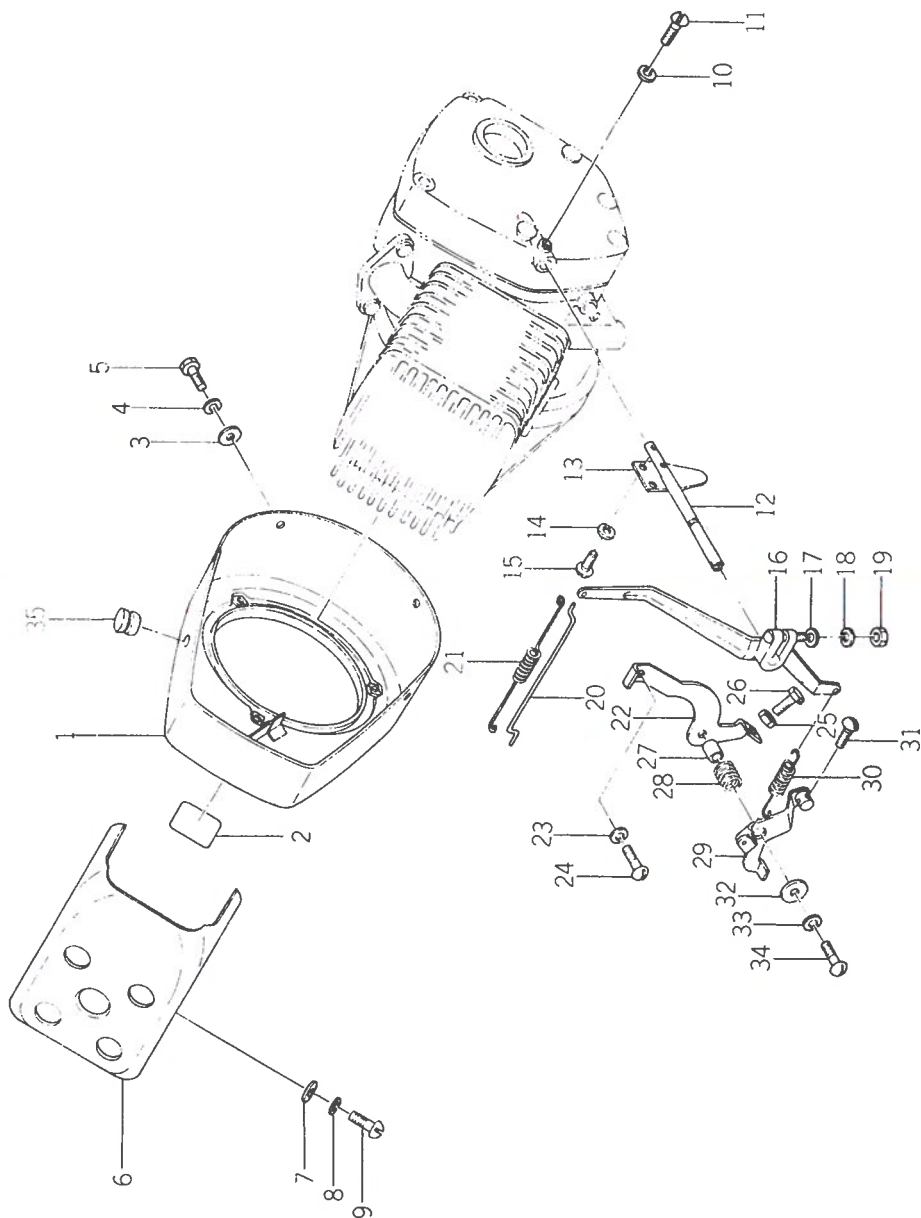
Ref No. Réf N°.	Parts No. Pièces N°.	Description Désignation	Model & Qty Modél & Quant	Remarks Remarques
1- 1	5126-513-5120-0	CASE, REDUCER Joue de carter	1	312651-3512-00
1- 2	5131-557-4320-0	GASKET, PLUG Joint	1	313155-7432-00
1- 3	5211-B08-10XX-X	SCREW/M8 × 10 Vis	1	211B 0810
1- 4	5131-226-6680-0	GASKET, PIPE JOINT Joint	2	313122-6668-00
1- 5	5211-B06-10XX-X	SCREW/M6 × 10 Vis	2	211B 0610
1- 6	5126-514-1710-0	STUD, CASE Goujon	2	312651-4171-00
1- 7	5461-F06-00AX-X	WASHER, SP/M6 Rondelle frein	2	461F 0600A
1- 8	5310-B06-00XX-X	NUT/M6 Ecroû	2	310B 0600
1- 9	5461-F06-00AX-X	WASHER, SP/M6 Rondelle frein	3	461F 0600A
1-10	5220-B06-45XX-X	SCREW/M6 × 45 Vis	3	220B 0645
1-11	5126-513-5160-0	GASKET, CASE Joint	1	312651-3516-00
1-12	5552-A10-12XX-X	PIN, DOWEL Pion	2	552A 1012
1-13	5126-514-1100-0	CASE, CRANK ASSY Carter	1	312651-4110-00 OLD PART
1-13a	5126-514-1100-6	CASE, CRANK ASSY Carter	1	312651-4110-06 NEW PART
1-14	5552-A10-12XX-X	PIN, DOWEL Pion	2	552A 1012
1-15	5172-B08-18XX-X	STUD/M8 × 18 Goujon	4	172B 0818
1-16	5126-514-1170-0	STUD Goujon	4	312651-4117-00
1-17	5131-226-6680-0	GASKET, PIPE JOINT Joint	1	313122-6668-00
1-18	5211-B06-10XX-X	SCREW/M6 × 10 Vis	1	211B 0610
1-19	5461-F06-00AX-X	WASHER, SP/M6 Rondelle frein	4	461F 0600A
1-20	5220-B06-45XX-X	SCREW/M6 × 45 Vis	4	220B 0645
1-21	5126-514-1130-0	GASKET, CRANK CASE Joint	1	312651-4113-00
1-22	5123-018-1640-0	GROMMET Bouchon	1	312301-8164-00
1-23	5123-011-2210-0	GASKET, CYL Joint	1	312301-1221-00
1-24	5126-511-2100-0	CYLINDER ASSY Cylindre	1	312651-1210-00
1-25	5171-B06-18XX-X	STUD/M6 × 18 Goujon	4	171B 0618 OLD PART
1-25a	5171-G06-18XX-X	STUD/M6 × 18 Goujon	2	171G 0618 NEW PART
1-25b	5171-G06-20XX-X	STUD/M6 × 20 Goujon	2	171G 0620 NEW PART
1-26	5126-511-1210-0	GASKET, CYL HEAD Joint	1	312651-1121-00
1-27	5126-511-1110-0	HEAD, CYL Culasse	1	312651-1111-00
1-28	5410-B06-00XX-X	WASHER/M6 Rondelle	4	410B 0600
1-29	5461-F06-00AX-X	WASHER, SP/M6 Rondelle frein	4	461F 0600A
1-30	5111-201-4840-0	NUT, LONG Ecroû colonne	4	311120-1484-00

Fig. 2 CRANK SHAFT AND CAM SHAFT  
Vilebrequin



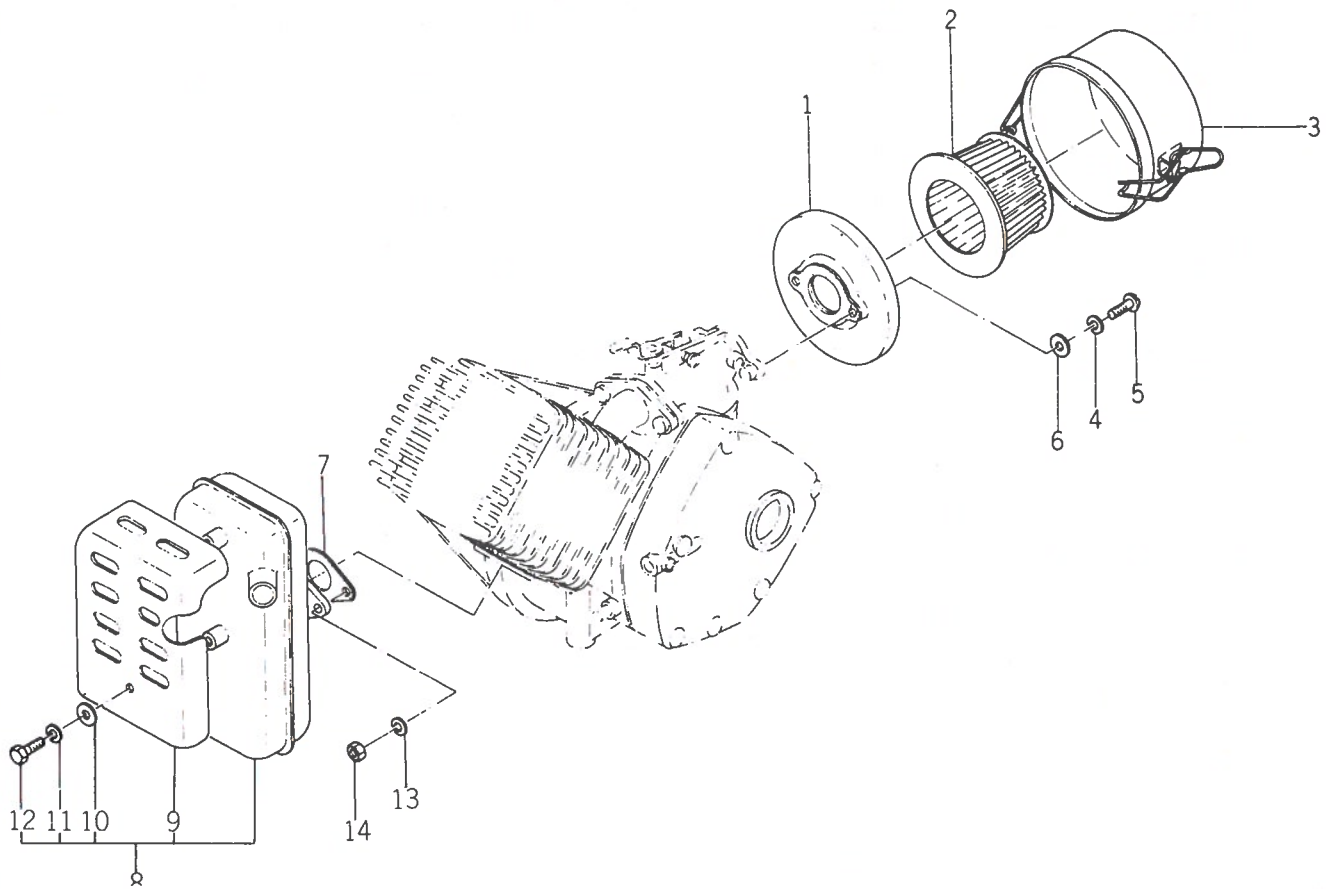
Ref No. Réf N°.	Parts No. Pièces N°.	Description Désignation	Model & Q'ty Modél & Quant	Remarks Remarques
2- 1	5126-513-2100-0	CRANKSHAFT ASSY Vilebrequin	1	312651-3210-00 OLD PART
2- 1a	5126-513-2100-2	CRANKSHAFT ASSY Vilebrequin	1	312651-3210-02 NEW PART
2- 2	5126-513-3210-0	KEY, OUTPUT SHAFT Clavette	1	312651-3321-00
2- 3	5510-A32-00XX-X	KEY Clavette	1	510A 3200
2- 4	5126-513-1110-0	PISTON Piston	1	312651-3111-00
2- 4-1	5126-AA3-131A-X	PISTON / 0.25 OS Piston	1	3126AA-3131A
2- 4-2	5126-AA3-132A-X	PISTON / 0.50 OS Piston	1	3126AA-3132A
2- 5	5121-213-0100-0	RING, PISTON SET Segmentation	1	312121-3010-00
2- 5-1	5126-AA3-020A-X	RING, PISTON SET / 0.25 OS Segmentation	1	3126AA-3020A
2- 5-2	5126-AA3-030A-X	RING, PISTON SET / 0.50 OS Segmentation	1	3126AA-3030A
2- 6	5123-013-1210-0	PIN, PISTON Axe de piston	1	312301-3121-00
2- 7	5111-203-1220-0	RING, SNAP Collet d'axe	2	311120-3122-00
2- 8	5123-014-2110-0	BEARING, RB Roulement	1	312301-4211-00
2- 9	5124-533-5340-0	SHIM/T=0.2 Cale	AR	312453-3534-00 OLD PART
2- 9a	5123-013-2320-0	SHIM Cale	AR	312301-3232-00 NEW PART
2- 9-1	5124-533-5350-0	SHIM/T=0.4 Cale	AR	312453-3535-00 OLD PART
2- 9-1a	5123-013-2330-0	SHIM Cale	AR	312301-3233-00 NEW PART
2- 9-2	5124-533-5360-0	SHIM/T=0.6 Cale	AR	312453-3536-00 OLD PART
2- 9-2a	5123-013-2340-0	SHIM Cale	AR	312301-3234-00 NEW PART
2-10	5123-014-2320-0	SEAL, OIL Bague d'étanchéité	2	312301-4232-00
2-11	5123-014-2120-0	BEARING, RB Roulement	1	312301-4212-00
2-12	5126-513-5230-0	GEAR, PINION Pignon	1	312651-3523-00
2-13	5126-515-1100-0	GOVERNOR ASSY Regulateur	1	312651-5110-00
2-14	5461-F10-00AX-X	WASHER, SP/M10 Rondelle frein	1	461F 1000A
2-15	5315-G10-00XX-X	NUT/M10 Ecrou	1	315G 1000
2-16	5126-515-1210-0	SLEEVE, GOVERNOR Manchon	1	312651-5121-00
2-17	5126-513-5200-0	SHAFT, OUTPUT Pignon	1	312651-3520-00
2-18	5511-A05-20XX-X	KEY Clavette	1	511A 0520
2-19	5601-A62-02XX-X	BEARING, RB/6202 Roulement	1	601A 6202
2-20	5601-A62-03XX-X	BEARING, RB/6203 Roulement	1	601A 6203
2-21	5123-034-2420-0	SEAL, OIL Bague d'étanchéité	1	312303-4242-00
2-22	5122-005-3830-0	WASHER Rondelle	1	312200-5383-00
2-23	5461-F06-00AX-X	WASHER, SP/M6 Rondelle frein	1	461F 0600A
2-24	5110-B06-16XX-X	BOLT/M6 x 16 Vis	1	110B 0616

Fig. 3 SPIRAL CASE AND GOVERNOR  
Volute & regulateur



Ref No. Réf N°.	Parts No. Pièces N°.	Description Désignation	Model & Q'ty Modél & Quant	Remarks Remarques
3- 1	5126-511-6110-0	CASE, SPIRAL Volute	1	312651-1611-00 OLD PART
3- 1a	5126-901-6110-2	CASE, SPIRAL Volute	1	312690-1611-02 NEW PART
3- 2	5126-900-8110-0	LABEL, ENGINE Etiquettes	1	312690-0811-00
3- 3	5410-B06-00XX-X	WASHER/M6 Rondelle	4	410B 0600
3- 4	5461-F06-00AX-X	WASHER, SP/M6 Rondelle frein	4	461F 0600A
3- 5	5110-B06-12XX-X	BOLT/M6 × 12 Vis	4	110B 0612
3- 6	5126-511-6320-0	COVER, CYL Couvre culase	1	312651-1632-00 OLD PART
3- 6a	5126-901-6320-0	COVER, CYL Couvre culase	1	312690-1632-00 NEW PART
3- 7	5410-B06-00XX-X	WASHER/M6 Rondelle	2	410B 0600
3- 8	5461-F06-00AX-X	WASHER, SP/M6 Rondelle frein	2	461F 0600A
3- 9	5211-B06-10XX-X	SCREW/M6 × 10 Vis	2	211B 0610
3-10	5461-F04-00XX-X	WASHER, SP/M4 Rondelle frein	1	461F 0400
3-11	5122-005-1240-2	STOPPER, GOVERNOR Vis	1	312200-5124-02
3-12	5126-515-1230-0	SHAFT Axe	1	312651-5123-00
3-13	5126-515-1220-0	TIP, GOVERNOR Doigt	1	312651-5122-00
3-14	5461-F04-00XX-X	WASHER, SP/M4 Rondelle frein	2	461F 0400
3-15	5211-B04-06AX-X	SCREW/M4 × 6 Vis	2	211B 0406A
3-16	5126-515-2110-0	ARM, GOVERNOR Bras	1	312651-5211-00
3-17	5410-B06-00XX-X	WASHER/M6 Rondelle	1	410B 0600
3-18	5461-F06-00AX-X	WASHER, SP/M6 Rondelle frein	1	461F 0600A
3-19	5310-B06-00XX-X	NUT/M6 Ecrou	1	310B 0600
3-20	5126-515-2310-0	LINK, GOVERNOR Biellette	1	312651-5231-00
3-21	5126-515-2320-0	SPRING, LINK Ressort	1	312651-5232-00
3-22	5126-515-3350-0	BRACKET, CABLE Plaque	1	312651-5335-00
3-23	5461-F06-00AX-X	WASHER, SP/M6 Rondelle frein	1	461F 0600A
3-24	5211-B06-10XX-X	SCREW/M6 × 10 Vis	1	211B 0610
3-25	5312-B06-00XX-X	NUT/M6 Ecrou	1	312B 0600
3-26	5110-B06-16XX-X	BOLT/M6 × 16 Vis	1	110B 0616
3-27	5122-005-3190-0	COLLAR, CONTROL LEVER Coussinet	1	312200-5319-00
3-28	5126-515-3170-0	SPRING, RETURN Ressort	1	312651-5317-00
3-29	5126-515-3100-0	LEVER ASSY Lever	1	312651-5310-00
3-30	5126-515-3140-0	SPRING, GOVERNOR Ressort	1	312651-5314-00
3-31	5211-B05-10AX-X	SCREW/M5 × 10 Vis	1	211B 0510A
3-32	5122-005-3830-0	WASHER, COLLAR Rondelle	1	312200-5383-00
3-33	5461-F06-00AX-X	WASHER, SP/M6 Rondelle frein	1	461F 0600A
3-34	5211-B06-25XX-X	SCREW/M6 × 25 Vis	1	211B 0625
3-35	5126-931-6710-0	PLUG Bouchon	1	312693-1671-00 OLD PART

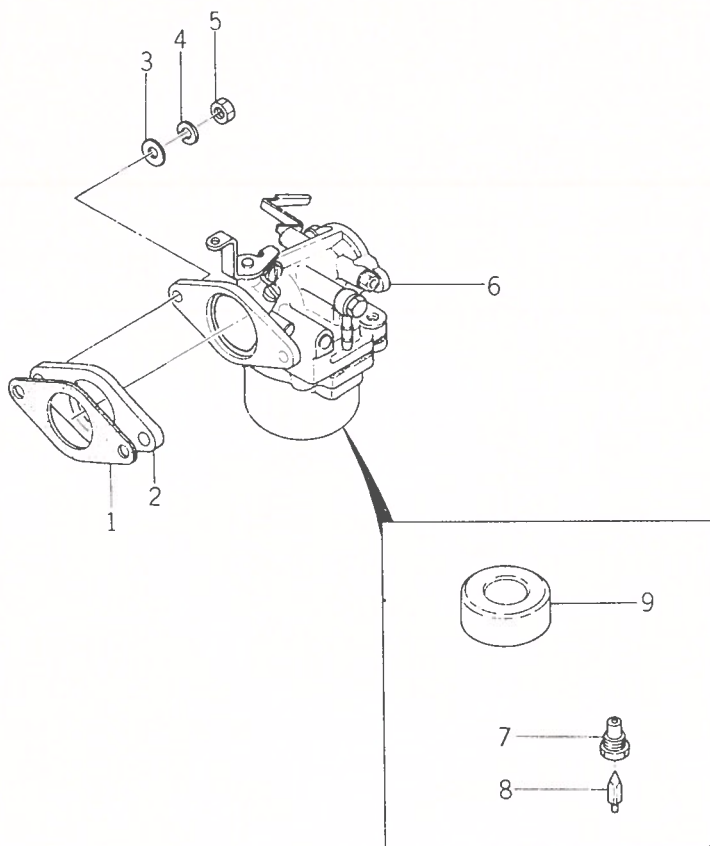
Fig. 4 AIR CLEANER AND MUFFLER  
Filtre a air et silencieux



**No. 4**

Ref No. Réf N°.	Parts No. Pièces N°.	Description Désignation	Model & Q'ty Modél & Quant	Remarks Remarques
4- 0-1	5126-901-3100-0	CLEANER, AIR ASSY Filtre a air	1	312690-1310-00
4- 1	5126-901-3130-0	·PLATE Grille	1	312690-1313-00
4- 2	5126-901-3120-0	·ELEMENT Cartouche	1	312690-1312-00
4- 3	5126-901-3110-0	·COVER Cloche	1	312690-1311-00
4- 4	5461-F05-00AX-X	WASHER, SP/M5 Rondelle frein	2	461F 0500A
4- 5	5211-B05-25AX-X	SCREW/M5 × 25 Vis	2	211B 0525A
4- 6	5410-B05-00XX-X	WASHER/M5 Rondelle	2	410B 0500
4- 7	5124-011-4430-0	GASKET, MUFFLER Joint	1	312401-1443-00
4- 8	5126-511-4100-0	MUFFLER ASSY Silencieux	1	312651-1410-00
4- 9	5126-511-4310-0	·COVER, MUFFLER Protecteur	1	312651-1431-00
4-10	5410-B06-00XX-X	·WASHER/M6 Rondelle	2	410B 0600
4-11	5461-F06-00AX-X	·WASHER, SP/M6 Rondelle frein	2	461F 0600A
4-12	5110-B06-08XX-X	·BOLT/M6 × 8 Vis	2	110B 0608
4-13	5461-F06-00AX-X	WASHER, SP/M6 Rondelle frein	2	461F 0600A
4-14	5310-B06-00XX-X	NUT/M6 Ecrou	2	310B 0600

Fig. 5 CARBURETOR  
Carburateur

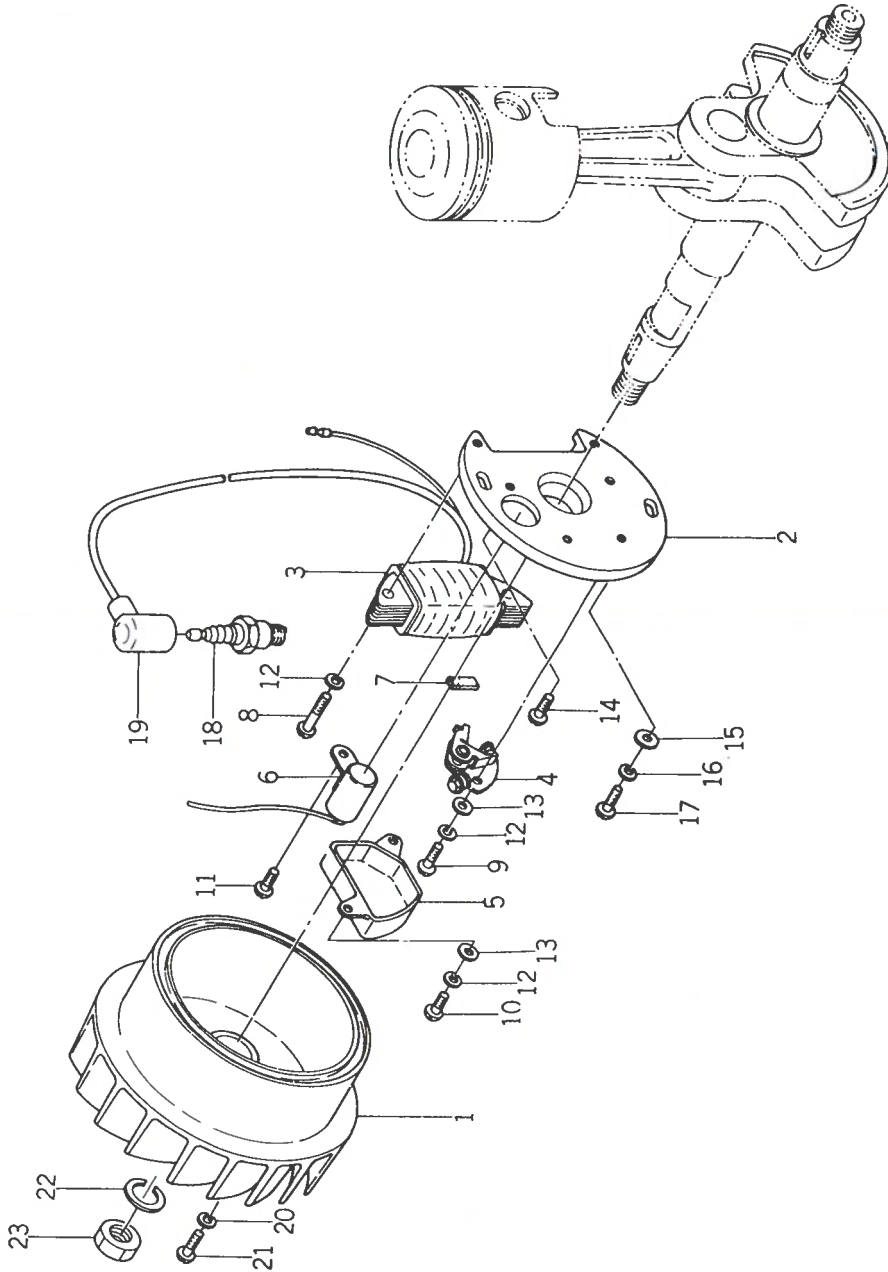


**No. 5**

Ref No. Réf N°.	Parts No. Pièces N°.	Description Désignation	Model & Q'ty Modél & Quant	Remarks Remarques
5- 1	5123-026-1860-0	GASKET, CARBURETOR Joint	1	312302-6186-00
5- 2	5126-516-1810-0	INSULATOR Isolant	1	312651-6181-00
5- 3	5410-B06-00XX-X	WASHER/M6 Rondelle	2	410B 0600
5- 4	5461-F06-00AX-X	WASHER, SP/M6 Rondelle frein	2	461F 0600A
5- 5	5312-B06-00XX-X	NUT/M6 Ecrrou	2	312B 0600
5- 6	5126-516-1000-0	CARBURETOR ASSY Carburateur	1	312651-6100-00
5- 7	5113-906-1210-0	·SEAT, VALVE Siege	1	311390-6121-00
5- 8	5124-016-1220-0	·VALVE, NEEDLE Pointeau	1	312401-6122-00
5- 9	5124-016-1260-0	·FLOAT Flotteur	1	312401-6126-00

Fig. 6

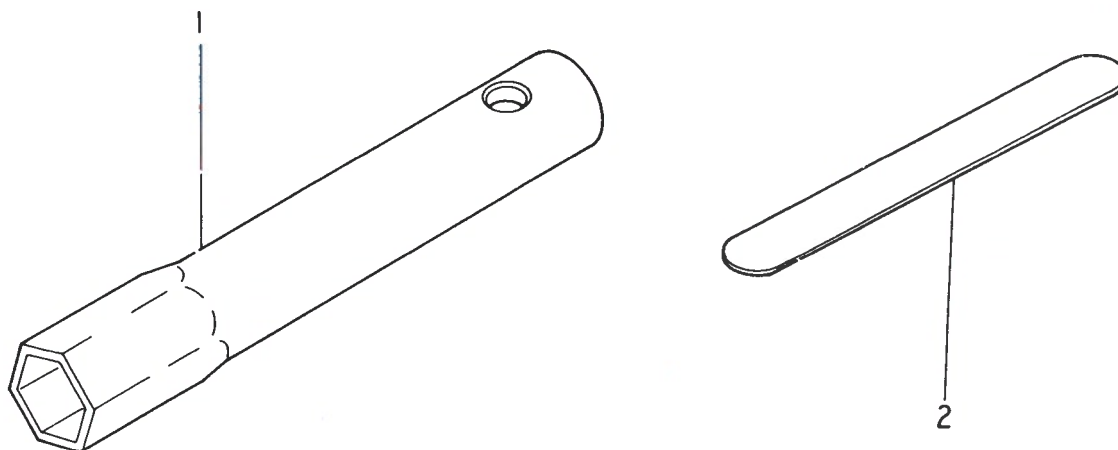
FLYWHEEL AND MAGNET  
Volant magnetique





Ref No. Réf N°.	Parts No. Pièces N°.	Description Désignation	Model & Qty Modél & Quant	Remarks Remarques
6- 0-1	5126-518-1100-0	MAGNETO ASSY Volant magnetique	1	312651-8110-00
6- 1	5126-518-1110-0	·FLY WHEEL Rotor	1	312651-8111-00
6- 2	5126-518-1200-0	·BASE ASSY Plateau	1	312651-8120-00
6- 3	5126-518-1230-0	··COIL, IGNITION Bobine d'allum.	1	312651-8123-00
6- 4	5126-518-4400-0	··BREAKER Rupteur	1	312651-8440-00
6- 5	5126-518-4390-0	··COVER Couvercle	1	312651-8439-00
6- 6	5126-518-4360-0	··CONDENSER Condensateur	1	312651-8436-00
6- 7	5126-518-4510-0	··FELT, CAM Feutre huileur	1	312651-8451-00
6- 8	5126-518-1280-0	··SCREW Vis	2	312651-8128-00
6- 9	5126-518-4440-0	··SCREW Vis	1	312651-8444-00
6-10	5126-518-4480-0	··SCREW Vis	2	312651-8448-00
6-11	5131-228-4480-0	··SCREW Vis	1	313122-8448-00
6-12	5131-228-1390-0	··WASHER, SP Rondelle frein	5	313122-8139-00
6-13	5126-518-4420-0	··WASHER Rondelle	3	312651-8442-00
6-14	5126-518-1410-0	··SCREW Vis	1	312651-8141-00
6-15	5410-B05-00XX-X	WASHER/M5 Rondelle	2	410B 0500
6-16	5461-F05-00AX-X	WASHER, SP/M5 Rondelle frein	2	461F 0500A
6-17	5211-B05-14AX-X	SCREW/M5 x 14 Vis	2	211B 0514A
6-18	5122-008-4100-0	PLUG, SPARK Bougie	1	312200-8410-00
6-19	5111-208-4120-0	CAP, PLUG Capuchon	1	311120-8412-00 OLD PART
6-19a	5155-098-4180-2	CAP, PLUG Capuchon	1	311509-8418-02 NEW PART
6-19b	5115-098-4190-2	SPRING Ressort	1	311509-8419-02 NEW PART
6-20	5461-F06-00AX-X	WASHER, SP/M6 Rondelle frein	1	461F 0600A
6-21	5211-B06-10XX-X	SCREW/M6 x 10 Vis	1	211B 0610
6-22	5461-F10-00AX-X	WASHER, SP/M10 Rondelle frein	1	461F 1000A
6-23	5315-G10-00XX-X	NUT/M10 Ecroû	1	315G 1000

Fig. 7 TOOLS  
Outils



**No. 7**

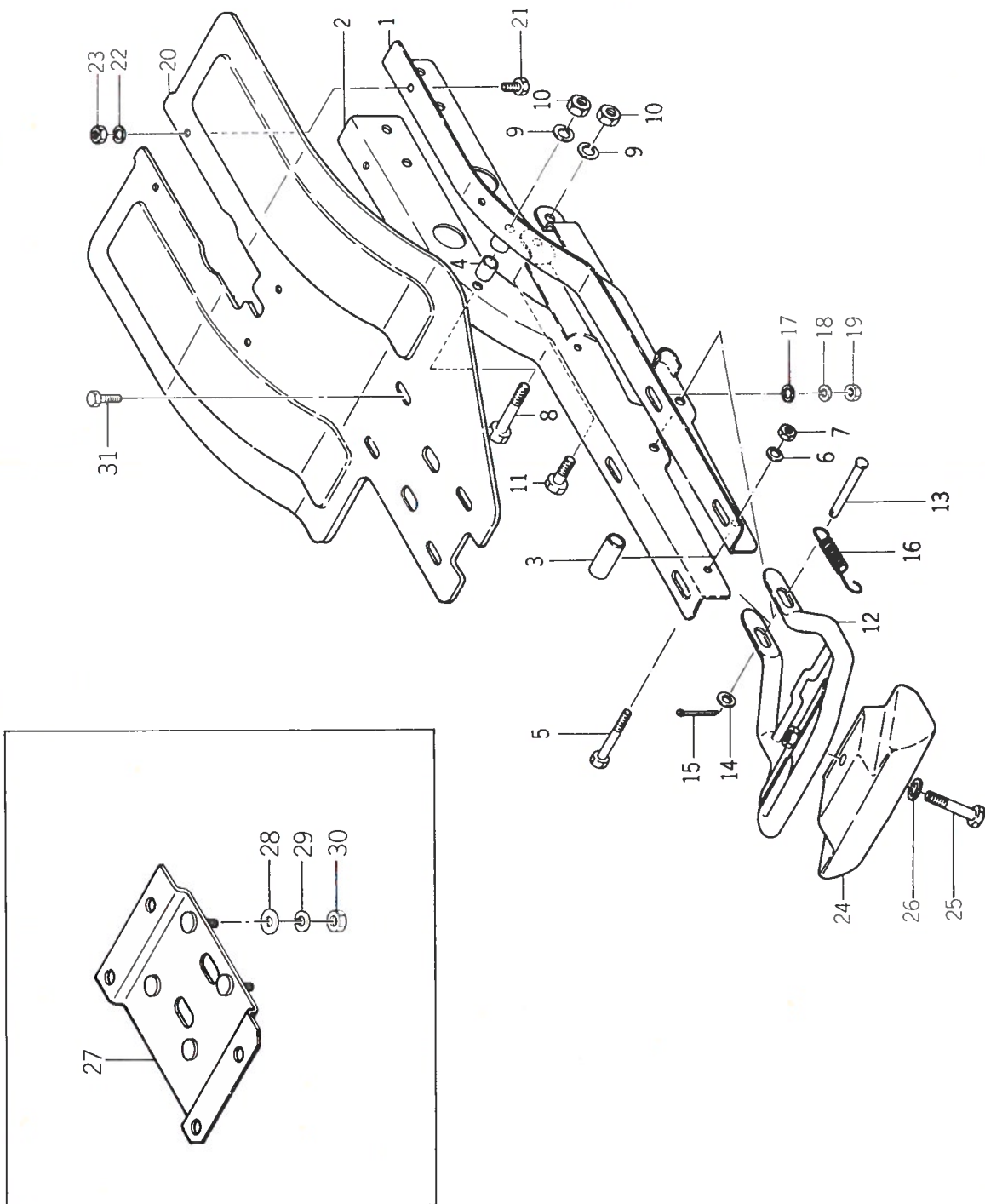
Ref No. Réf N°.	Parts No. Pièces N°.	Description Désignation	Model & Qty Modél & Quant	Remarks Remarques
7- 0-1	5126-900-9000-0	TOOL ASSY Outils	1	312690-0900-00
7- 1	5122-000-9410-0	·WRENCH, SOCKET Cle a pipe	1	312200-0941-00 OLD PART
7- 1a	5131-220-9420-1	·WRENCH Cle a pipe	1	313122-0942-01 NEW PART
7- 2	5112-200-9720-0	·GAUGE, THICKNESS Jauge	1	311220-0972-00

**C H A S S I S**



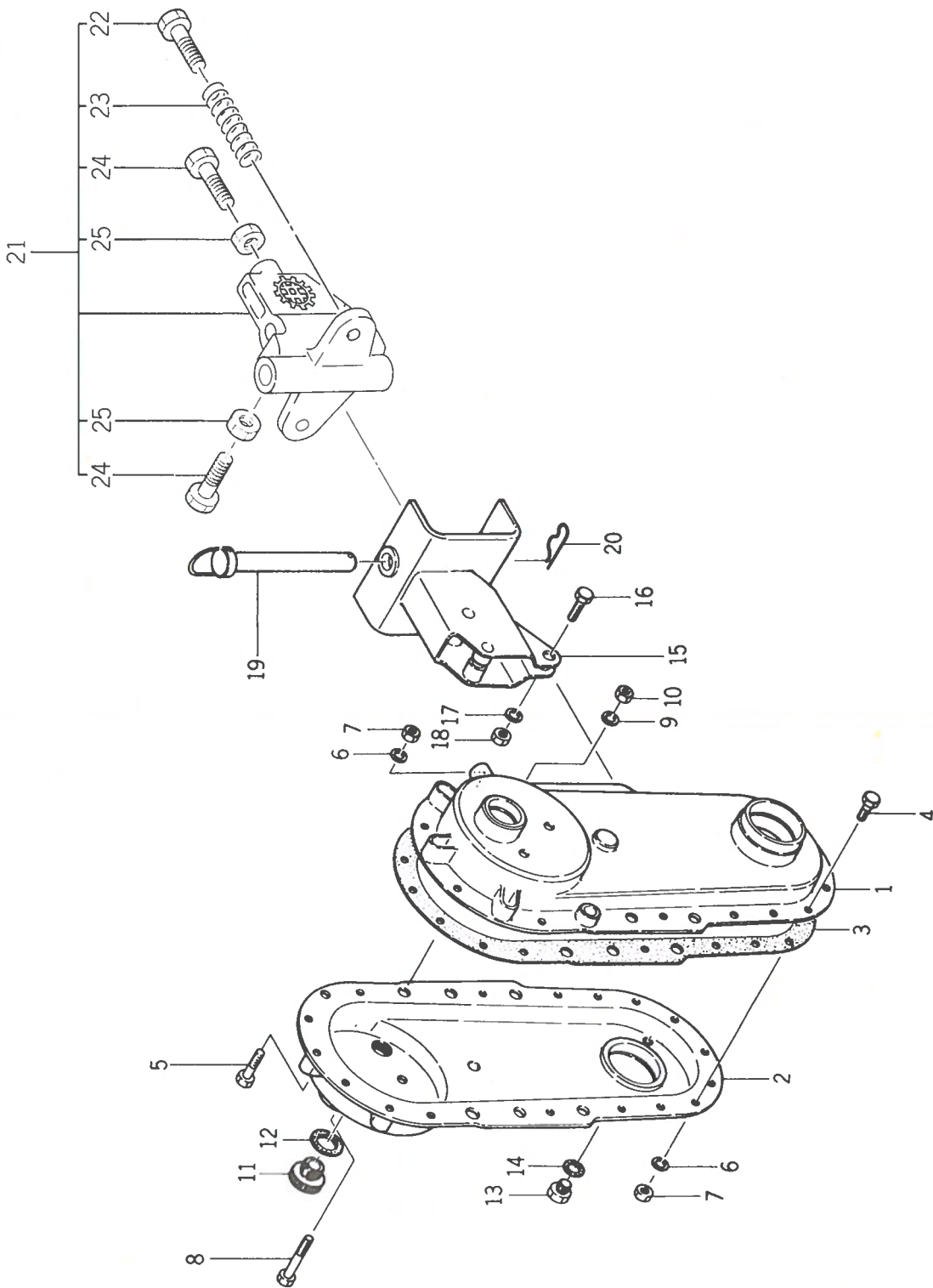


Fig. 8 FRAME  
Longeron



Ref No. Réf No.	Parts No. Pièces No.	Description Désignation	Model & Q'ty Modél & Quant	Remarks Remarques
8- 1	1353-101-1000-0	FRAME LH Longeron G.	1	
8- 2	1353-101-2000-0	FRAME RH Longeron D.	1	
8- 3	1350-101-0010-0	PIPE/39 Tubulure	2	
8- 4	1350-101-0020-0	PIPE/17 Tubulure	2	
8- 5	V20126-080560	BOLT/M8×56 Vis	2	
8- 6	V40116-000800	WASHER, SP/M8 Rondelle frein	2	
8- 7	V30026-000800	NUT/M8 Erou	2	
8- 8	V20126-100600	BOLT/M10×60 Vis	3	
8- 9	V40116-001000	WASHER, SP/M10 Rondelle frein	4	
8-10	V30026-001000	NUT/M10 Erou	4	
8-11	V20126-100220	BOLT/M10×22 Vis	1	
8-12	1353-106-1000-0	STAND Bequille	1	
8-13	1353-106-0010-0	PIN, STAND Axe de bequille	1	
8-14	V41316-000800	WASHER, PL/M8 Rondelle	1	
8-15	V50015-300200	PIN, SPLIT/3×20 Goupille fendue	1	
8-16	1350-106-0020-0	SPRING, TENSION Ressort	1	
8-17	V41316-000800	WASHER, PL/M8 Rondelle	4	
8-18	V40116-000800	WASHER, SP/M8 Rondelle frein	4	
8-19	V30026-000800	NUT/M8 Erou	4	
8-20	1353-616-0010-0	FENDER Garde-boue	1	
8-21	V20026-060120	BOLT/M6×12 Vis	4	
8-22	V40116-000600	WASHER, SP Rondelle	4	
8-23	V30026-000600	NUT/M6 Erou	4	
8-24	1329-931-0010-0	WEIGHT, BALANCE Contrepoids	1	★
8-25	V20126-100650	BOLT/M10×65 Vis	1	★
8-26	V40116-001000	WASHER, SP/M10 Rondelle frein	1	★
8-27	1353-151-2100-0	BASE, ENGINE Semelle	1	} for 4-cycle type
8-28	1373-121-0010-0	WASHER/9×22×2 Rondelle	4	
8-29	V401-160-0080-0	WASHER, SP/M8 Rondelle frein	4	
8-30	V300-260-0080-0	NUT/M8 Erou	4	
8-31	V201-260-8040-0	BOLT/M8×40 Vis	4	

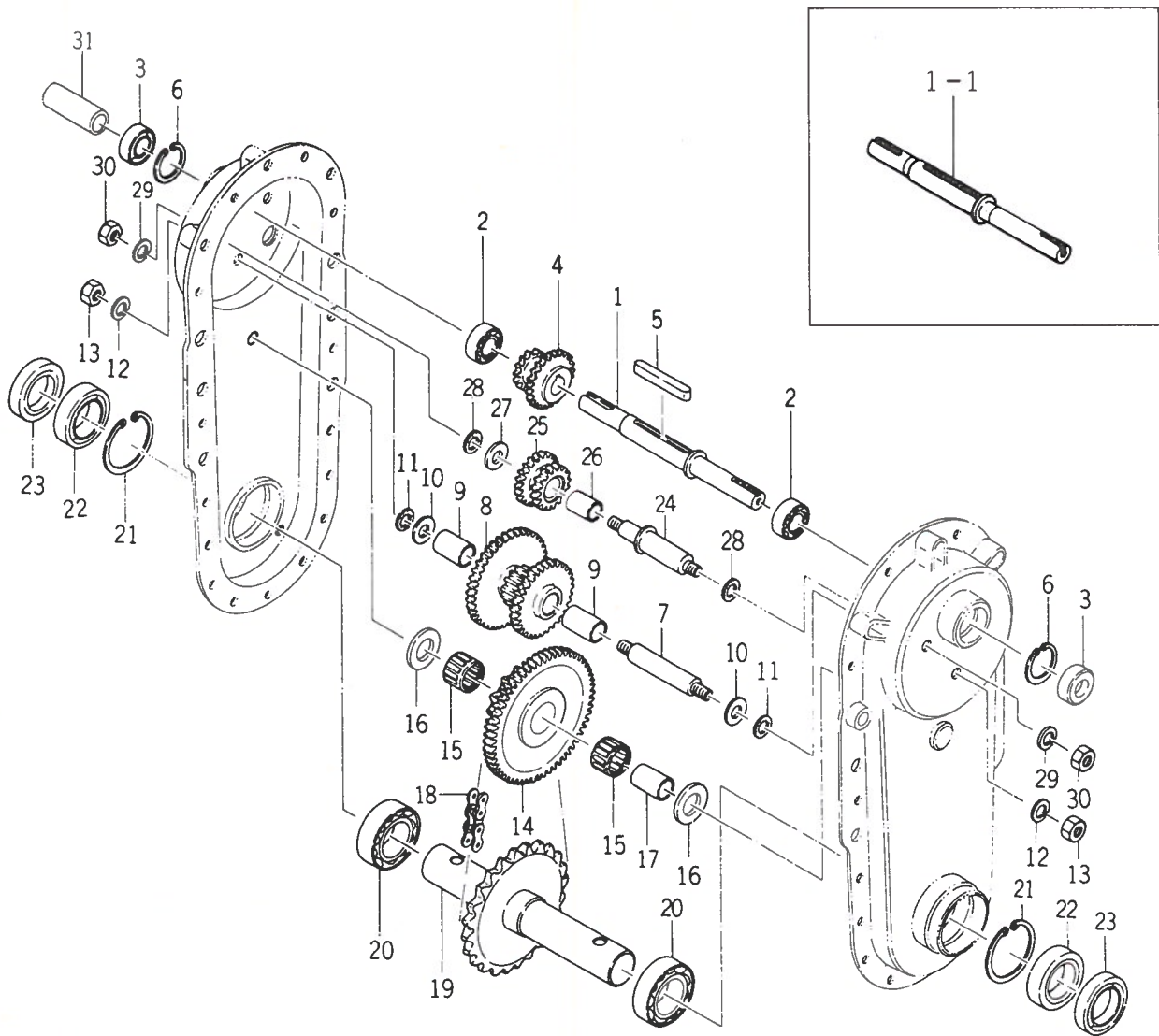
Fig. 9 TRANSMISSION GEAR CASE  
Boitier de reducteur





Ref No. Réf N°.	Parts No. Pièces N°.	Description Désignation	Model & Q'ty Modél & Quant	Remarks Remarques
9- 1	1350-216-1001-0	CASE, GEAR LH Coquille G.	1	
9- 2	1350-216-2001-0	CASE, GEAR RH Coquille D.	1	
9- 3	1350-216-0010-0	PACKING, GEAR CASE Joint	1	
9- 4	V20026-060120	BOLT/M6×12 Vis	13	
9- 5	V20026-060200	BOLT/M6×12 Vis	1	
9- 6	V40116-000600	WASHER, SP/M6 Rondelle frein	14	
9- 7	V30026-000600	NUT/M6 Ecrou	14	
9- 8	V20126-100250	BOLT/M10×25 Vis	1	
9- 9	V40116-001000	WASHER, SP/M10 Rondelle frein	1	
9-10	V30026-001000	NUT/M10 Ecrou	1	
9-11	1343-216-0020-0	PLUG Bouchon	1	
9-12	1343-216-0030-0	PACKING, PLUG Joint	1	
9-13	1344-216-0020-0	PLUG Bouchon	1	
9-14	1340-706-0040-0	PACKING, PLUG Joint	1	
9-15	1350-930-1000-0	HITCH Attelage	1	
9-16	V20126-100220	BOLT/M10×22 Vis	1	
9-17	V40116-001000	WASHER, SP/M10 Rondelle frein	1	
9-18	V30026-001000	NUT/M10 Ecrou	1	
9-19	1301-100-9010-0	PIN, KING Broche	1	
9-20	1305-931-0030-0	PIN, HAIR Attache beta	1	
9-21	8057-006-0000-0	HITCH, CULTI ASSY Attache culti ensemble	1	★
9-22	8057-006-0020-0	·BOLT Vis	2	★
9-23	8057-006-0030-0	·SPRING Ressort	2	★
9-24	W20126-120400	·BOLT/M12×40 Vis	2	★
9-25	V30226-001200	·NUT/M12 Ecrou	2	★

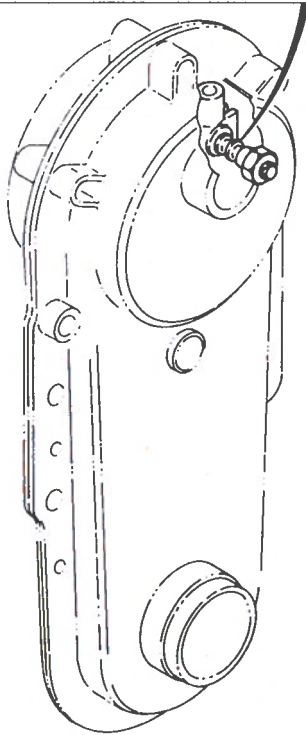
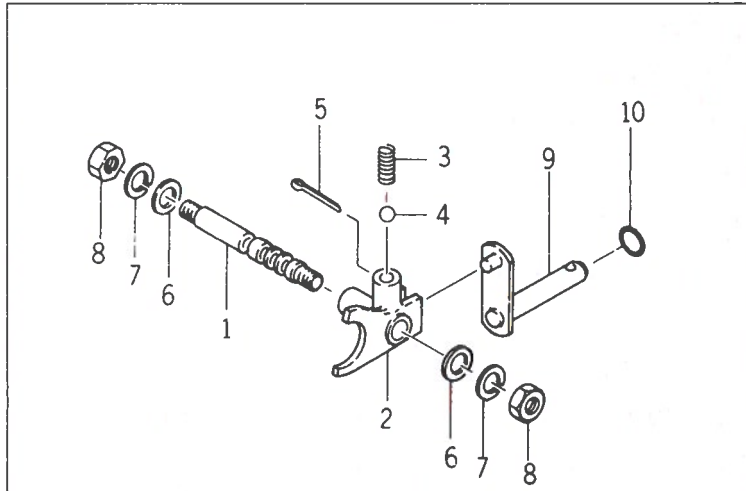
Fig. 10  
TRANSMISSION GEAR  
Reducteur



Ref No. Réf N <sup>o</sup> .	Parts No. Pièces N <sup>o</sup> .	Description Désignation	Model & Q'ty Modél & Quant	Remarks Remarques
10- 1	1350-217-0010-0	SHAFT, MAIN Arbre primaire	1	for 2-cycle type
10-1-1	1353-218- 0010-0	SHAFT, MAIN Arbre primaire	1	for 4-cycle type
10- 2	V60011-060020	BEARING, RB/6002 Roulement	2	
10- 3	V74011-532070	SEAL, OIL/SC15327 Roulement	2	
10- 4	1350-217-0020-0	GEAR, SHIFT/14-24T Baladeur	1	
10- 5	1350-217-0030-0	KEY/5×5×60 Clavette	1	
10- 6	V70514-003200	RING, SNAP/32 Collet d'axe	2	
10- 7	1350-220-0010-0	SHAFT, COUNTER Arbre intermediaire	1	
10- 8	1350-220-1000-0	GEAR, COUNTER/31-41T Pignon fou	1	
10- 9	1350-220-0020-0	BUSH, A Coussinet	2	
10-10	1350-220-0040-0	COLLAR/10×28×3 Collier	2	
10-11	1343-220-0030-0	PACKING, COUNTER SHAFT Joint	2	
10-12	V40116-001000	WASHER, SP/M10 Rondelle frein	2	
10-13	V30526-001000	NUT/M10 P1.25 Ecrou	2	
10-14	1350-221-1000-0	GEAR, REDUCTION/58-11T Pignon	1	No. 1-3900
10-14a	1350-221-1001-0	GEAR, REDUCTION Pignon	1	No. 3901-
10-15	1350-221-0010-0	BEARING, NR Roulement	2	
10-16	1343-220-0020-0	WASHER, A Rondelle, A.	2	No. 1-17920
10-16a	1350-220-0040-0	COLLAR/10×28×3 Collier	2	No. 17921-
10-17	1350-221-0030-0	BUSH/10×16×30 Coussinet	1	
10-18	1350-221-0020-0	CHAIN, ROLLER Chaine	1	No. 1-3900
10-18a	1350-221-0040-0	CHAIN, ROLLER Chaine	1	No. 3901-
10-19	1350-225-1000-0	SHAFT, WHEEL Fusse	1	No. 1-3900
10-19a	1350-225-1001-0	SHAFT, WHEEL Fusse	1	No. 3901-
10-20	V60011-060060	BEARING, RB/6006 Roulement	2	
10-21	V70514-005500	RING, SNAP/55 Collet d'axe	2	
10-22	V74413-055120	SEAL, OIL/TC305512 Bague d'etancheite	2	
10-23	V74213-055050	SEAL, OIL/VC30555 Bague d'etancheite	2	
10-24	1350-226-0010-0	SHAFT, BACK Axe de M AR	1	
10-25	1350-226-0020-0	GEAR, BACK/16-22T Pignon de M AR	1	
10-26	1350-226-0030-0	BUSH/14×17×24 Coussinet	1	
10-27	1350-220-0040-0	COLLAR/10×28×3 Collier	1	
10-28	1343-220-0030-0	PACKING Joint	2	
10-29	V40126-001000	WASHER, SP/M10 Rondelle frein	2	
10-30	V30516-001000	NUT/M10 P1.25 Ecrou	2	
10-31	1353-217-0020-0	CAP, SHAFT Chapeau d'arbre	1	Ⓓ

Fig. 11

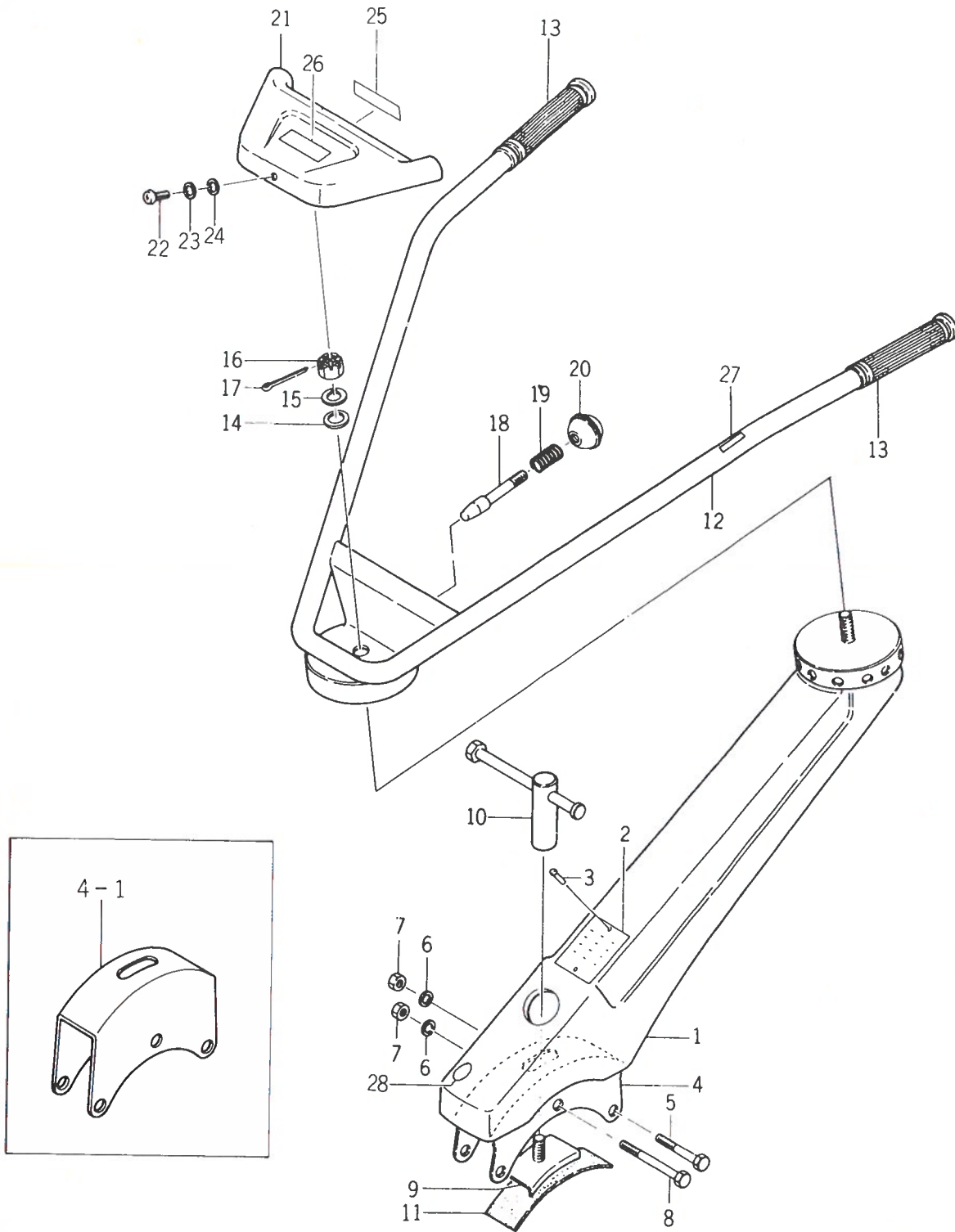
SHIFTER  
Fourchettes



Ref No. Réf N°.	Parts No. Pièces N°.	Description Désignation	Model & Q'ty Modél & Quant	Remarks Remarques
11- 1	1350-229-0010-0	STAY, SHIFTER Axe de fourchette	1	
11- 2	1350-229-0020-0	SHIFTER Fourchette	1	
11- 3	1301-229-0040-0	SPRING, SHIFTER Ressort de verrouillage	1	
11- 4	V68020-000100	BALL, STEEL Bille de verrouillage	1	
11- 5	V50015-200250	PIN, SPLIT Goupille fendue	1	
11- 6	1343-229-0040-0	PACKING, SHIFTER ROD Joint	2	
11- 7	V40116-001000	WASHER, SP/M10 Rondelle frein	2	
11- 8	V30516-001000	NUT/M10 P1.25 Ecrou	2	
11- 9	1350-229-1000-0	ARM, SHIFT Selecteur	1	
11-10	V72010-240120	O-RING/P12 Joint torique	1	

Fig. 12

HANDLE FRAME  
Mancherons

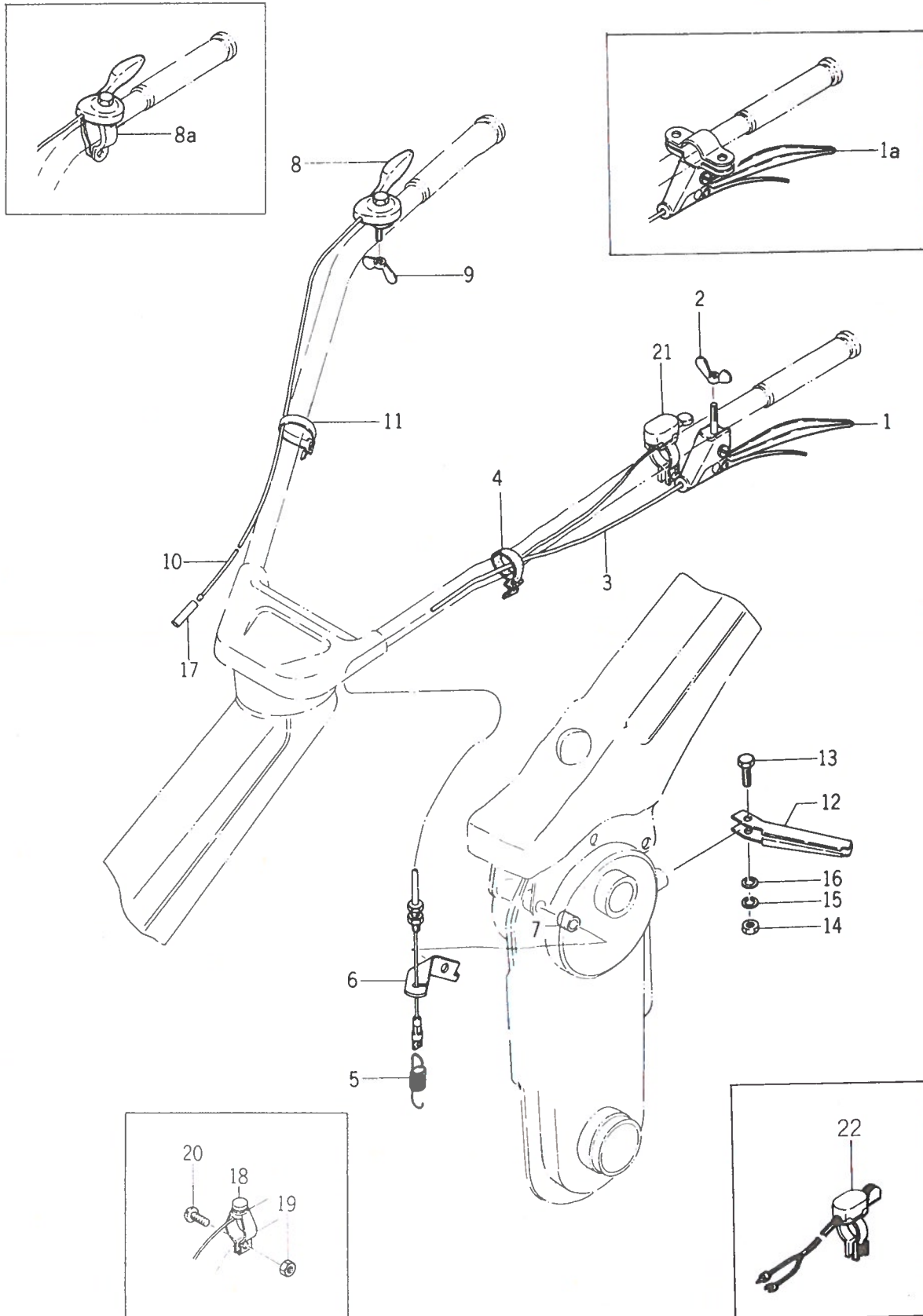


Ref No. Réf N°.	Parts No. Pièces N°.	Description Désignation	Model & Q'ty Model & Quant	Remarks Remarques
12- 1	1350-301-1000-0	FRAME, HANDLE Age	1	No. 1-18860
12- 1a	1350-301-1001-0	FRAME, HANDLE Age	1	No. 18861-
12- 2	1353-951-0021-0	MARK, MODEL A Plaquette	1	
12- 3	V29120-200060	RIVET Rivet	2	
12- 4	1350-301-0010-0	BRACKET, HANDLE Support	1	
12-4-1	1353-301- 0010-0	BRACKET, HANDLE Support	1	for 4-cycle type
12- 5	V20126-080550	BOLT/M8×55 Vis	2	
12- 6	V40116-000080	WASHER, SP/M8 Rondelle frein	3	
12- 7	V30526-000080	NUT/M8 Ecrou	3	
12- 8	V20126-080800	BOLT/M8×80 Vis	1	
12- 9	1350-301-2000-0	WASHER/25×54 Rondelle	1	
12-10	1350-301-3000-0	SCREW, HANDLE SET Manivelle	1	
12-11	1350-301-0020-0	BELT, CUSHION Cale	1	
12-12	1350-311-1000-0	HANDLE Mancheron	1	No. 1-26910
12-12a	1350-311-1001-0	HANDLE Mancheron	1	No. 26911-
12-13	1379-311-0020-0	GRIP, HANDLE Poignee	2	
12-14	V41326-001200	WASHER/M12 Rondelle	1	
12-15	V40116-001200	WASHER, SP/M12 Rondelle frein	1	
12-16	V32016-001200	NUT/M12 P1.5 Ecrou	1	No. 1-18860
12-16a	V32116-001200	NUT, SLOTTED Ecrou a creneaux	1	No. 18861-
12-17	V50015-300300	PIN, SPLIT/3×30 Goupille fendue	1	
12-18	1350-311-0020-0	PIN Axe	1	
12-19	1350-311-0030-0	SPRING, PRESS/38 Ressort	1	
12-20	1407-117-0031-0	KNOB, LEVER/31 Pommeau	1	
12-21	1350-311-0040-0	COVER, HANDLE Couvercle	1	
12-22	V11116-600100	SCREW/M6×10 Vis	2	
12-23	V40116-000600	WASHER, SP/M6 Rondelle frein	2	
12-24	V41316-000600	WASHER/M6 Rondelle	2	
12-25	1324-957-0120-0	MARK Plaquette	1	
12-26	1331-954-0060-0	MARK Etiquette	1	★ } for 2-cycle type
12-27	1331-952-0070-0	MARK, SWITCH Etiquette	1	
12-28	4114-606-0030-0	MARK, ISO Etiquette	1	Ⓧ

Fig. 13

CONTROL SYSTEM

Commandes

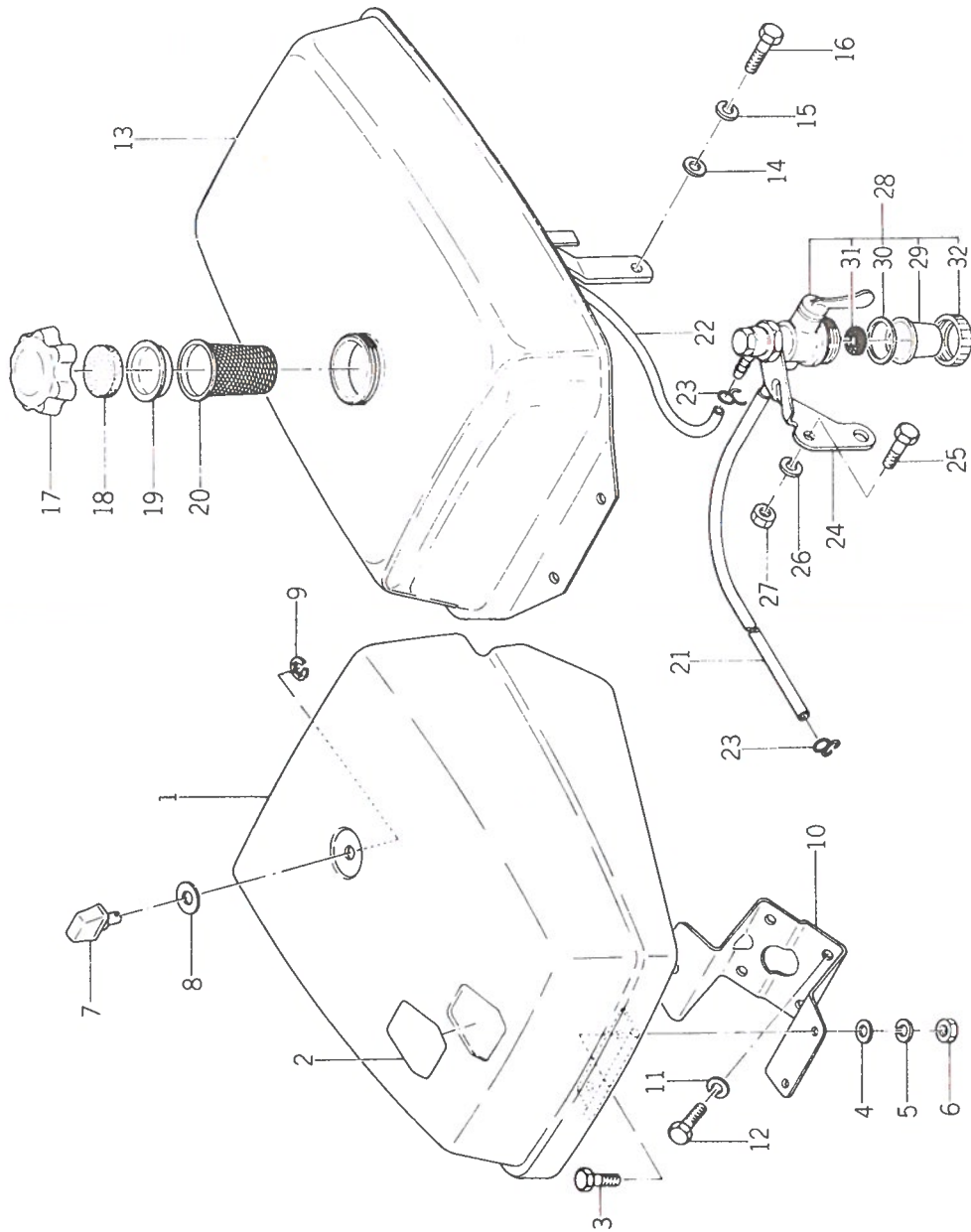




Ref No. Réf N°.	Parts No. Pièces N°.	Description Désignation	Model & Q'ty Modél & Quant	Remarks Remarques
13- 1	1350-400-0510-0	LEVER, CLUTCH ASSY Poignée ensemble	1	
13- 1a	1350-401-2000-0	LEVER, CLUTCH ASSY Poignée ensemble	1	
13- 2	V37016-000600	·NUT, WING/M6 Ecrou a oreilles	1	
13- 3	1349-401-0010-0	WIRE, CLUTCH Cable d'embrayage	1	No. 1-5600
13- 3a	1350-401-0040-0	WIRE, CLUTCH Cable d'embrayage	1	No. 5601-
13- 4	1315-621-0140-0	BAND/RUBBER Sangle	1	
13- 5	1325-401-0090-0	SPRING, MAIN CLUTCH Ressort	1	
13- 6	1350-401-0020-0	STAY, TENSION Equerre d'arret	1	
13- 7	1350-401-0030-0	PIPE/14 Tubulure	1	
13- 8	1350-400-0520-0	LEVER, THROTTLE ASSY Manette des gaz	1	
13- 8a	1379-402-2000-0	LEVER, THROTTLE ASSY Manette des gaz	1	
13- 9	V37016-000600	·NUT, WING/M6 Ecrou a oreilles	1	
13-10	1353-402-0010-0	WIRE, THROTTLE Cable d'accelerateur	1	
13-11	1376-402-0030-0	BAND, WIRE/140 Sangle	1	
13-12	1350-403-0010-0	LEVER, SHIFT Lever de changement	1	
13-13	V20026-060220	BOLT/M6 × 22 Vis	1	
13-14	V30026-000600	NUT/M6 Ecrou	1	
13-15	V40116-000600	WASHER, SP/M6 Rondelle frein	1	
13-16	V41326-001200	WASHER, PL/M12 Rondelle	1	
13-17	V73506-090200	PIPE/VINYL Chambre	1	
13-18	1353-600-0520-0	BUTTON, STOP ASSY Bouton d'arret	1	} for 2-cycle type
13-19	V30026-000300	·NUT/M3 Ecrou	1	
13-20	V11116-300120	·SCREW/M3 × 12 Vis	1	* } for 4-cycle type
13-21	1359-621-0020-0	SWITCH, STOP Interrupteur	1	
13-22	1353-651-2000-0	SWITCH, STOP ASSY	1	

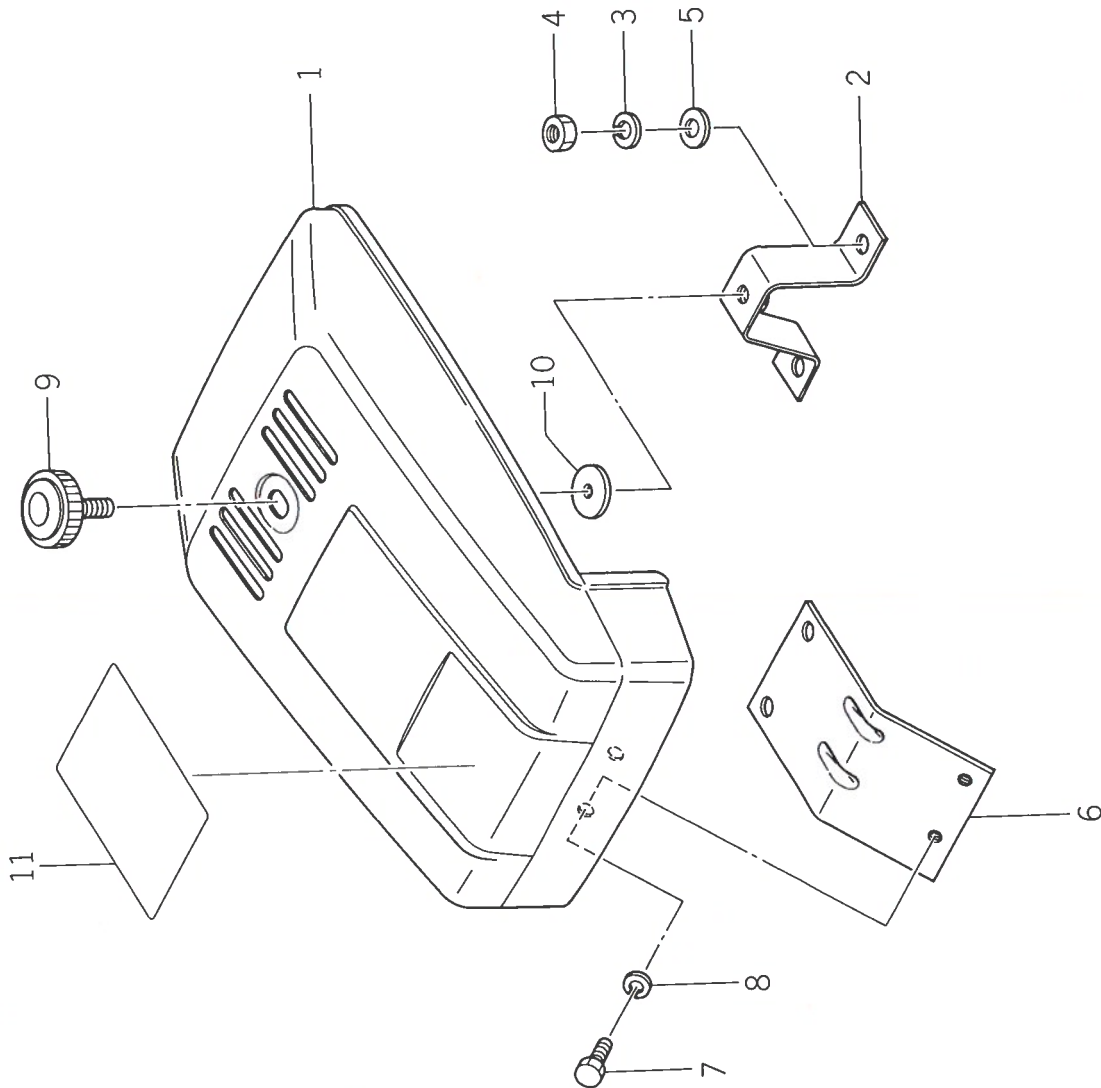
Fig. 14

FRONT COVER AND FUEL SYSTEM  
Reservoir & capot



Ref No. Réf N°.	Parts No. Pièces N°.	Description Désignation	Model & Qty Model & Quant	Remarks Remarques
14- 1	1353-601-1000-0	COVER, F. Capot	1	
14- 2	1329-902-0030-0	MARK Etiquette	1	
14- 3	V20026-060140	BOLT/M6 × 14 Vis	2	
14- 4	V41316-000600	WASHER, PL/M6 Rondelle	2	
14- 5	V40116-000600	WASHER, SP/M6 Rondelle frein	2	
14- 6	V30026-000600	NUT/M6 Ecrou	2	
14- 7	1338-301-4000-0	KNOB, SET Bouton de capot	1	
14- 8	1325-601-0050-0	WASHER Rondelle d'arrêt	1	
14- 9	V71024-000600	RING, SNAP/E6 Collet d'axe	1	
14-10	1353-601-2000-0	BRACKET, F-COVER Calandre	1	
14-11	V40116-000600	WASHER, SP/M6 Rondelle frein	4	
14-12	V20026-060120	BOLT/M6 × 12 Vis	4	
14-13	1353-606-1000-0	TANK, FUEL Reservoir	1	
14-14	V41316-000600	WASHER, PL/M6 Rondelle	2	
14-15	V40116-000600	WASHER, SP/M6 Rondelle frein	2	
14-16	V20026-060160	BOLT/M6 × 16 Vis	2	
14-17	1350-606-0020-0	CAP, TANK Bouchon de reservoir	1	
14-18	1350-606-0050-0	ELEMENT, CAP Pastille filtrante	1	
14-19	1350-606-0060-0	INNER, CAP Cuvette de pastille	1	
14-20	1350-606-0030-0	FILTER, FUEL Filtre de carburant	1	
14-21	V73505-082350	PIPE/VINYL 5 × 8 × 235 Conduit	1	
14-22	V73505-081900	PIPE/VINYL 5 × 8 × 190 Conduit	1	
14-23	1317-606-0100-0	RING, SNAP Collier	4	
14-24	1353-606-0010-0	STAY, STRAINER Support	1	
14-25	V20026-060160	BOLT/M6 × 16 Vis	1	
14-26	V40116-000600	WASHER, SP/M6 Rondelle frein	1	
14-27	V30026-000600	NUT/M6 Ecrou	1	
14-28	1353-600-0510-0	STRAINER, FUEL ASSY Robinet decanteur	1	
14-29	1353-606-0050-0	·CUP Bol	1	
14-30	1353-606-0060-0	·PACKING, FILTER Joint	1	
14-31	1353-606-0070-0	·NET, FILTER Filtre	1	
14-32	1353-606-0040-0	·RETAINER Ecrou annulaire	1	

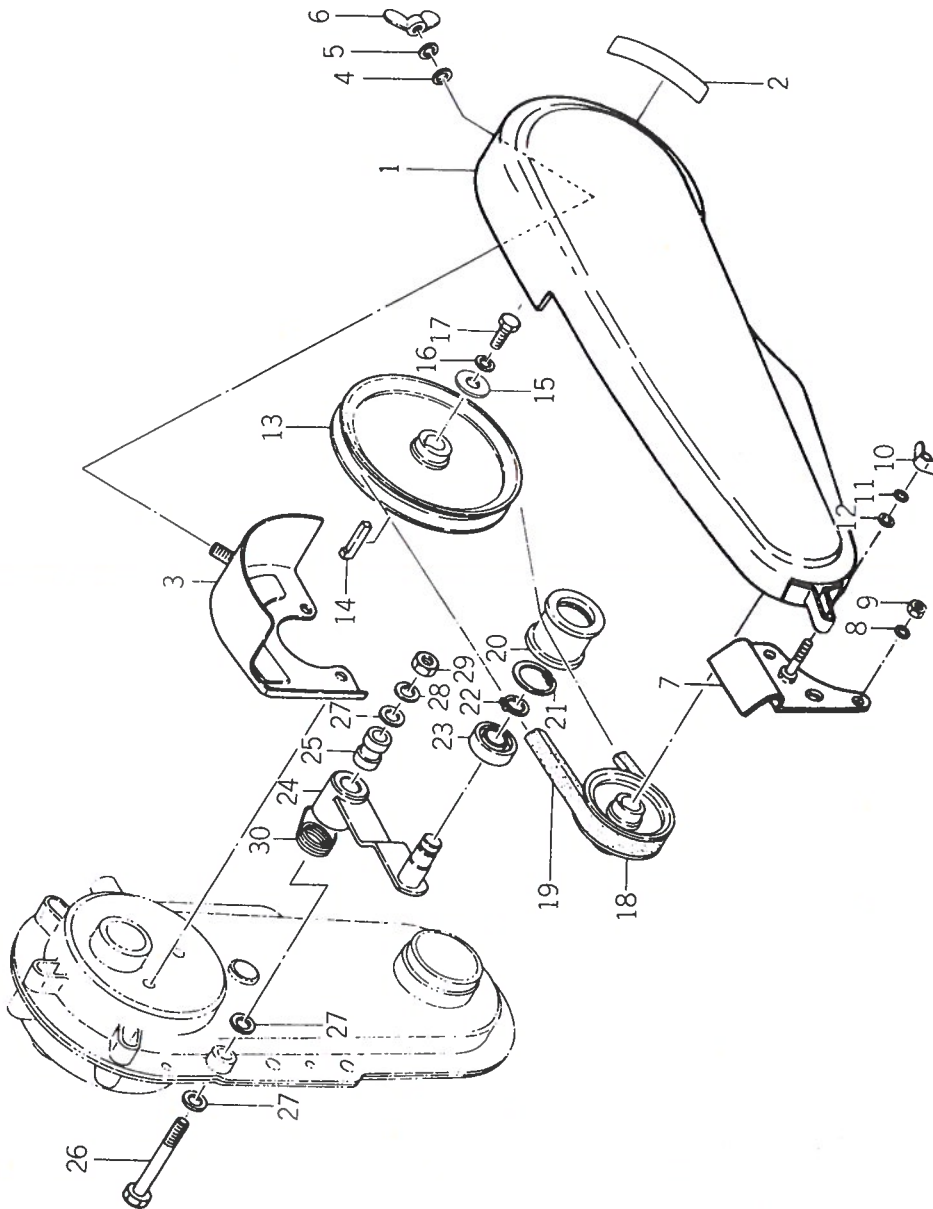
Fig. 14A BONNET (4-cycle type)  
Systeme d'entrainement



Ref No. Réf N°.	Parts No. Pièces N°.	Description Désignation	Model & Q'ty Modél & Quant	Remarks Remarques
14A-1	1353-602-2000-0	BONNET Capot	1	
14A-2	1353-602-2100-0	STAY, BONNET Calandre	1	
14A-3	V401-160-0080-0	WASHER, SP/M8 Rondelle frein	2	
14A-4	V300-260-0080-0	NUT/M8 Ecrrou	2	
14A-5	V413-160-0080-0	WASHER/M8 Rondelle	3	
14A-6	1353-602-2200-0	STAY, HINGE Support	1	
14A-7	V200-260-6010-0	BOLT/M6×10 Vis	2	
14A-8	V401-160-0060-0	WASHER, SP/M6 Rondelle frein	2	
14A-9	1376-601-0030-0	KNOB, SET/35 Bouton de capot	1	
14A-10	1352-601-0030-0	SUPPORT Support	1	
14A-11	1353-953-0010-0	MARK, MASCOT Etiquette	1	

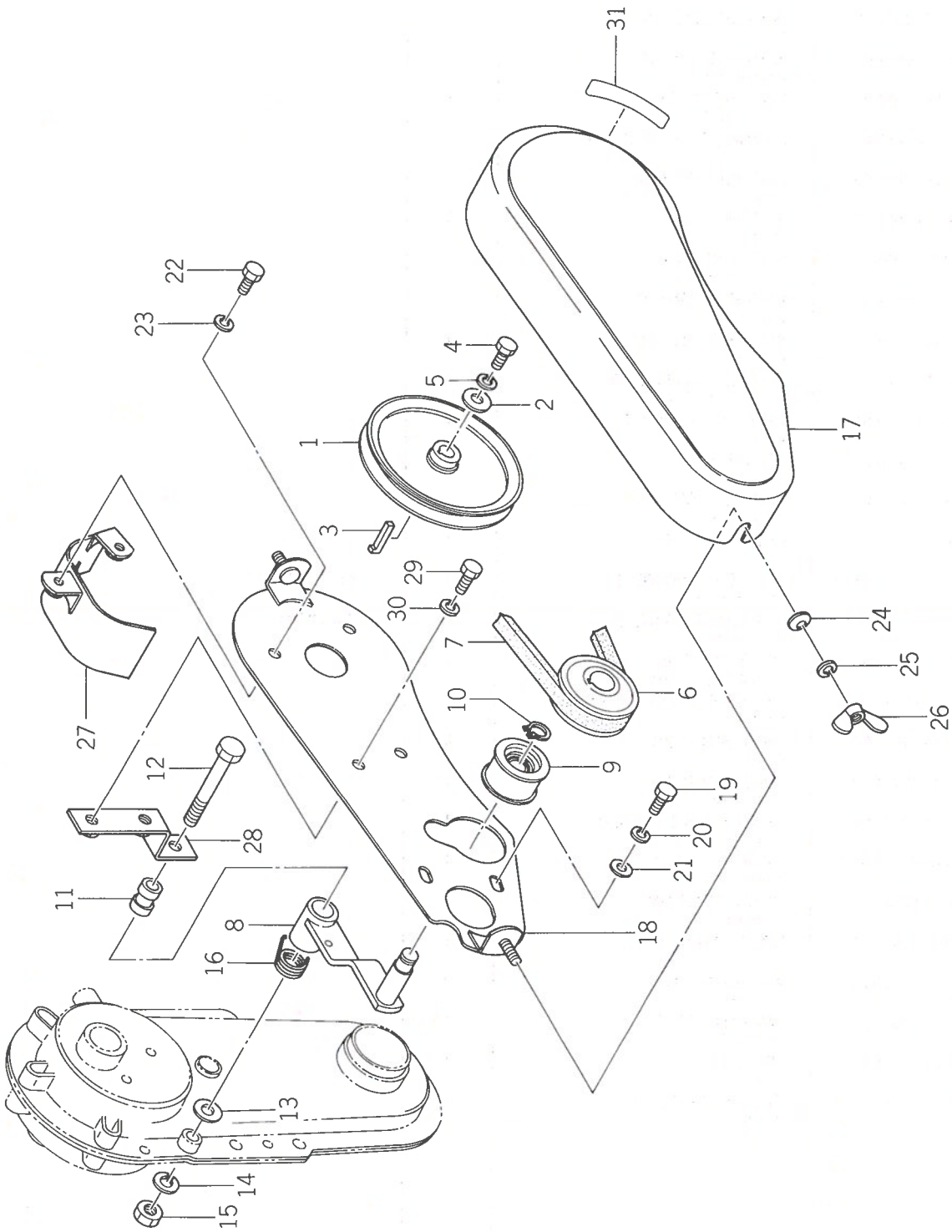
Fig. 15

BELT DRIVE  
Systeme d'entrainement



Ref No. Réf N°.	Parts No. Pièces N°.	Description Désignation	Model & Qty Modél & Quant	Remarks Remarques
15- 1	1353-611-1000-0	COVER, BELT Carter de courroies	1	
15- 2	1353-952-0020-0	MARK Etiquette	1	
15- 3	1350-611-1000-0	STAY, BELT COVER Support	1	
15- 4	V41316-000800	WASHER, PL/M8 Rondelle	1	
15- 5	V40116-000800	WASHER, SP/M8 Rondelle frein	1	
15- 6	V37016-000800	NUT, WING/M8 Ecrou a oreilles	1	
15- 7	1353-611-2000-0	BRACKET, BELT COVER Support	1	
15- 8	V40116-000600	WASHER, SP/M6 Rondelle	2	
15- 9	V30026-000600	NUT/M6 Ecrou	2	
15-10	V37016-000800	NUT, WING/M8 Ecrou a oreilles	1	
15-11	V40116-000800	WASHER, SP/M8 Rondelle frein	1	
15-12	V41316-000800	WASHER PL/M8 Rondelle	1	
15-13	1350-201-1000-0	PULLEY, MAIN SHAFT Poulie trapezoidale	1	
15-14	1329-201-0030-0	KEY, MAIN SHAFT Clavette	1	
15-15	1305-701-0060-0	WASHER Rondelle	1	
15-16	V40116-000600	WASHER, SP/M6 Rondelle frein	1	
15-17	V20026-060160	BOLT/M6 × 16 Vis	1	
15-18	1353-201-1000-0	PULLEY, ENGINE/57 Poulie motrice	1	No. 1-10000
15-18a	1353-201-0010-0	PULLEY, ENGINE/57 Poulie motrice	1	No. 10001-
15-19	V81700-003600	BELT, V/SB36 Courroie trapezoidale	1	
15-20	1350-202-0010-0	PULLEY, TENSION/35 × 20 Galet tendeur	1	
15-21	V70514-003000	RING, SNAP/30 Collet d'axe	2	
15-22	V70414-001000	RING, SNAP/10 Collet d'axe	1	
15-23	V60015-062000	BEARING, RB/6202RS Roulement	1	
15-24	1350-202-1000-0	ARM, TENSION Tirant	1	
15-25	1350-202-0020-0	BUSH, TENSION Coussinet	1	
15-26	V20126-100850	BOLT/M10 × 85 Vis	1	
15-27	V41116-001000	WASHER/M10 Rondelle	2	
15-28	V40116-001000	WASHER, SP/M10 Rondelle frein	1	
15-29	V30026-001000	NUT/M10 Ecrou	1	
15-30	1350-202-0030-0	SPRING, RETURN Resort	1	

Fig. 15A BELT DRIVE (4-cycle type)  
Système d'entraînement

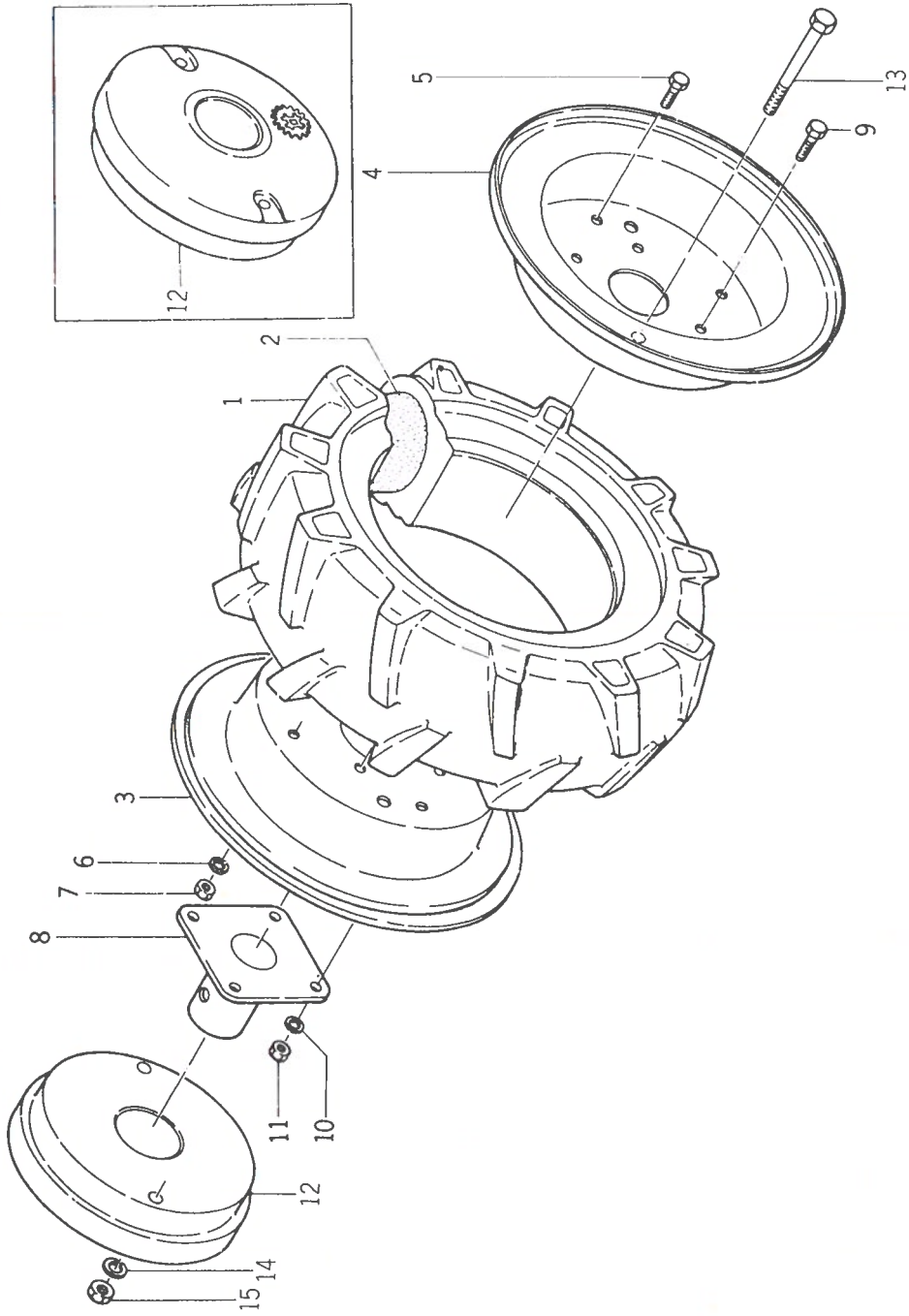




Ref No. Réf N°.	Parts No. Pièces N°.	Description Désignation	Model & Qty Modél & Quant	Remarks Remarques
15A-1	1350-201-1000-0	PULLEY, MAIN SHAFT/140 Poulie trapézoïdale	1	
15A-2	1305-701-0060-0	WASHER Rondelle	1	
15A-3	1329-201-0030-0	KEY Clavette	1	
15A-4	V200-260-6016-0	BOLT/M6×16 Vis	1	
15A-5	V401-160-0060-0	WASHER, SP/M6 Rondelle frein	1	
15A-6	1353-205-0010-0	PULLEY, ENGINE/57 Poulie matrice	1	
15A-7	V817-200-0360-0	BELT, V/SB36 Courroie trapézoïdale	1	
15A-8	1353-206-2000-0	ARM, TENSION Tirant	1	
15A-9	1378-202-2000-0	PULLEY, TENSION ASSY Galet tendeur	1	
X 15A-10	V404-140-0120-0 V205-140-0120-0	RING, SNAP/C12 Collet daxe	1	(A) info no. 83-05 (2/2) Jan 11, '83
15A-11	1350-202-0020-0	BUSH, TENSION Cousinnet	1	
15A-12	V201-261-0085-0	BOLT/M10×85 Vis	1	
15A-13	V411-260-0100-0	WASHER/M10 Rondelle	1	
15A-14	V401-160-0100-0	WASHER, SP/M10 Rondelle frein	1	
15A-15	V300-260-0100-0	NUT/M10 Erou	1	
15A-16	1350-202-0030-0	SPRING, RETURN Ressort	1	
15A-17	1353-612-2000-0	COVER, BELT A Carter de courroies	2	
15A-18	1353-612-2100-0	COVER, BELT B Carter de courroies	1	
15A-19	V201-260-8016-0	BOLT/M8×16 Vis	2	
15A-20	V401-160-0080-0	WASHER, SP/M8 Rondelle frein	2	
15A-21	V413-160-0080-0	WASHER/M8 Rondelle	2	
15A-22	V201-260-8016-0	BOLT/M8×16 Vis	2	
15A-23	V401-160-0080-0	WASHER, SP/M8 Rondelle frein	2	
15A-24	1352-616-0020-0	WASHER, CONE Rondelle	2	
15A-25	V401-160-0080-0	WASHER, SP/M8 Rondelle frein	2	
X 15A-26	V340-160-0080-0 V370-160-0080-0	NUT, WING/M8 Erou à oreilles	2	(A) info no. 83-05 (2/2) Jan 11, '83
15A-27	1353-612-2200-0	COVER, BELT C Carter de courroies	1	
X 15A-28	<del>1353-612-2300-0</del>	STAY, BELT COVER Support	1	(B) info no. 83-05 (1/2) Jan 11, '83
15A-29	V201-260-8012-0	BOLT/M8×12 Vis	2	
15A-30	V401-160-0080-0	WASHER, SP/M8 Rondelle frein	2	
15A-31	1353-952-0020-0	MARK, CHANGE Étiquette	1	

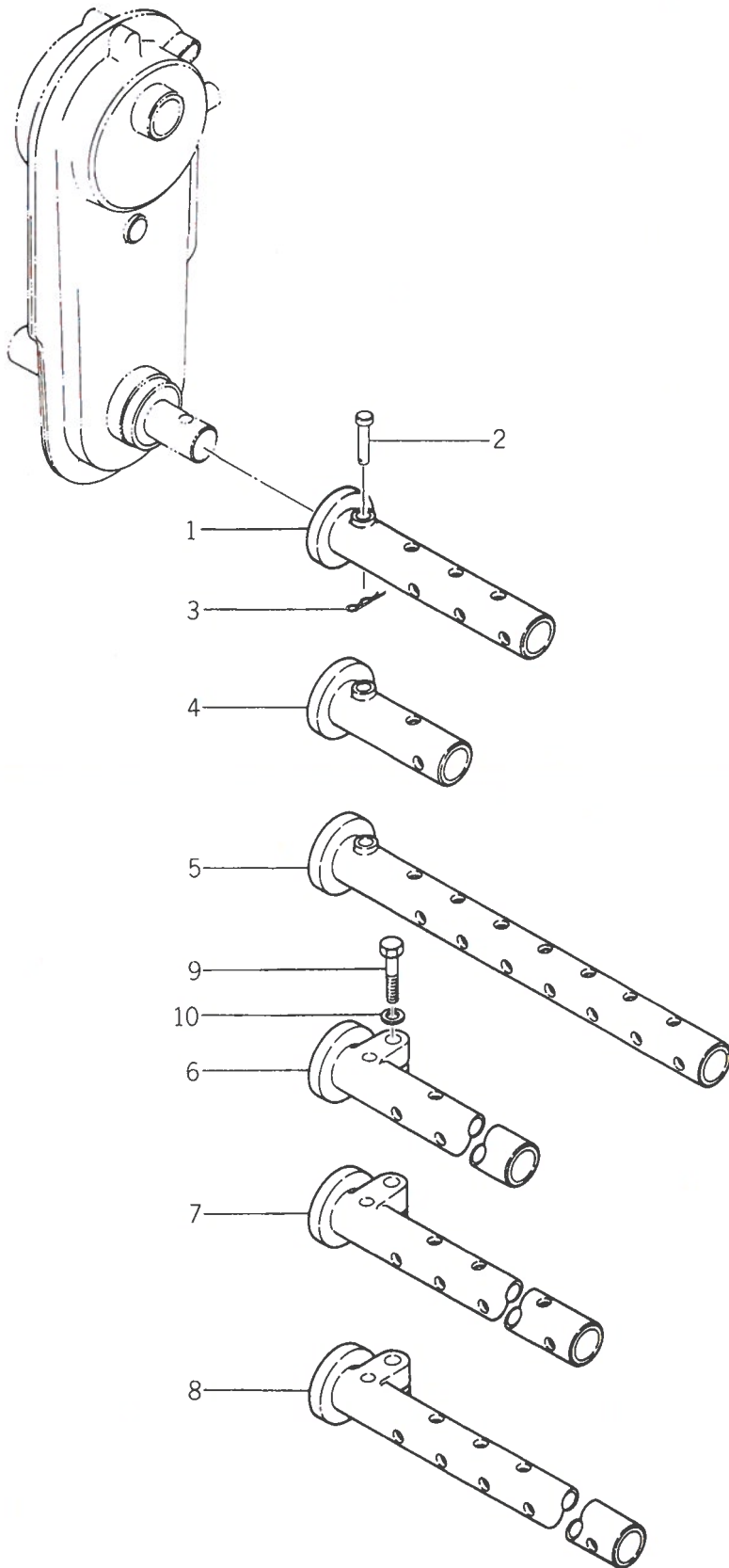
Fig. 16

WHEEL  
Roues



Ref No. Réf N°.	Parts No. Pièces N°.	Description Désignation	Model & Q'ty Modél & Quant	Remarks Remarques
16- 0-1	1329-200-9030-0	TIRE, LH ASSY Roue G. ensemble	1	★
16- 0-2	1329-200-9040-0	TIRE, RH ASSY Roue D. ensemble	1	★
16- 1	V88202-400070	• TIRE/4.00-7 2PR Pneu	2	★
16- 2	V88300-400070	• TUBE/4.00-7 Chambre a air	2	★
16- 0-3	1329-200-9020-0	• DRUM, WHEEL Jante	2	★
16- 3	1329-241-0020-0	• • DRUM, WHEEL Jante	2	★
16- 4	1329-241-0030-0	• • DRUM, WHEEL Jante	2	★
16- 5	V20126-080160	• • BOLT/M8 × 16 Vis	8	★
16- 6	V40116-000800	• • WASHER, SP/M8 Rondelle frein	8	★
16- 7	V30020-000800	• • NUT/M8 Erou	8	★
16- 8	1329-241-6000-0	FLANGE, WHEEL BOSS Moyeu	2	★
16- 9	V20126-080180	BOLT/M8 × 18 Vis	8	★
16-10	V40116-000800	WASHER, SP/M8 Rondelle frein	8	★
16-11	V30026-000800	NUT/M8 Erou	8	★
16-12	1329-931-0020-0	WEIGHT, WHEEL Masse pour roue	2	★
16-13	V20126-100950	BOLT/M10 × 95 Vis	4	★
16-14	V40116-001000	WASHER, SP/M10 Rondelle frein	4	★
16-15	V30026-001000	NUT/M10 Erou	4	★

✓  
Fig. 17 WHEEL PIPE  
Tube rallonge

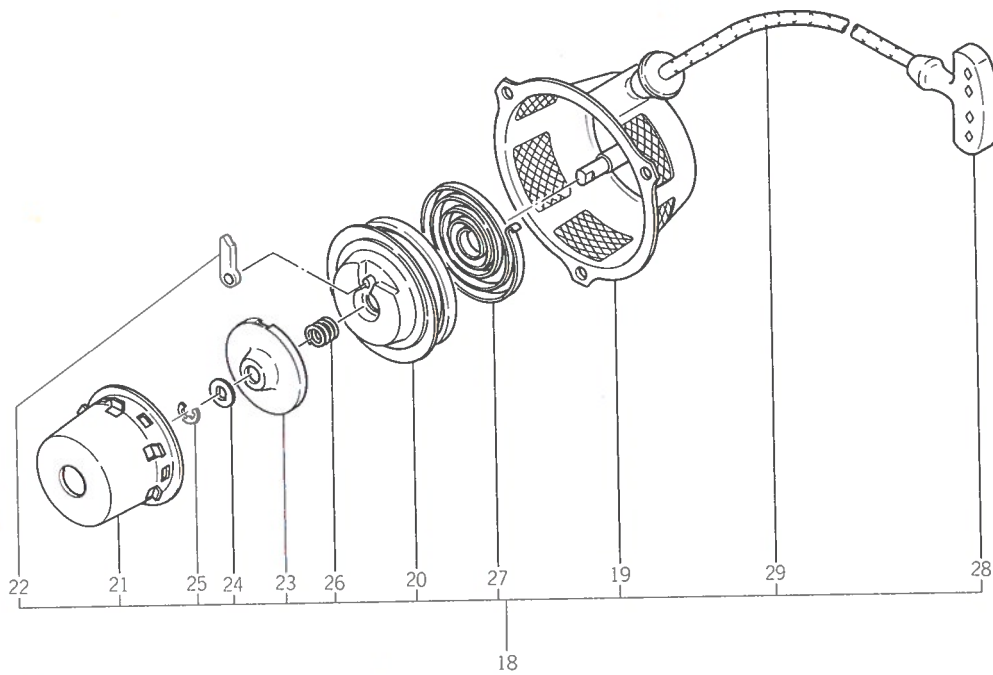
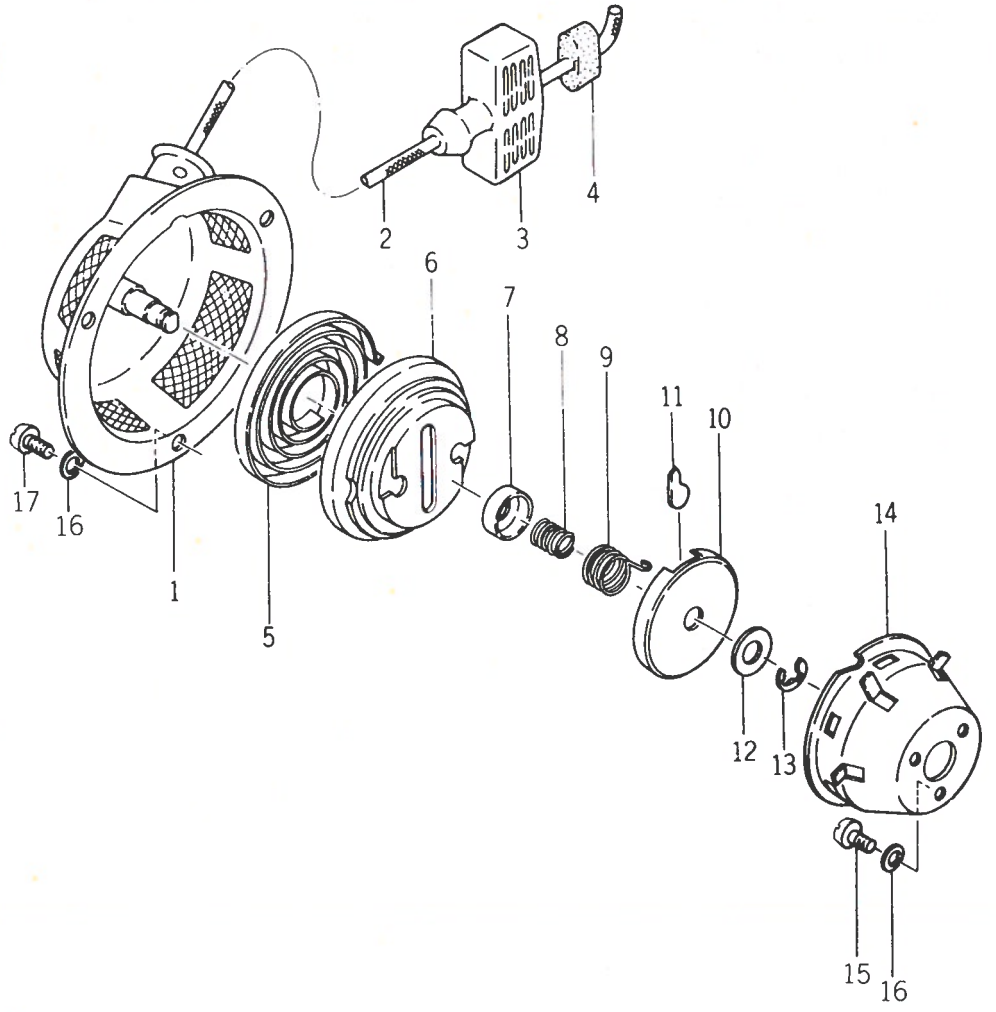


Ref No. Réf N°.	Parts No. Pièces N°.	Description Désignation	Model & Q'ty Modél & Quant	Remarks Remarques
17- 1	1329-241-4000-0	PIPE, WHEEL Tube rallonge	2	★
17- 2	1310-241-0030-0	PIN, HEADED A Goupille	4	
17- 3	1305-241-0010-0	PIN, HAIR Attache beta	4	
17- 4	1329-241-3000-0	PIPE, WHEEL Tube rallonge	2	★
17- 5	1329-241-5000-0	PIPE, WHEEL Tube rallonge	2	★
17- 6	1331-253-1000-0	PIPE, WHEEL Tube rallonge	2	★
17- 7	1331-253-2000-0	PIPE, WHEEL Tube rallonge	2	★
17- 8	1331-253-3000-0	PIPE, WHEEL Tube rallonge	2	★
17- 9	V20126-120500	BOLT/M12× 50 Vis	2	★
17-10	V40116-001200	WASHER, SP/M12 Rondelle frein	2	★

Fig. 18

RECOIL STARTER

Lanceur

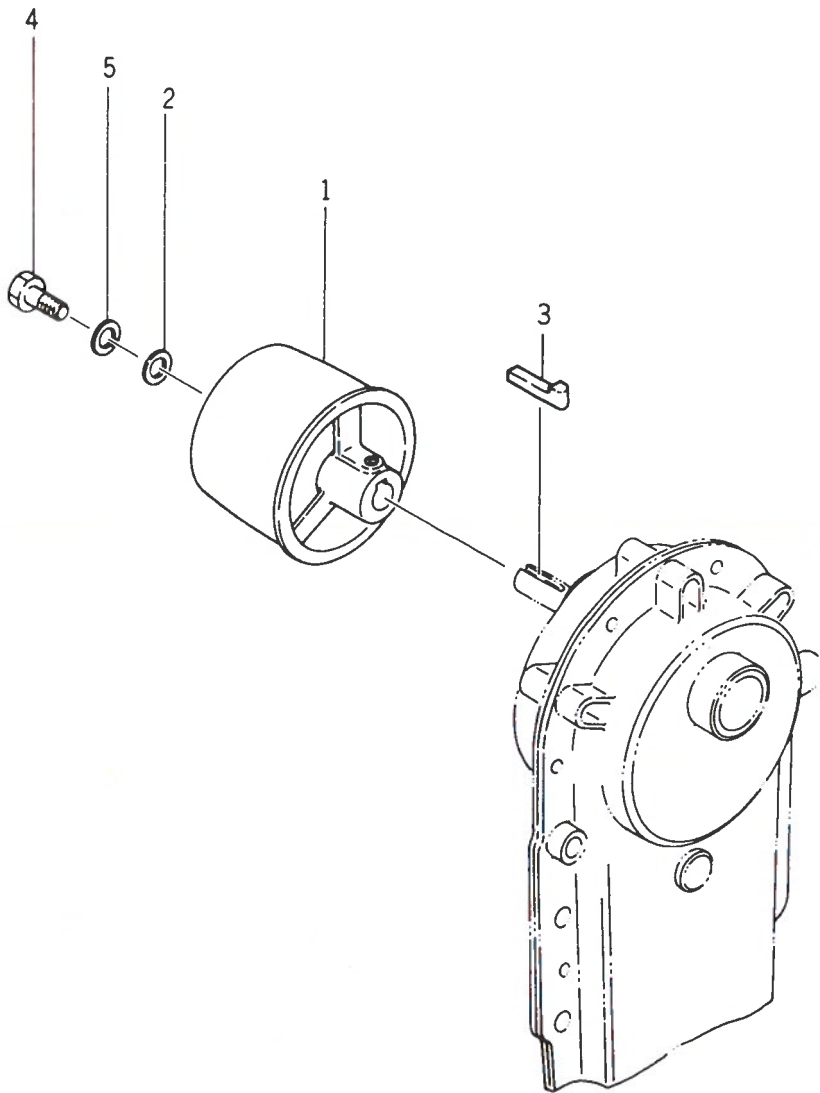


Ref No. Réf N°.	Parts No. Pièces N°.	Description Désignation	Model & Q'ty Modél & Quant	Remarks Remarques	
18- 0-1	1353-100-0520-0	STARTER, RECOIL ASSY Lanceur complet	1	#1~29660	
18- 0-1a	1353-100-0521-0	STARTER, RECOIL ASSY Lanceur complet	1	#29661~047680	
18- 1	1345-121-0020-0	·BODY, CASE Carter de lanceur	1	}	
18- 2	1345-121-0090-0	·ROPE Cordon	1		
18- 3	1353-121-0020-0	·HANDLE Poignée	1		
18- 4	1345-121-0110-0	·STOPPER, ROPE Butée de câble	1		
18- 5	1345-121-0050-0	·SPRING, SPIRAL Ressort spirale	1		
18- 6	1345-121-0030-0	·BODY, CAM Bobine de revindage	1		~#047680
18- 7	1345-121-0150-0	·COVER, SPRING Rondelle	1		
18- 8	1345-121-0070-0	·SPRING Ressort	1		
18- 9	1345-121-0140-0	·SPRING, RETURN Ressort	1		
18-10	1345-121-0060-0	·PLATE Disque d'encliquetage	1		
18-11	1345-121-0040-0	·RATCHET Cliquet	2		
18-12	1345-121-0080-0	·WASHER B Rondelle	2		
18-13	V71020-000600	·RING, SNAP/E6 Collet d'axe	1		
18-14	1345-121-0120-0	·PULLEY, STARTER Poulie d'entraînement	1		#1~29660
18-14a	1345-121-0121-0	·PULLEY, STARTER Poulie d'entraînement	1	#29661~047680	
18-15	V11116-600100	SCREW/M6×10 Vis	3	}	
18-16	V40116-000060	WASHER, SP/M6 Rondelle frein	6		
18-17	V11116-600080	SCREW/M6×8 Vis	3		
18-18	1353-121-2000-0	STARTER, RECOIL ASSY Lanceur complet	1		
18-19	1353-121-2010-0	·CASE, SUB Carter de lanceur	1		
18-20	1353-121-2020-0	·REEL, SUB Bobine de revindage	1		
18-21	1353-121-2040-0	·PULLEY, ENGINE Poulie motrice	1		
18-22	1353-121-2050-0	·RATCHET Cliquet	1		#047681~
18-23	1353-121-2060-0	·GUIDE, RATCHET Palier primaire	1		
18-24	1353-121-2070-0	·WASHER Rondelle	1		
18-25	1353-121-2080-0	·RING, SNAP E Collet d'axe	1		
18-26	1353-121-2090-0	·SPRING, COIL Ressort spirale	1		
18-27	1353-121-2110-0	·SPRING, FLAT Ressort	1		
18-28	1372-121-2240-0	·HANDLE A Poignée	1		
18-29	1353-121-2120-0	·ROPE Cordon	1		

*cd md*

Fig. 19

POWER TAKE OFF  
Poulie de prise de force

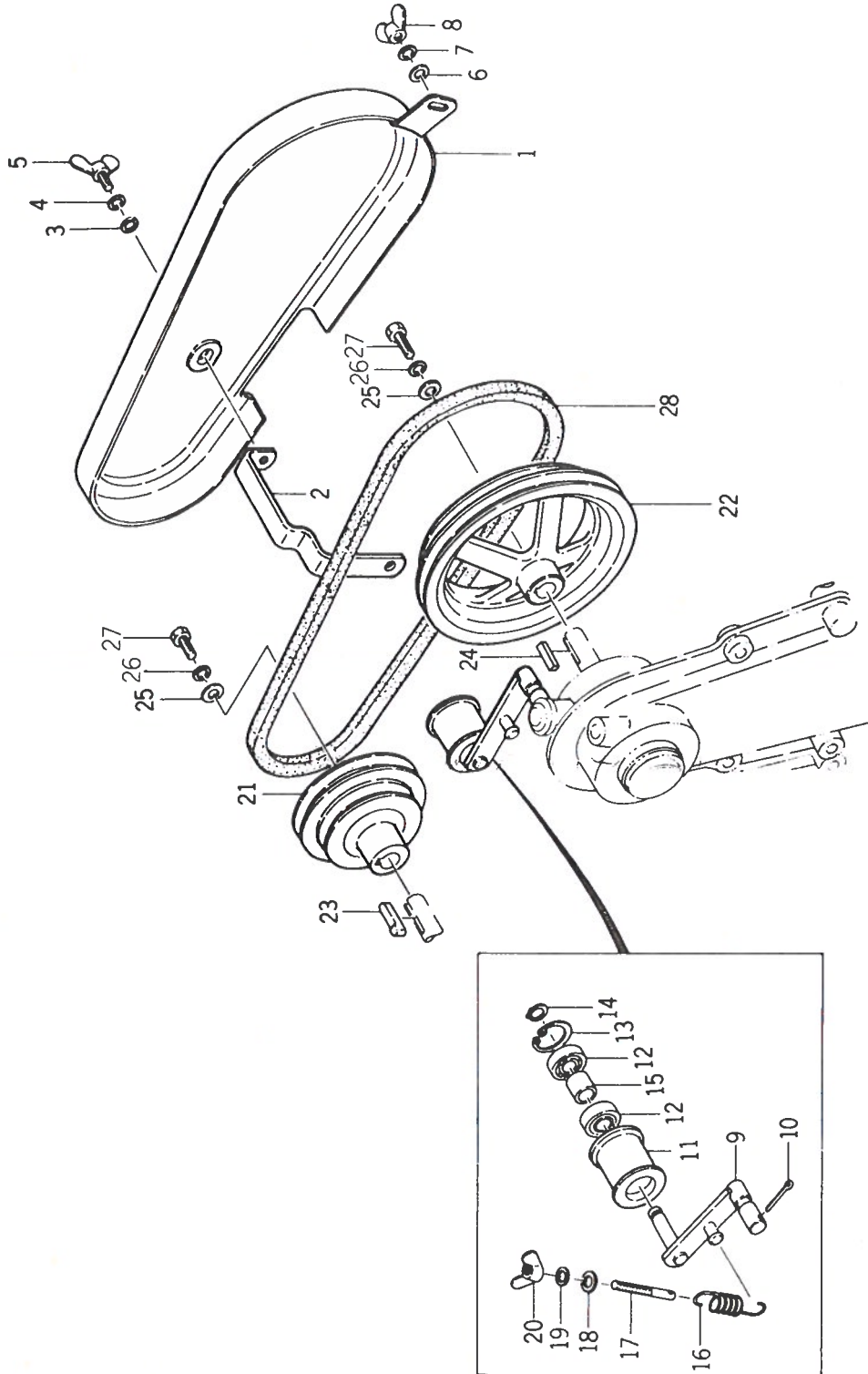




Ref No. Réf N°.	Parts No. Pièces N°.	Description Désignation	Model & Q'ty Model & Quant	Remarks Remarques
19- 1	1350-917-0010-0	PULLEY/115 Poulie	1	
19- 2	1305-701-0060-0	WASHER Rondelle	1	
19- 3	1329-201-0030-0	KEY, MAIN SHAFT PULLEY Clavette	1	
19- 4	V20026-060160	BOLT/M6×16 Vis	1	
19- 5	V40116-000600	WASHER, SP/M6 Rondelle frein	1	

after  
no need.

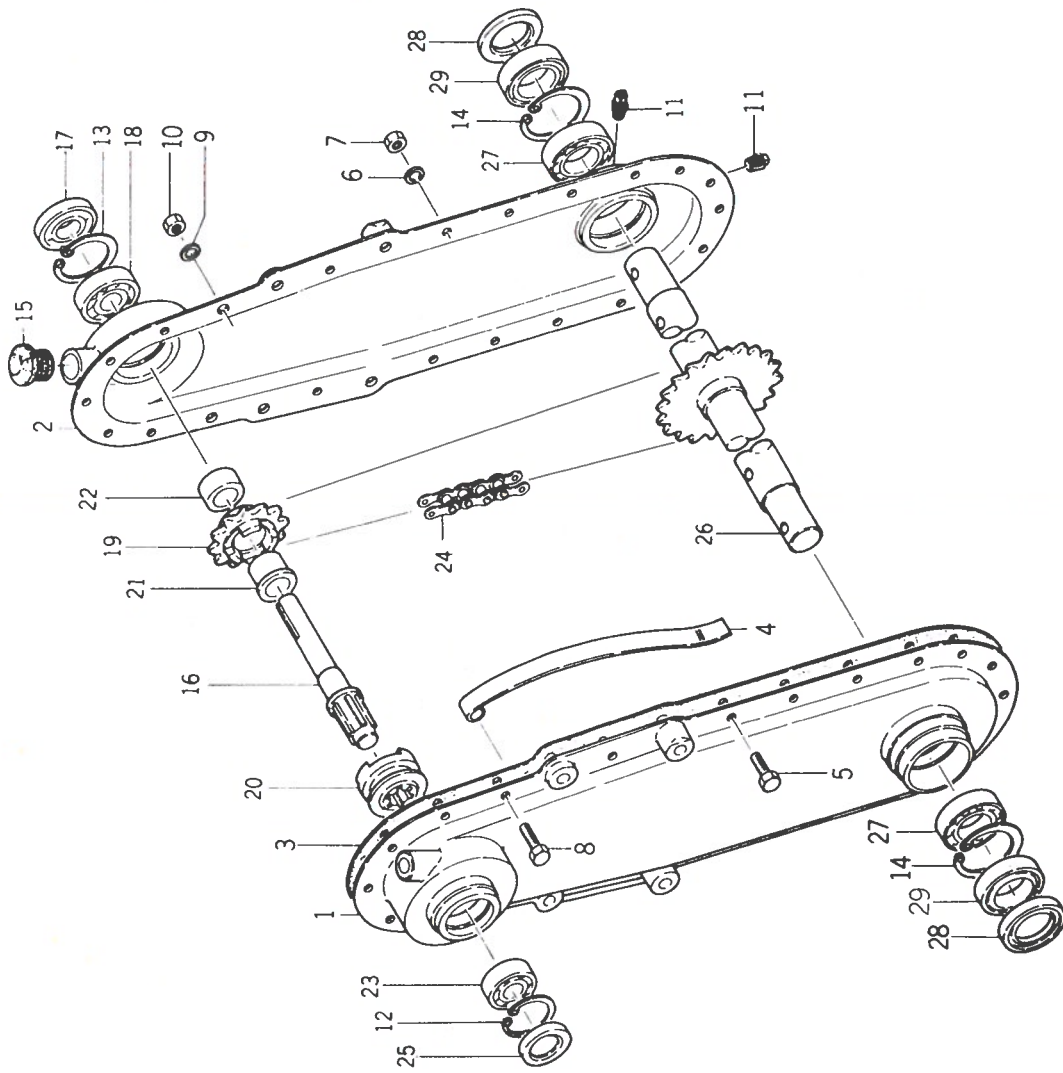
Fig. 20 ROTARY BELT DRIVE  
Courvoie intermediaire



Ref No. Réf N°.	Parts No. Pièces N°.	Description Désignation	Model & Q'ty Modél & Quant	Remarks Remarques
20- 1	1350-701-1000-0	COVER, BELT Carter de courroie	1	★
20- 2	1350-701-0010-0	BRACKET, BELT COVER Support de carter	1	★
20- 3	V41316-000800	WASHER, PL/M8 Rondelle	1	★
20- 4	V40116-000800	WASHER, SP/M8 Rondelle frein	1	★
20- 5	V27016-080120	BOLT, WING/M8×12 Vis a oreilles	1	★
20- 6	V41316-000800	WASHER, PL/M8 Rondelle	1	★
20- 7	V40116-000800	WASHER, SP/M8 Rondelle frein	1	★
20- 8	1323-721-0070-0	NUT, WING/M8 Ecroû a oreilles	1	★
20- 9	1349-701-3000-0	ARM, TENSION Tirant	1	★
20-10	V50015-300250	PIN, SPLIT/3×25 Goupille fendue	1	★
20-11	1329-202-0011-0	PULLEY, TENSION/40×43 Galet tendeur	1	★
20-12	V60014-062010	BEARING, RB/6201RS Roulement	2	★
20-13	V70514-003200	RING, SNAP/32 Collet d'axe	1	★
20-14	V70414-001200	RING, SNAP/12 Collet d'axe	1	★
20-15	1329-202-0030-0	COLLAR, TENSION Collier	1	★
20-16	1325-401-0090-0	SPRING, MAIN CLUTCH Ressort	1	★
20-17	1349-701-0010-0	BOLT, TENSION Vis	1	★
20-18	V41316-000800	WASHER, PL/M8 Rondelle	1	★
20-19	V40116-000800	WASHER, SP/M8 Rondelle frein	1	★
20-20	1323-721-0070-0	NUT, WING/M8 Ecroû a oreilles	1	★
20-21	1350-701-0020-0	PULLEY, V/74-96 Poulie trapezoidale	1	★
20-22	1349-701-0030-0	PULLEY, V/160-180 Poulie trapezoidale	1	★
20-23	1329-201-0030-0	KEY, MAIN SHAFT Clavette	1	★
20-24	1329-917-0020-0	KEY, PULLEY Clavette	1	★
20-25	1337-701-0040-0	WASHER/7×21×3 Rondelle	2	★
20-26	V40116-000600	WASHER, SP/M6 Rondelle frein	2	★
20-27	V20026-060160	BOLT/M6×16 Vis	2	★
20-28	V81720-004000	BELT, V/SB40 Courroie trapezoidale	1	★

Fig. 21

ROTARY CHAIN CASE  
Transmission de rotobineuse

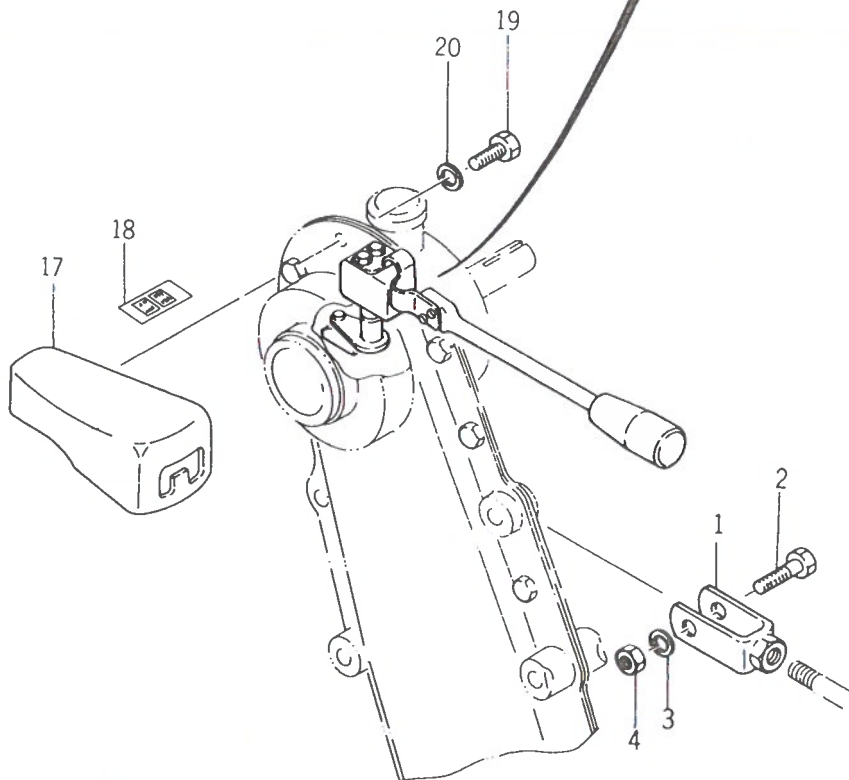
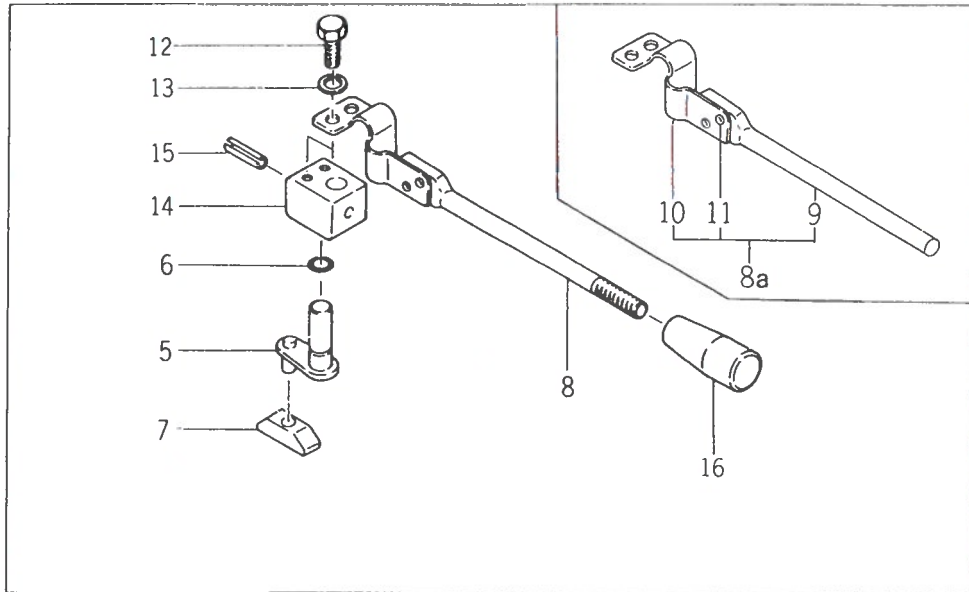


Ref No. Réf N°.	Parts No. Pièces N°.	Description Désignation	Model & Qty Modél & Quant	Remarks Remarques
21- 1	1349-706-1000-0	CASE, ROTARY CHAIN LH Demi carter G.	1	★
21- 2	1349-706-2000-0	CASE, ROTARY CHAIN RH Demi carter D.	1	★
21- 3	1349-706-0010-0	PACKING, CHAIN CASE Joint de carter	1	★
21- 4	1337-706-0020-0	TIGHTENER, CHAIN Linguet tendeur	1	★
21- 5	V20026-060120	BOLT/M6×12 Vis	16	★
21- 6	V40116-000600	WASHER, SP/M6 Rondelle frein	16	★
21- 7	V30026-000600	NUT/M6 Erou	16	★
21- 8	V20126-080160	BOLT/M8×16 Vis	4	★
21- 9	V40116-000800	WASHER, SP/M8 Rondelle frein	4	★
21-10	V30026-000800	NUT/M8 Erou	4	★
21-11	1326-706-0020-0	PLUG, DRAIN Bouchon de vidange	2	★
21-12	V70514-004000	RING, SNAP/40 Collet d'axe	1	★
21-13	V70514-004700	RING, SNAP/47 Collet d'axe	1	★
21-14	V70514-005500	RING, SNAP/55 Collet d'axe	2	★
21-15	1366-706-0010-0	CAP, OIL/23 Bouchon	1	★
21-16	1337-708-0010-0	SHAFT, ROTARY TOP Arbre superieur	1	★
21-17	V74012-047070	SEAL, OIL/SC20477 Bague d'etancheite	1	★
21-18	V60011-062040	BEARING, RB/6204 Roulement	1	★
21-19	1349-708-0010-0	SPROCKET/12T Pignon	1	★
21-20	1337-708-0030-0	CLUTCH, ROTARY Embrayage	1	★
21-21	1337-708-0040-0	BUSH, SPROCKET Coussinet	1	★
21-22	1337-708-0050-0	COLLAR/21×30×9 Entretoise	1	★
21-23	V60011-062030	BEARING, RB/6203 Roulement	1	★
21-24	1337-708-0060-0	CHAIN, ROLLER Chaîne	1	★
21-25	1337-708-0070-0	COVER, METAL Couvercle	1	★
21-26	1349-709-1000-0	SHAFT, ROTARY Arbre de fraises	1	★
21-27	V60011-060060	BEARING, RB/6006 Roulement	2	★
21-28	V74213-055050	SEAL, OIL/VC30555 Bague d'etancheite	2	★
21-29	V74413-055120	SEAL, OIL/TC305512 Bague d'etancheite	2	★

Fig. 22

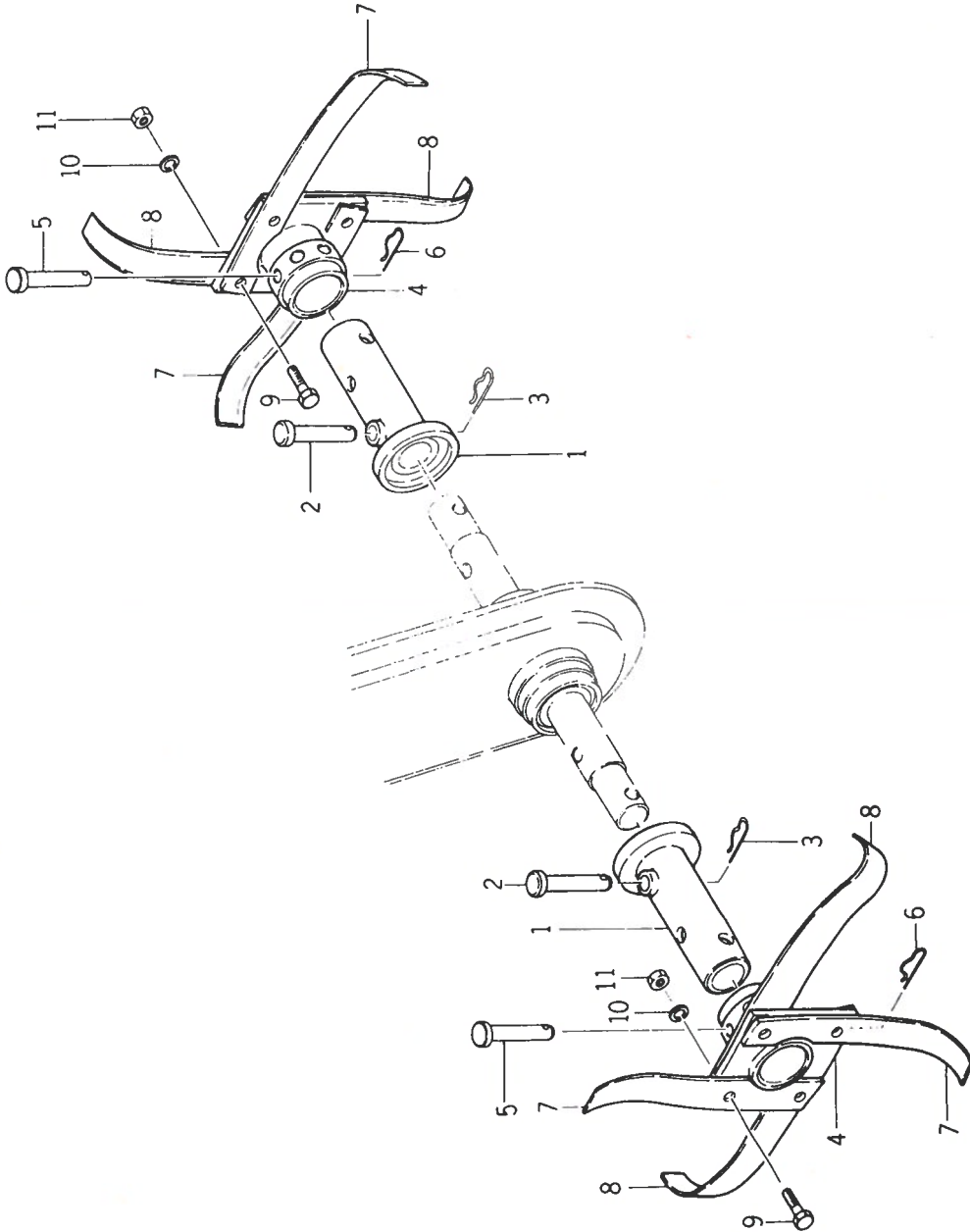
ROTARY SHIFTER

Embrayage de rotobineuse



Ref No. Réf N°.	Parts No. Pièces N°.	Description Désignation	Model & Qty Model & Quant	Remarks Remarques
22- 1	1337-706-3000-0	FORK Chape	1	★
22- 2	V20126-100360	BOLT/M10×36 Vis	1	★
22- 3	V40116-001000	WASHER, SP/M10 Rondelle frein	1	★
22- 4	V30026-001000	NUT/M10 Ecrou	1	★
22- 5	1337-706-4001-0	ROD, SHIFTER Selecteur	1	★
22- 6	V72010-190090	O-RING/P9 Joint torique	1	★
22- 7	1340-229-0020-0	SHIFTER, SIDE CLUTCH Flotteur	1	★
22- 8	1337-706-5001-0	LEVER, CLUTCH Lever d'embrayage	1	★ No. 1-18260
22- 8a	1337-706-5002-0	LEVER, CLUTCH Lever d'embrayage	1	★ } No. 18261-
22- 9	1337-706-5051-0	LEVER (C) Lever	1	
22-10	1337-706-5060-0	SPRING, PLATE Ressort	1	
22-11	V29010-300090	RIVET/3×9 Rivet	2	★
22-12	V20126-060100	BOLT/M6×10 Vis	2	★
22-13	V40116-000600	WASHER, SP/M6 Rondelle frein	2	★
22-14	1337-706-0030-0	BOSS/25×25 Bossage	1	★
22-15	V58014-040250	PIN, SPRING Goupille elastique	1	★
22-16	1338-401-0050-0	KNOB, LEVER/24×57 Poignee	1	★ No. 1-18260
22-16a	4106-105-3030-0	GRIP Poignee	1	★ No. 18261-
22-16b	2101-230-0010-0	GRIP Poignee	1	★ (A)
22-17	1337-706-6001-0	GUIDE, CLUTCH Guide de commande	1	★
22-18	1349-956-0080-0	MARK, ROTARY CLUTCH Repece	1	★
22-19	V20026-060140	BOLT/M6×14 Vis	2	★
22-20	V40116-000600	WASHER, SP/M6 Rondelle frein	2	★

Fig. 23 ROTARY PIPE  
Fraise

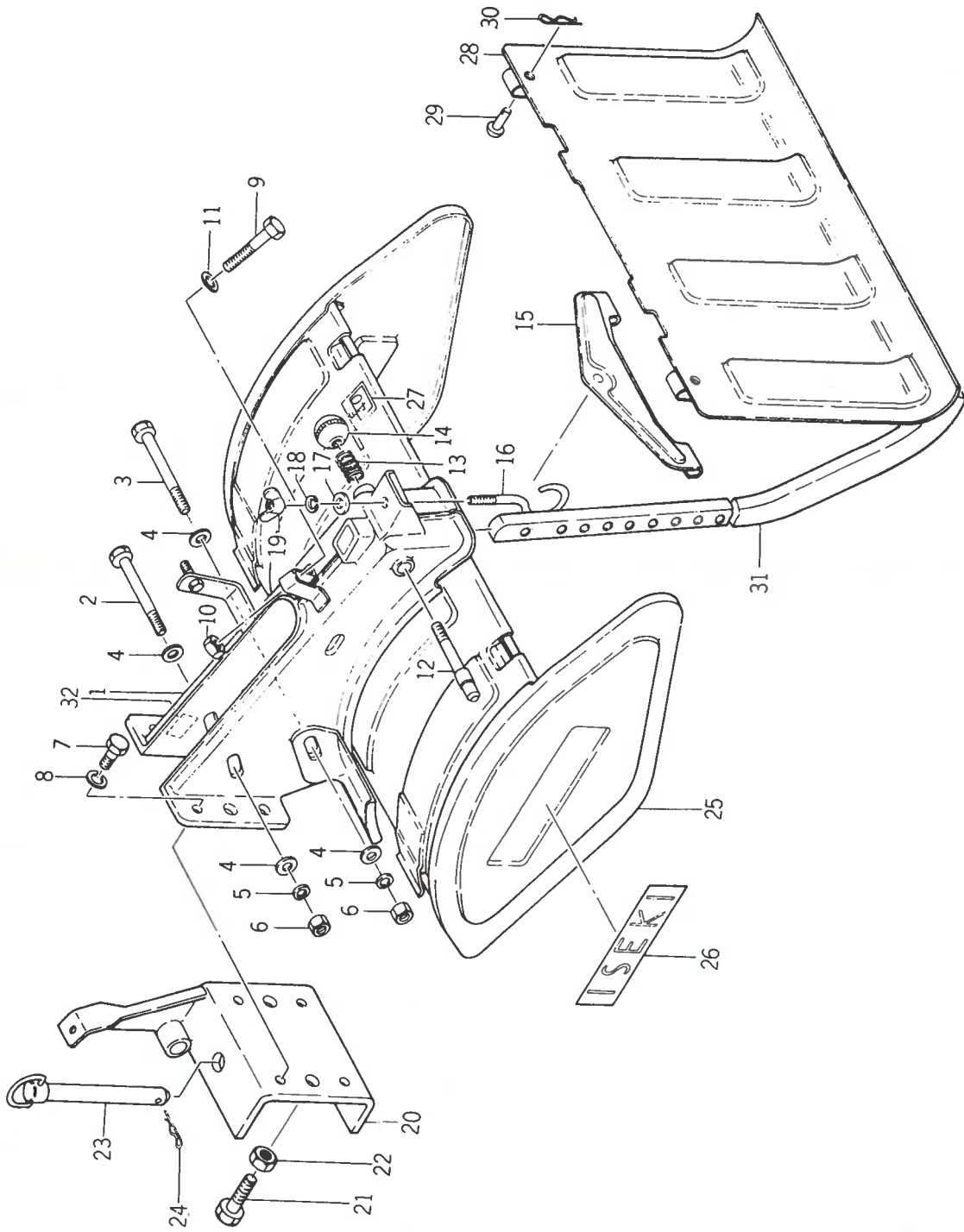




Ref No. Réf N°.	Parts No. Pièces N°.	Description Désignation	Model & Q'ty Modél & Quant	Remarks Remarques
23- 1	1329-241-3000-0	PIPE, WHEEL Tube rallonge	2	★
23- 2	1310-241-0030-0	PIN, HEADED A Goupille	2	★
23- 3	1305-241-0010-0	PIN, HAIR Attache beta	2	★
23- 4	1349-716-1000-0	BOSS, BLADE SET Goupille de hoyau	2	★
23- 5	1305-202-0060-0	PIN, HEADED Goupille	2	★
23- 6	1305-241-0010-0	PIN, HAIR Attache beta	2	★
23- 7	1349-716-0010-0	BLADE LH/C118 Hoyau G.	4	★
23- 8	1349-716-0020-0	BLADE RH/C118 Hoyau D.	4	★
23- 9	V20136-080250	BOLT/M8×25 7T Vis	8	★
23-10	V40116-000800	WASHER, SP/M8 Rondelle	8	★
23-11	V30026-000800	NUT/M8 Erou	8	★

Fig. 24

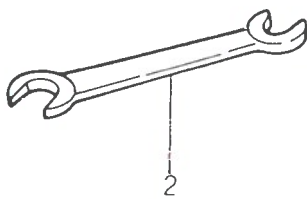
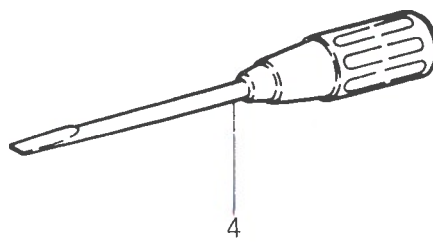
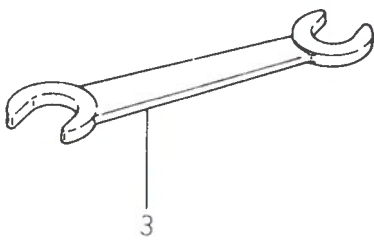
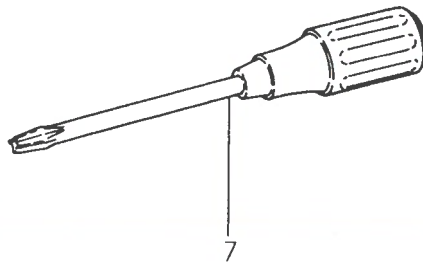
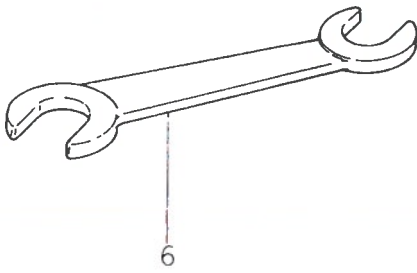
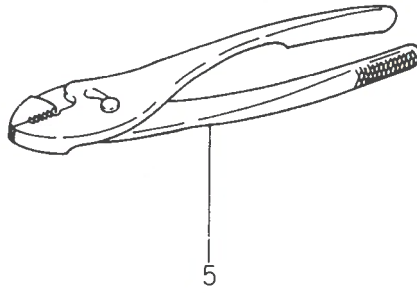
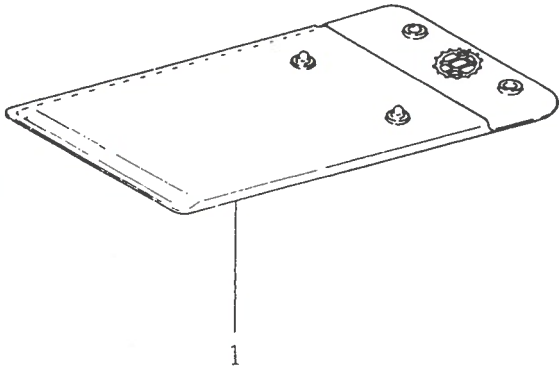
ROTARY FRAME  
Enveloppe de rotobineuses



Ref No. Réf N°.	Parts No. Pièces N°.	Description Désignation	Model & Q'ty Modél & Quant	Remarks Remarques
24- 1	1349-721-1000-0	FRAME, ROTARY Chassis	1	★
24- 2	V20126-100900	BOLT/M10×90 Vis	2	★
24- 3	V20126-100950	BOLT/M10×95 Vis	1	★
24- 4	V41316-001000	WASHER, PL/M10 Rondelle	6	★
24- 5	V40116-001000	WASHER, SP/M10 Rondelle frein	3	★
24- 6	V30026-001000	NUT/M10 Ecrou	3	★
24- 7	V20126-100250	BOLT/M10×25 Vis	4	★
24- 8	V40116-001000	WASHER, SP/M10 Rondelle frein	4	★
24- 9	1349-721-0030-0	BOLT/M10×71 S=40 Vis	1	★
24-10	V30226-001000	NUT/M10 Ecrou	1	★
24-11	1337-721-0020-0	WASHER/11×24×3 Rondelle	1	★
24-12	1349-721-0010-0	PIN, ADJ Tenon	1	★
24-13	1350-311-0030-0	SPRING, PRESS/38 Ressort	1	★
24-14	1407-117-0031-0	KNOB, LEVER/31 Pommeau	1	★
24-15	1349-721-3000-0	HANGER, COVER Support	1	★
24-16	1349-721-0020-0	HOOK Crochet	1	★
24-17	V41316-000800	WASHER, PL/M8 Rondelle	1	★
24-18	V40116-000800	WASHER, SP/M8 Rondelle frein	1	★
24-19	V37016-000600	NUT, WING/M8 Ecrou a oreilles	1	★
24-20	1349-722-1000-0	HITCH, ROTARY Attelage	1	★
24-21	V20026-120450	BOLT/M12×45 Vis	2	★
24-22	V30226-001200	NUT/M12 Ecrou	2	★
24-23	1349-721-3100-0	PIN Attache beta	1	★
24-24	1305-931-0030-0	PIN, HAIR Attache beta	1	★
24-25	1349-723-1000-0	COVER, ROTARY/40 Bavolet	1	★
24-26	1326-953-0070-0	MARK, ISEKI Etiquette	2	★
24-27	1349-956-0010-0	MARK, MODEL Etiquette	1	★
24-28	1349-723-2000-0	GUARD, MUD/40 Bavette	1	★
24-29	1349-723-0010-0	PIN/8×26 Axe	2	★
24-30	1305-241-0010-0	PIN, HAIR Attache beta	2	★
24-31	1349-726-0010-0	SKID, CENTER Barre de profondeur	1	★
24-32	1349-956-0060-0	MARK, ROTARY OIL Re.pere	1	★

Fig. 25

TOOLS  
Outils



Ref No. Réf N°.	Parts No. Pièces N°.	Description Désignation	Model & Q'ty Model & Quant	Remarks Remarques
25- 1	1329-906-0011-0	BAG, TOOL Pochette	1	
25- 2	V92055-080100	SPANNER/8-10 Cle plate	1	
25- 3	V92055-120140	SPANNER/12-14 Cle plate	1	
25- 4	V94019-061000	SCREWDRIVER Tournevis	1	
25- 5	V93625-001500	PLIERS/150 Pincés	1	
25- 6	V92055-130170	SPANNER/13-17 Cle plate	1	
25- 7	V94519-061000	SCREWDRIVER, CROSS Tournevis	1	



## NUMERICAL INDEX

Classées d'après leur de code

**ENGINE**

Parts Code Pièces No.	Ref No. Réf No.	Parts Code Pièces No.	Ref No. Réf No.	Parts Code Pièces No.	Ref No. Réf No.
5110-B06-08XX-X	4-12	5126-515-1220-0	3-13	5211-B05-14AX-X	6-17
5110-B06-12XX-X	3-5	5126-515-1230-0	3-12	5211-B05-25AX-X	4-5
5110-B06-16XX-X	2-24	5126-515-2110-0	3-16	5312-B06-00XX-X	5-5
5110-B06-16XX-X	3-26	5126-515-2310-0	3-20	5211-B06-10XX-X	3-9
5111-203-1220-0	2-7	5126-515-2320-0	3-21	5211-B06-10XX-X	3-24
5111-208-4120-0	6-19	5126-515-3100-0	3-29	5211-B06-10XX-X	6-21
5112-200-9720-0	7-2	5126-515-3140-0	3-30	5211-B06-25XX-X	3-34
5113-906-1210-0	5-7	5126-515-3170-0	3-28	5310-B06-00XX-X	3-19
5115-098-4190-2	6-19b	5126-515-3350-0	3-22	5310-B06-00XX-X	4-14
5121-213-0100-0	2-5	5126-516-1000-0	5-6	5312-B06-00XX-X	3-25
5122-000-9410-0	7-1	5126-516-1810-0	5-2	5315-G10-00XX-X	6-23
5122-005-1240-2	3-11	5126-518-1100-0	6-0-1	5315-G10-00XX-X	2-15
5122-005-3190-0	3-27	5126-518-1110-0	6-1	5410-B06-00XX-X	3-3
5122-005-3830-0	3-32	5126-518-1200-0	6-2	5410-B06-00XX-X	3-7
5122-005-3830-0	2-22	5126-518-1230-0	6-3	5410-B06-00XX-X	3-17
5122-008-4100-0	6-18	5126-518-1280-0	6-8	5410-B05-00XX-X	4-6
5123-013-1210-0	2-6	5126-518-1410-0	6-14	5410-B06-00XX-X	4-10
5123-013-2320-0	2-9a	5126-518-4360-0	6-6	5410-B06-00XX-X	5-3
5123-013-2330-0	2-9-1a	5126-518-4390-0	6-5	5410-B05-00XX-X	6-15
5123-013-2340-0	2-9-2a	5126-518-4400-0	6-4	5461-F04 00XX-X	3-10
5123-014-2110-0	2-8	5126-518-4420-0	6-13	5461-F04-00XX-X	3-14
5123-014-2120-0	2-11	5126-518-4440-0	6-9	5461-F05-00AX-X	4-4
5123-014-2320-0	2-10	5126-518-4480-0	6-10	5461-F05-00AX-X	6-16
5123-026-1860-0	5-1	5126-518-4510-0	6-7	5461-F06-00AX-X	2-23
5123-034-2420-0	2-21	5126-900-8110-0	3-2	5461-F06-00AX-X	3-4
5124-011-4430-0	4-7	5126-900-9000-0	7-0-1	5461-F06-00AX-X	3-8
5124-016-1220-0	5-8	5126-901-3100-0	4-0-1	5461-F06-00AX-X	3-18
5124-016-1260-0	5-9	5126-901-3110-0	4-3	5461-F06-00AX-X	3-23
5124-533-5340-0	2-9	5126-901-3120-0	4-2	5461-F06-00AX-X	3-33
5124-533-5350-0	2-9-1	5126-901-3130-0	4-1	5461-F06-00AX-X	4-11
5124-533-5360-0	2-9-2	5126-901-6110-2	3-1a	5461-F06-00AX-X	4-13
5126-511-4100-0	4-8	5126-901-6320-0	3-6a	5461-F06-00AX-X	5-4
5126-511-4310-0	4-9	5126-931-6710-0	3-35	5461-F06-00AX-X	6-20
5126-511-6110-0	3-1	5126-AA3-020A-X	2-5-1	5461-F10-00AX-X	2-14
5126-511-6320-0	3-6	5126-AA3-030A-X	2-5-2	5461-F10-00AX-X	6-22
5126-513-1110-0	2-4	5126-AA3-131A-X	2-4-1	5510-A32-00XX-X	2-3
5126-513-2100-0	2-1	5126-AA3-132A-X	2-4-2	5511-A05-20XX-X	2-18
5126-513-2100-2	2-1a	5131-220-9420-1	7-1a	5601-A62-02XX-X	2-19
5126-513-3210-0	2-2	5131-228-1390-0	6-12	5601-A62-03XX-X	2-20
5126-513-5200-0	2-17	5131-228-4480-0	6-11		
5126-513-5230-0	2-12	5155-098-4180-2	6-19a		
5126-515-1100-0	2-13	5211-B04-06AX-X	3-15		
5126-515-1210-0	2-16	5211-B05-10AX-X	3-31		

CHASSIS

Parts Code Pièces No.	Ref No. Réf No.	Parts Code Pièces No.	Ref No. Réf No.	Parts Code Pièces No.	Ref No. Réf No.
1317-606-0100-0	14-23	1329-931-0010-0	8-24	1345-121-0110-0	18-4
1323-721-0070-0	20-8	1329-931-0020-0	16-12	1345-121-0120-0	18-14
1323-721-0070-0	20-20	1331-253-1000-0	17-6	1345-121-0121-0	18-14a
1324-957-0120-0	12-25	1331-253-2000-0	17-7	1345-121-0140-0	18-9
1325-401-0090-0	13-5	1331-253-3000-0	17-8	1345-121-0150-0	18-7
1325-401-0090-0	20-16	1331-952-0070-0	12-27	1349-401-0010-0	13-3
1325-601-0050-0	14-8	1331-954-0060-0	12-26	1349-701-0010-0	20-17
1326-706-0020-0	21-11	1337-701-0040-0	20-25	1349-701-0030-0	20-22
1326-953-0070-0	24-26	1337-706-0020-0	21-4	1349-701-3000-0	20-9
1329-200-9020-0	16-0-3	1337-706-0030-0	22-14	1349-706-0010-0	21-3
1329-200-9030-0	16-0-1	1337-706-3000-0	22-1	1349-706-1000-0	21-1
1329-200-9040-0	16-0-2	1337-706-4001-0	22-5	1349-706-2000-0	21-2
1329-201-0030-0	15A-3	1337-706-5001-0	22-8	1349-708-0010-0	21-19
1329-201-0030-0	15-14	1337-706-5002-0	22-8a	1349-709-1000-0	21-26
1329-201-0030-0	19-3	1337-706-5051-0	22-9	1349-716-0010-0	23-7
1329-201-0030-0	20-23	1337-706-5060-0	22-10	1349-716-0020-0	23-8
1329-202-0011-0	20-11	1337-706-6001-0	22-17	1349-716-1000-0	23-4
1329-202-0030-0	20-15	1337-708-0010-0	21-16	1349-721-0010-0	24-12
1329-241-0020-0	16-3	1337-708-0030-0	21-20	1349-721-0020-0	24-16
1329-241-0030-0	16-4	1337-708-0040-0	21-21	1349-721-0030-0	24-9
1329-241-3000-0	17-4	1337-708-0050-0	21-22	1349-721-1000-0	24-1
1329-241-3000-0	23-1	1337-708-0060-0	21-24	1349-721-3000-0	24-15
1329-241-4000-0	17-1	1337-708-0070-0	21-25	1349-721-3100-0	24-23
1329-241-5000-0	17-5	1337-721-0020-0	24-11	1349-722-1000-0	24-20
1329-241-6000-0	16-8	1338-301-4000-0	14-7	1349-723-0010-0	24-29
1301-100-9010-0	9-19	1338-401-0050-0	22-16	1349-723-1000-0	24-25
1301-229-0040-0	11-3	1340-229-0020-0	22-7	1349-723-2000-0	24-28
1305-202-0060-0	23-5	1340-706-0040-0	9-14	1349-726-0010-0	24-31
1305-241-0010-0	17-3	1343-216-0020-0	9-11	1349-956-0010-0	24-27
1305-241-0010-0	23-3	1343-216-0030-0	9-12	1349-956-0060-0	24-32
1305-241-0010-0	23-6	1343-220-0020-0	10-16	1349-956-0080-0	22-18
1305-241-0010-0	24-30	1343-220-0030-0	10-11	1350-101-0010-0	8-3
1305-701-0060-0	15A-2	1343-220-0030-0	10-28	1350-101-0020-0	8-4
1305-701-0060-0	15-15	1343-229-0040-0	11-6	1350-106-0020-0	8-16
1305-701-0060-0	19-2	1344-216-0020-0	9-13	1350-201-1000-0	15A-1
1305-931-0030-0	9-20	1345-121-0020-0	18-1	1350-201-1000-0	15-13
1305-931-0030-0	24-24	1345-121-0030-0	18-6	1350-202-0010-0	15-20
1310-241-0030-0	17-2	1345-121-0040-0	18-11	1350-202-0020-0	15A-11
1310-241-0030-0	23-2	1345-121-0050-0	18-5	1350-202-0020-0	15-25
1315-621-0140-0	13-4	1345-121-0060-0	18-10	1350-202-0030-0	15A-16
1329-906-0011-0	25-1	1345-121-0070-0	18-8	1350-202-0030-0	15-30
1329-917-0020-0	20-24	1345-121-0080-0	18-12	1350-202-1000-0	15-24
1329-902-0030-0	14-2	1345-121-0090-0	18-2	1350-216-0010-0	9-3



Parts Code Pièces No.	Ref No. Réf No.	Parts Code Pièces No.	Ref No. Réf No.	Parts Code Pièces No.	Ref No. Réf No.
1350-216-1001-0	9- 1	1350-403-0010-0	13-12	1353-601-2000-0	14-10
1350-216-2001-0	9- 2	1350-606-0020-0	14-17	1353-602-2000-0	14A- 1
1350-217-0010-0	10- 1	1350-606-0030-0	14-20	1353-602-2100-0	14A- 2
1350-217-0020-0	10- 4	1350-606-0050-0	14-18	1353-602-2200-0	14A- 6
1350-217-0030-0	10- 5	1350-606-0060-0	14-19	1353-606-0010-0	14-24
1350-220-0010-0	10- 7	1350-611-1000-0	15- 3	1353-606-0040-0	14-32
1350-220-0020-0	10- 9	1350-701-0010-0	20- 2	1353-606-0050-0	14-29
1350-220-0040-0	10-10	1350-701-0020-0	20-21	1353-606-0060-0	14-30
1350-220-0040-0	10-16a	1350-701-1000-0	20- 1	1353-606-0070-0	14-31
1350-220-0040-0	10-27	1350-917-0010-0	19- 1	1353-606-1000-0	14-13
1350-220-1000-0	10- 8	1350-930-1000-0	9-15	1353-611-1000-0	15- 1
1350-221-0010-0	10-15	1352-616-0020-0	15A-24	1353-611-2000-0	15- 7
1350-221-0020-0	10-18	1353-100-0520-0	18- 0-1	1353-612-2000-0	15A-17
1350-221-0030-0	10-17	1353-100-0521-0	18- 0-1a	1353-612-2100-0	15A-18
1350-221-0040-0	10-18a	1353-101-1000-0	8- 1	1353-612-2200-0	15A-27
1350-221-1000-0	10-14	1353-101-2000-0	8- 2	1353-612-2300-0	15A-28
1350-221-1001-0	10-14a	1353-106-0010-0	8-13	1353-616-0010-0	8-20
1350-225-1000-0	10-19	1353-106-1000-0	8-12	1353-651-2000-0	13-22
1350-225-1001-0	10-19a	1353-121-0020-0	18- 3	1353-951-0021-0	12- 2
1350-226-0010-0	10-24	1353-121-2000-0	18-18	1353-952-0020-0	15- 2
1350-226-0020-0	10-25	1353-121-2010-0	18-19	1353-952-0020-0	15A-31
1350-226-0030-0	10-26	1353-121-2020-0	18-20	1353-953-0010-0	14A-11
1350-229-0010-0	11- 1	1353-121-2040-0	18-21	1359-621-0020-0	13-21
1350-229-0020-0	11- 2	1353-121-2050-0	18-22	1366-706-0010-0	21-15
1350-229-1000-0	11- 9	1353-121-2060-0	18-23	1372-121-2240-0	18-28
1350-301-0010-0	12- 4	1353-121-2070-0	18-24	1373-121-0010-0	8-28
1350-301-0020-0	12-11	1353-121-2080-0	18-25	1376-402-0030-0	13-11
1350-301-1000-0	12- 1	1353-121-2090-0	18-26	1376-601-0030-0	14A- 9
1350-301-1001-0	12- 1a	1353-121-2110-0	18-27	1378-202-2000-0	15A- 9
1350-301-2000-0	12- 9	1353-121-2120-0	18-29	1379-311-0020-0	12-13
1350-301-3000-0	12-10	1353-151-2100-0	8-27	1379-402-2000-0	13- 8a
1350-311-0020-0	12-18	1353-201-0010-0	15-18a	1407-117-0031-0	12-20
1350-311-0030-0	12-19	1353-201-1000-0	15-18	1407-117-0031-0	24-14
1350-311-0030-0	24-13	1353-205-0010-0	15A- 6	2101-230-0010-0	22-14b
1350-311-0040-0	12-21	1353-206-2000-0	15A- 8	4106-105-3030-0	22-16a
1350-311-1000-0	12-12	1353-217-0020-0	10-31	4114-606-0030-0	12-23
1350-311-1001-0	12-12a	1353-218-0010-0	10- 1-1	8057-006-0000-0	9-21
1350-400-0510-0	13- 1	1353-301-0010-0	12- 4-1	8057-006-0020-0	9-22
1350-400-0520-0	13- 8	1353-402-0010-0	13-10	8057-006-0030-0	9-23
1350-401-0020-0	13- 6	1353-600-0510-0	14-28		
1350-401-0030-0	13- 7	1353-600-0520-0	13-18		
1350-401-0040-0	13- 3a	1352-601-0030-0	14A-10		
1350-401-2000-0	13- 1a	1353-601-1000-0	14- 1		





**KS**

I300-098-0061-0  
Printed in Japan Dec. 1978  
Revision March 1982

**ISEKI & CO., LTD**

**Foreign Affairs Division**

3-6, Kioicho, Chiyoda-ku, Tokyo, 102, Japan

Telex: 232-2752, 232-2753

Cable address: ISEKIRICE TOKYO

Phone: 03-238-5245-5258